

NACIONAL MOTOR, S.A.U. DERBI

C/ Barcelona, nº19 - Martorelles 08107 - BARCELONA (SPAIN)

Tel. 93 565 78 78 - Fax 93 565 78 52

DERBI



SENDA R X-TREM 2007 E2

CÓDIGO CATÁLOGO
CATALOGUE NUMBER

7077CH07004

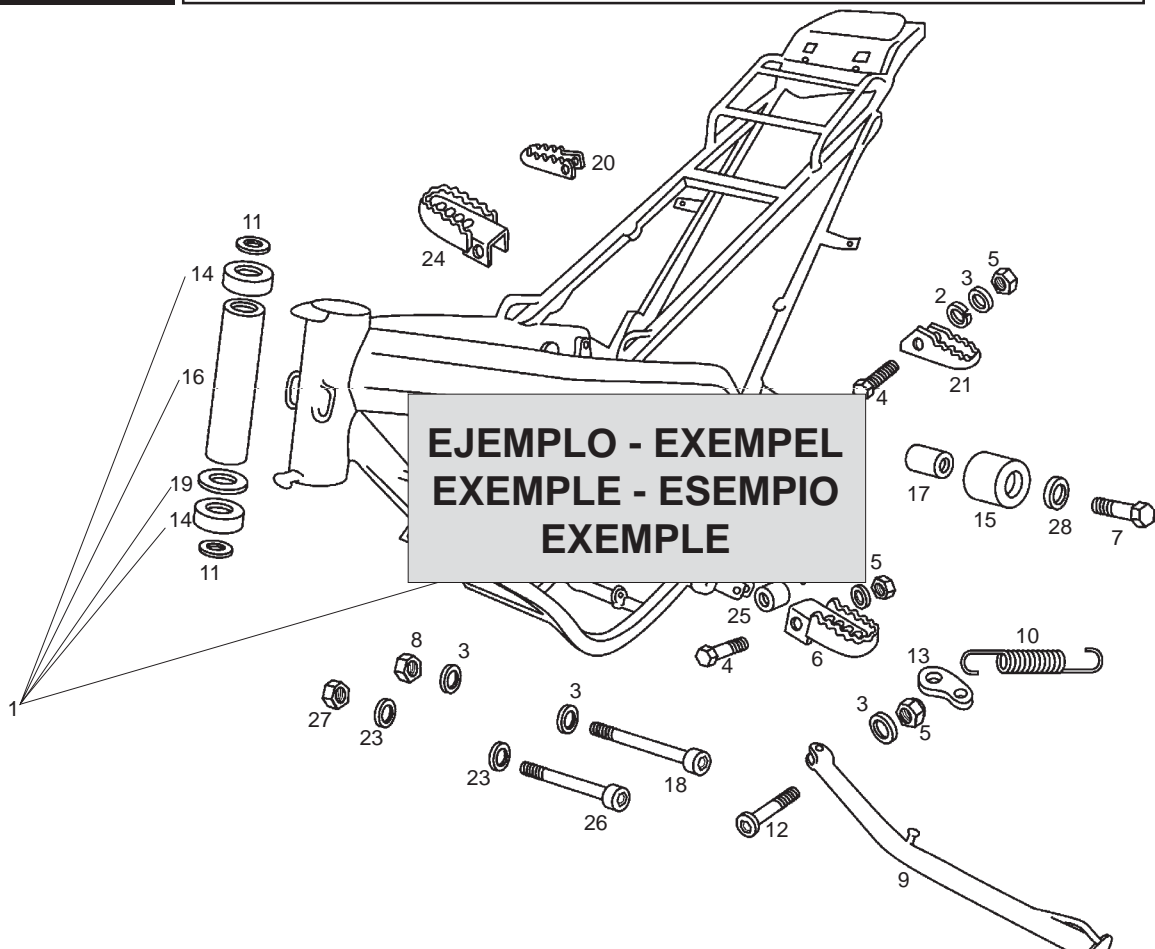

Fig.	Ver.	COD. KOD.	DESCRIPCIÓN DENOMINAZIONE NAME	BEZEICHUNG DESIGNATION	MOD.	NOTAS NOTES MITSCHRIFT NOTES
01A		00G01924601	R-SCTO.CUADRO C/COJIN. ATLANTIS TELAIO FRAME SUB-ASSEMBLY	RHAMEN CADRE COMPLET	12	XXXXXXX
②	01	00G01924601	R-SCTO.CUADRO C/COJIN. ATLANTIS TELAIO FRAME SUB-ASSEMBLY	RHAMEN CADRE COMPLET	12	XXXXXXX
③	02	00G01924601	R-SCTO.CUADRO C/COJIN. ATLANTIS TELAIO FRAME SUB-ASSEMBLY	RHAMEN CADRE COMPLET	12	XXXXXXX
④	03	00G01924601	R-SCTO.CUADRO C/COJIN. ATLANTIS TELAIO FRAME SUB-ASSEMBLY	RHAMEN CADRE COMPLET	12	XXXXXXX

1- Código de localización de piezas. 2- Código indicativo de pieza reemplazada. 3- Código indicativo de pieza anulada. 4- Código indicativo de pieza restituída (esta se monta de nuevo). 5- Código de referencia de la pieza. 6- Identificación de modelos. 7- Los códigos de esta casilla indican que, a partir del número de chasis o motor indicado dentro de esta, se monta una nueva pieza que reemplaza a la anterior (sección 2), que una pieza no se monta (sección 3), o que la pieza anulada se monta de nuevo (sección 4), y concierne a los modelos indicados (sección 6). 8- Denominación de la pieza.

1- Codice di localizzazione pezzi. 2- Codice indicatore del pezzo sostituito. 3- Il pezzo precedente non si monta. 4- Codice indicatore dei pezzi che si tornano a montare. 5- Codice di identificazione del pezzo. 6- Identificazione del modello. 7- Il codice di questa casella indica che, dal numero di Telaio/motore indicato, si monta un nuovo pezzo che sostituisce il precedente (sezione 2), che un pezzo non si monta (sezione 3), oppure che il pezzo annullato si monta di nuovo (sezione 4), facendo riferimento al modello indicato (sezione 6). 8- Denominazione del pezzo.

1- Part location number. 2- Substituted part number. 3- Withdrawn part number (no longer fitted). 4- Restored part number (newly fitted going withdrawn). 5- Part reference number. 6- Model identification number. 7- Chassis or engine number from which a new part is fitted substituting a part which has been withdrawn (see para 2) or a part is withdrawn is fitted again (see para 4), in the models indicated (see para 6). 8- Part identification label.

1- Zeichungs - Number. 2- Ausführung. 3- Gestrichene Ersatzteilnummer. 4- Ersetzte Ersatzteilnummer. 5- Ersatzteilnummer. 6- Modell - Nummer. 7- Rhamen - order motonummer, für die ein neues teil eingsetzt wird, z.b. eine nummer, die geändert (s. para 2), order ein teil, das gestrichen wurde (s. para 3), order ein teil, das vorübergehend verschiedene modelle (s. para 6) 8- Bezeichnung.

1- Code de localisation de la pièce. 2- Code indicateur de pièce remplace par un autre. 3- Code indicateur de pièce annulé (elle n'est plus montée). 4- Code indicateur de pièce restituée (elle se monte à nouveau). 5- Code référence de la pièce. 6- Les codes de cette case indiquant qu'à partir de numero 7- Chassis ou de moteur indiqué, un nouvelle pièce est montée en remplacement d'une autre (section 2), qu'une pièce n'est plus montée (section 3) ou la pièce anulée est montée à nouveau (section 4) et concernant les modélès indiqués (section 6). 8- Denomination de la pièce.

**IDENTIFICACION DE MODELOS REPRESENTADOS EN ESTE
CATALOGO SEGUN LOS DIGITOS SIGUIENTES**

**IDENTIFICAZIONE DEI MODELLI RAPPRESENTATI IN QUESTO CATALOGO
SECONDO I NUMERI A SEGUIRE**

**THE MODELS REFERRED INTO THIS CATALOGUE ARE IDENTIFIED
BY FOLLOWING NUMBERS**

BESTIMMUNG DER VERSCHIEDENEN MODELLE IN DIESEM KATALOG

**IDENTIFICATION DES MODELOES REPRESENTES DANS CE CATALOGUE,
EN FONCTION DES CODES SUIVANTS**

MODELO MODELLI MODEL MODELL MODELE	DENOMINACION DENOMINAZIONE MODEL NAME BEZEICHNUNG DENOMINATION	CODIGO MODELO CODICE MODELLI CODE MODEL KODE MODELL CODE MODELE
1	SENDA R X-TREM ESPAÑA AZUL (JACINTO) 2007 E2 SENDA R X-TREM FRANCE BLUE (JACINTO) 2007 E2 SENDA R X-TREM ENGLAND BLUE (JACINTO) 2007 E2 SENDA R X-TREM ITALY BLUE (JACINTO) 2007 E2	E92H5 1E740 E92H5 1F740 E92H5 1G740 E92H5 1I740
2	SENDA R X-TREM AUSTRIA BLUE (JACINTO) 2007 E2 SENDA R X-TREM BENELUX BLUE (JACINTO) 2007 E2 SENDA R X-TREM DENMARK BLUE (JACINTO) 2007 E2 30KM/H	E92H5 1U740 E92H5 1X740 E92H5 1D740
3	SENDA R X-TREM SCANDINAVIA BLUE (JACINTO) 2007 E2	E92H5 1V740
4	SENDA R X-TREM ESPAÑA NEGRO (OMBU) 2007 E2 SENDA R X-TREM FRANCE BLACK (OMBU) 2007 E2 SENDA R X-TREM ENGLAND BLACK (OMBU) 2007 E2 SENDA R X-TREM ITALY BLACK (OMBU) 2007 E2	E92H5 1E780 E92H5 1F780 E92H5 1G780 E92H5 1I780
5	SENDA R X-TREM AUSTRIA BLACK (OMBU) 2007 E2 SENDA R X-TREM BENELUX BLACK (OMBU) 2007 E2 SENDA R X-TREM DENMARK BLACK (OMBU) 2007 E2 30KM/H	E92H5 1U780 E92H5 1X780 E92H5 1D780
6	SENDA R X-TREM SCANDINAVIA BLACK (OMBU) 2007 E2	E92H5 1V780
7	SENDA R X-TREM ESPAÑA BLANCO (CYCLAMEN) 2007 E2 SENDA R X-TREM FRANCE WHITE (CYCLAMEN) 2007 E2 SENDA R X-TREM ENGLAND WHITE (CYCLAMEN) 2007 E2 SENDA R X-TREM ITALY WHITE (CYCLAMEN) 2007 E2	E92H5 1E710 E92H5 1F710 E92H5 1G710 E92H5 1I710
8	SENDA R X-TREM AUSTRIA WHITE (CYCLAMEN) 2007 E2 SENDA R X-TREM BENELUX WHITE (CYCLAMEN) 2007 E2 SENDA R X-TREM DENMARK WHITE (CYCLAMEN) 2007 E2 30KM/H	E92H5 1U710 E92H5 1X710 E92H5 1D710
9	SENDA R X-TREM SCANDINAVIA WHITE (CYCLAMEN) 2007 E2	E92H5 1V710











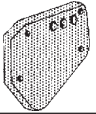
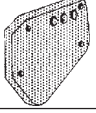
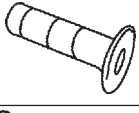

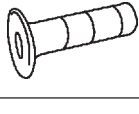
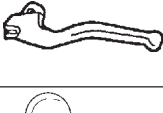
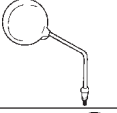
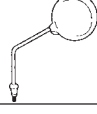











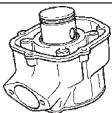

IMAGEN FIGURE	LAMINA DIAGRAM	POSICION POSITION	CODIGO CODE	DESCRIPCION ESPAÑOL / SPANISH DESCRIPTION DESCRIPCION INGLES / ENGLISH DESCRIPTION	CANTIDAD POR MOTO QTY PER BIKE	NOTES NOTES
	04	26A	00H03209251	ESPUMA FILTRO AIRE AIR FILTER FOAM	1	
	04	26B	00H03201251	ESPUMA FILTRO AIRE AIR FILTER FOAM	1	ONLY SCANDINAVIA
	06	04A	00H00930091	EMPUÑADURA LADO GAS GRIP, THROTTLE SIDE	1	
	06	06A	00F00902291	MANETA FRENO DELANTERO FRONT BRAKE LEVER	1	
	06	15A	00H00930071	EMPUÑADURA LADO EMBRAGUE GRIP, CLUTCH SIDE	1	
	06	16A	00F00910291	MANETA EMBRAGUE CLUTCH LEVER	1	
	06	19A	00H02213671	ESPEJO RETROVISOR DERECHO RIGHT MIRROR	1	
	06	20A	00H04608921	ESPEJO RETROVISOR IZQUIERDO LEFT MIRROR	1	
	07	07A	00H01000131	LAMPARA FARO DELANTERO 12V 35W/35W HEADLIGHT BULB	1	
	07	10A	00H01000371	LAMPARA PILOTO TRASERO 12V 21/5W BULB, TAILLIGHT/STOP	1	
	07	23A	0000A517011	BOMBILLA INTERMITENTES INDICATOR LIGHT BULB	4	
	08	07A	00H01209021	DISCO FRENO DELANTERO FRONT BRAKE DISC	1	
	08	20A	00G04700141	JUEGO PASTILLAS DE FRENO DELANTERO SET OF BRAKE PADS, FRONT	1	
	09	07A	00H01502201	CADENA SECUNDARIA 130 P TRANSMISSION CHAIN 130 S	1	
	09	07B	00H01506201	CADENA SECUNDARIA 136 P TRANSMISSION CHAIN 136 S	1	ONLY SCANDINAVIA
	09	15A	00H01317032	PLATO ARRASTRE Z-53 DRIVE PLATE Z-53	1	

IMAGEN FIGURE	LAMINA DIAGRAM	POSICION POSITION	CODIGO CODE	DESCRIPCION ESPAÑOL / SPANISH DESCRIPTION DESCRIPCION INGLES / ENGLISH DESCRIPTION	CANTIDAD POR MOTO QTY PER BIKE	NOTES NOTES
	09	15B	00H01326031	PLATO ARRASTRE Z-65 DRIVE PLATE Z-65	1	ONLY SCANDINAVIA
	09	16A	00H01305531	DISCO FRENO TRASERO REAR BRAKE DISC	1	
	10	16A	00H01120021	PALANCA FRENO TRASERO REAR BRAKE LEVER	1	
	10	23A	00G04700141	JUEGO PASTILLAS DE FRENO TRASERO SET OF BRAKE PADS, REAR	1	
	11	11A	00H01801411	LLAVE CONTACTO POR MECANIZAR BLANK KEY	1	
	15	01A	847508	CTO CILINDRO PISTON CYLINDER PISTON ASSY	1	
	15	02A	8472625001	CTO. PISTON (A) PISTON (A)	1	
	15	02B	8472625002	CTO. PISTON (B) PISTON (B)	1	
	15	02C	8472625003	CTO. PISTON (C) PISTON (C)	1	
	15	02D	8472625004	CTO. PISTON (D) PISTON (D)	1	
	15	03A	847006	ARO PISTON PISTON RING	2	
	16	07A	847043	DISCO CONDUcido DRIVEN CLUTCH PLATE	3	
	16	08A	847044	DISCO CONDUCTOR DRIVE CLUTCH PLATE	4	
	17	02A	00H02703421	PALANCA CAMBIO GEARSHIFT LEVER	1	
	18	22A	00H02813371	PIÑON SALIDA CAMBIO Z-11 OUTPUT PINION Z-11	1	
	18	22B	00H02808371	PIÑON SALIDA CAMBIO Z-12 OUTPUT PINION Z-12	1	ONLY SCANDINAVIA

LAMINA / STAMPA / DIAGRAM / BILD / FEUILLE - 1



LAMINA / STAMPA / DIAGRAM / BILD / FEUILLE - 2

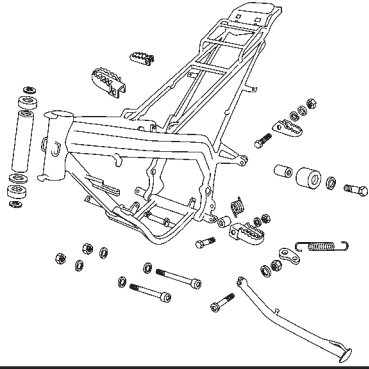
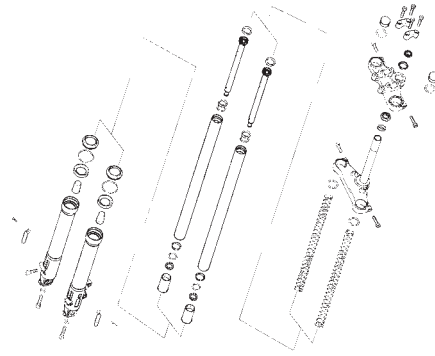

LAMINA / STAMPA / DIAGRAM / BILD / FEUILLE - 3

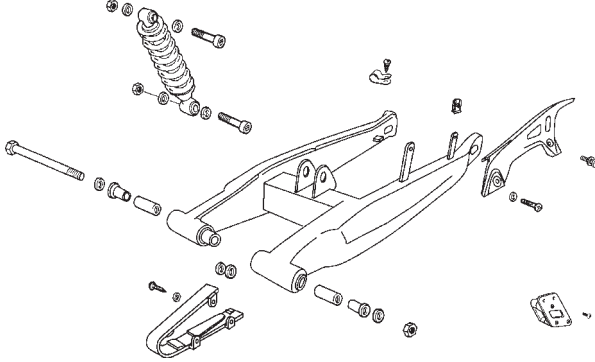

LAMINA / STAMPA / DIAGRAM / BILD / FEUILLE - 4

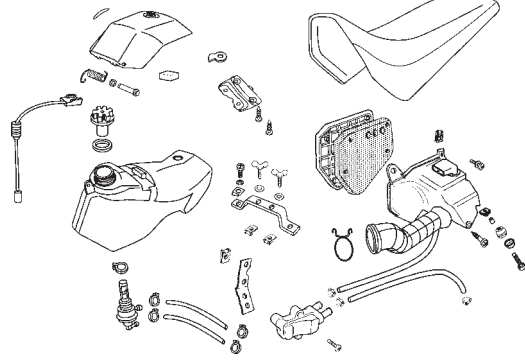

LAMINA / STAMPA / DIAGRAM / BILD / FEUILLE - 5

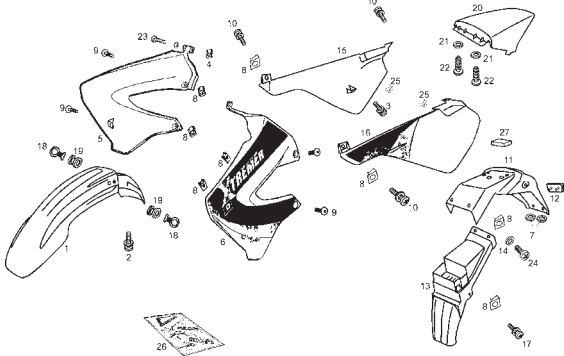

LAMINA / STAMPA / DIAGRAM / BILD / FEUILLE - 6

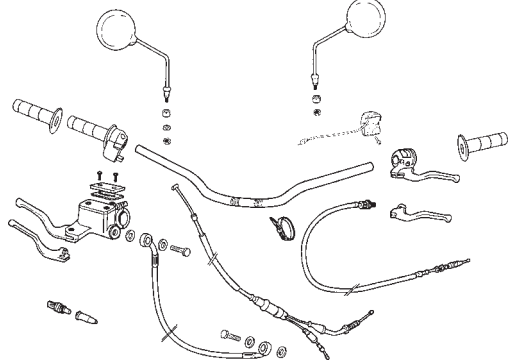

LAMINA / STAMPA / DIAGRAM / BILD / FEUILLE - 7



LAMINA / STAMPA / DIAGRAM / BILD / FEUILLE - 8

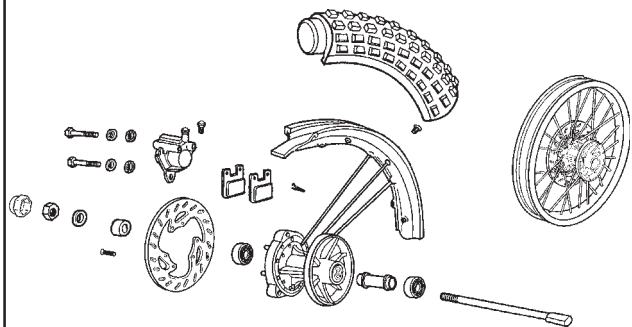

LAMINA / STAMPA / DIAGRAM / BILD / FEUILLE - 9

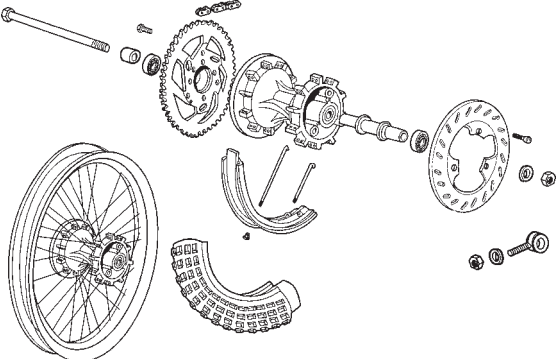

LAMINA / STAMPA / DIAGRAM / BILD / FEUILLE - 10

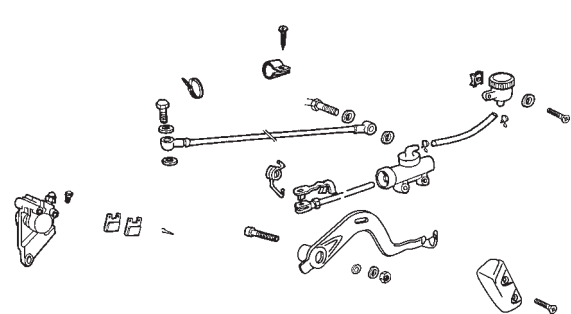

LAMINA / STAMPA / DIAGRAM / BILD / FEUILLE - 11

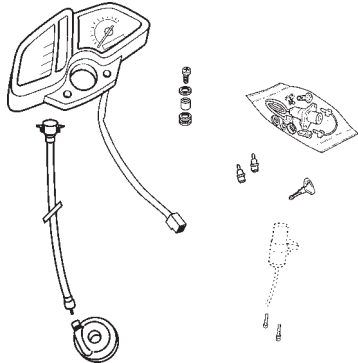

LAMINA / STAMPA / DIAGRAM / BILD / FEUILLE - 12

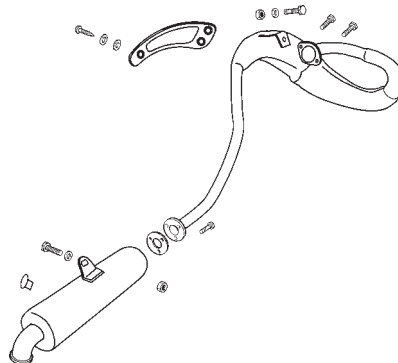

LAMINA / STAMPA / DIAGRAM / BILD / FEUILLE - 13A

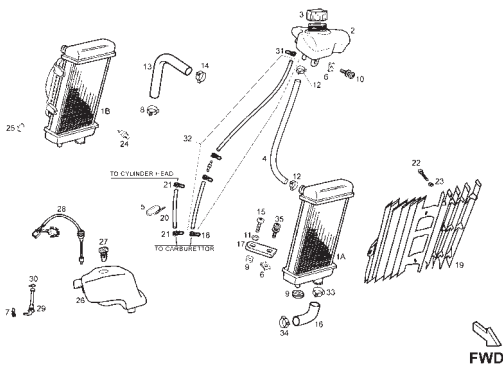

LAMINA / STAMPA / DIAGRAM / BILD / FEUILLE - 13B

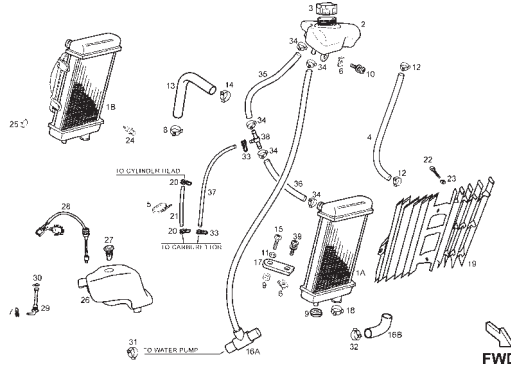

LAMINA / STAMPA / DIAGRAM / BILD / FEUILLE - 14

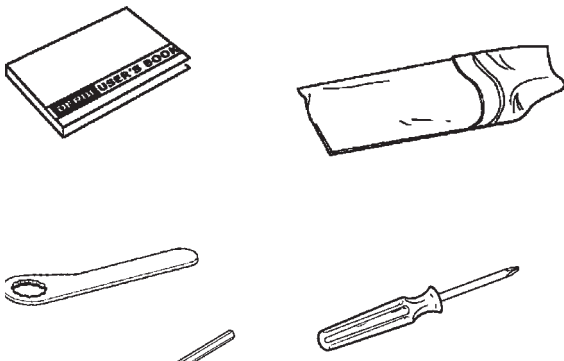

LAMINA / STAMPA / DIAGRAM / BILD / FEUILLE - 15

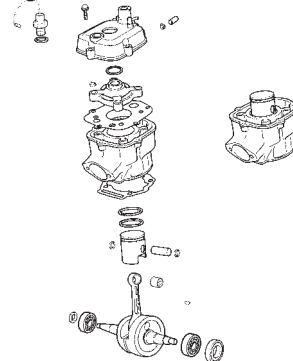

LAMINA / STAMPA / DIAGRAM / BILD / FEUILLE - 16

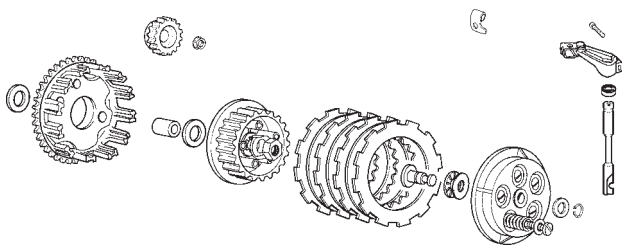

LAMINA / STAMPA / DIAGRAM / BILD / FEUILLE - 17

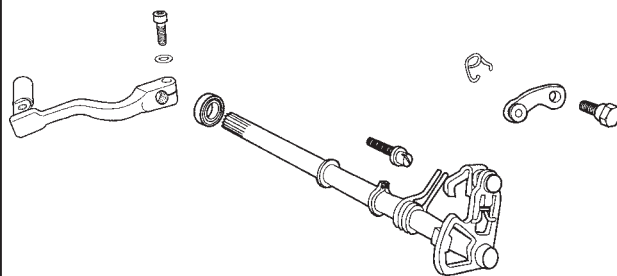

LAMINA / STAMPA / DIAGRAM / BILD / FEUILLE - 18

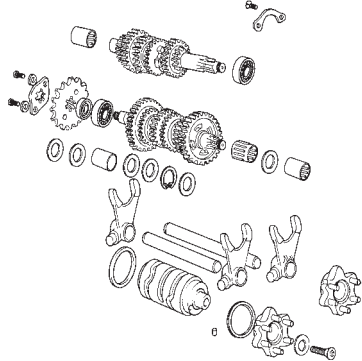

LAMINA / STAMPA / DIAGRAM / BILD / FEUILLE - 19

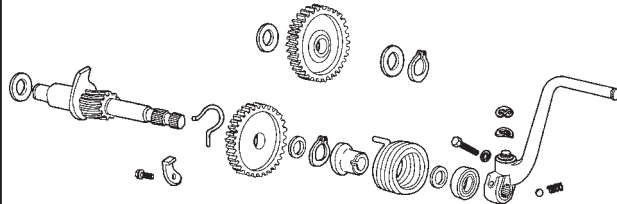

LAMINA / STAMPA / DIAGRAM / BILD / FEUILLE - 20

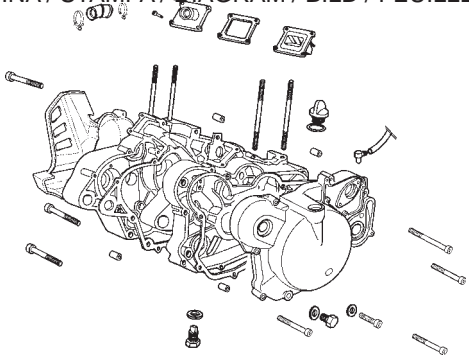

LAMINA / STAMPA / DIAGRAM / BILD / FEUILLE - 21

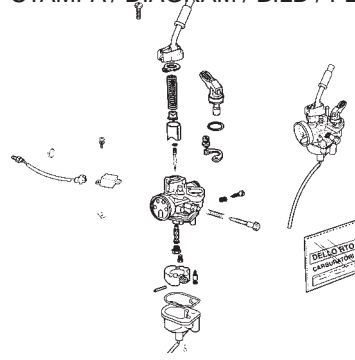

LAMINA / STAMPA / DIAGRAM / BILD / FEUILLE - 22

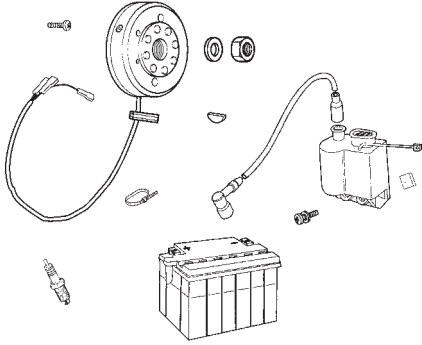

LAMINA / STAMPA / DIAGRAM / BILD / FEUILLE - 23

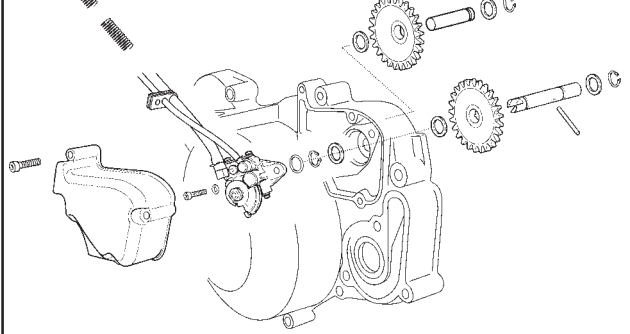

LAMINA / STAMPA / DIAGRAM / BILD / FEUILLE - 24

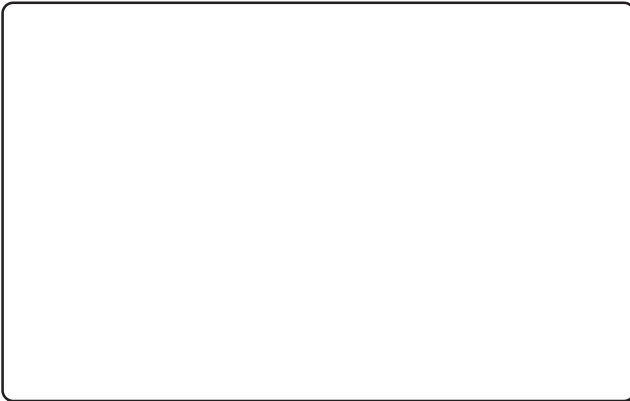
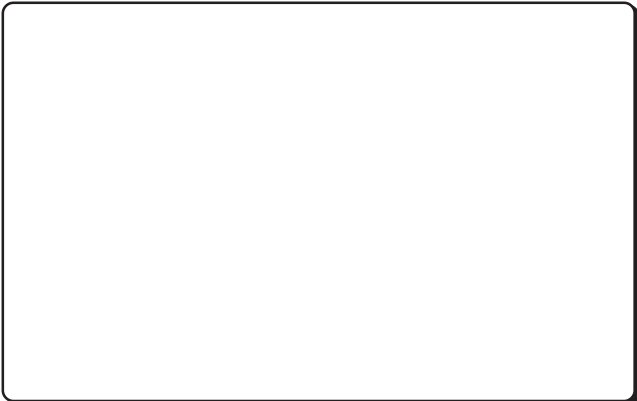
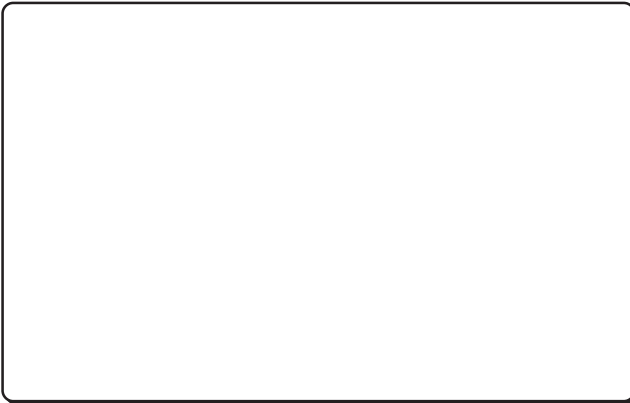
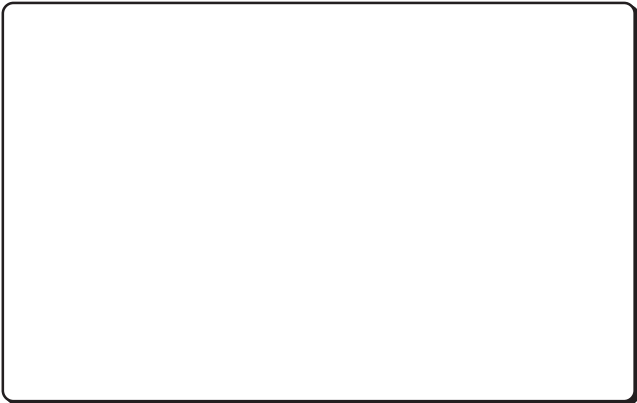
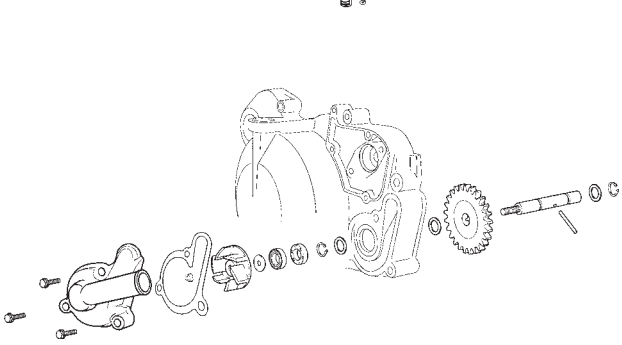

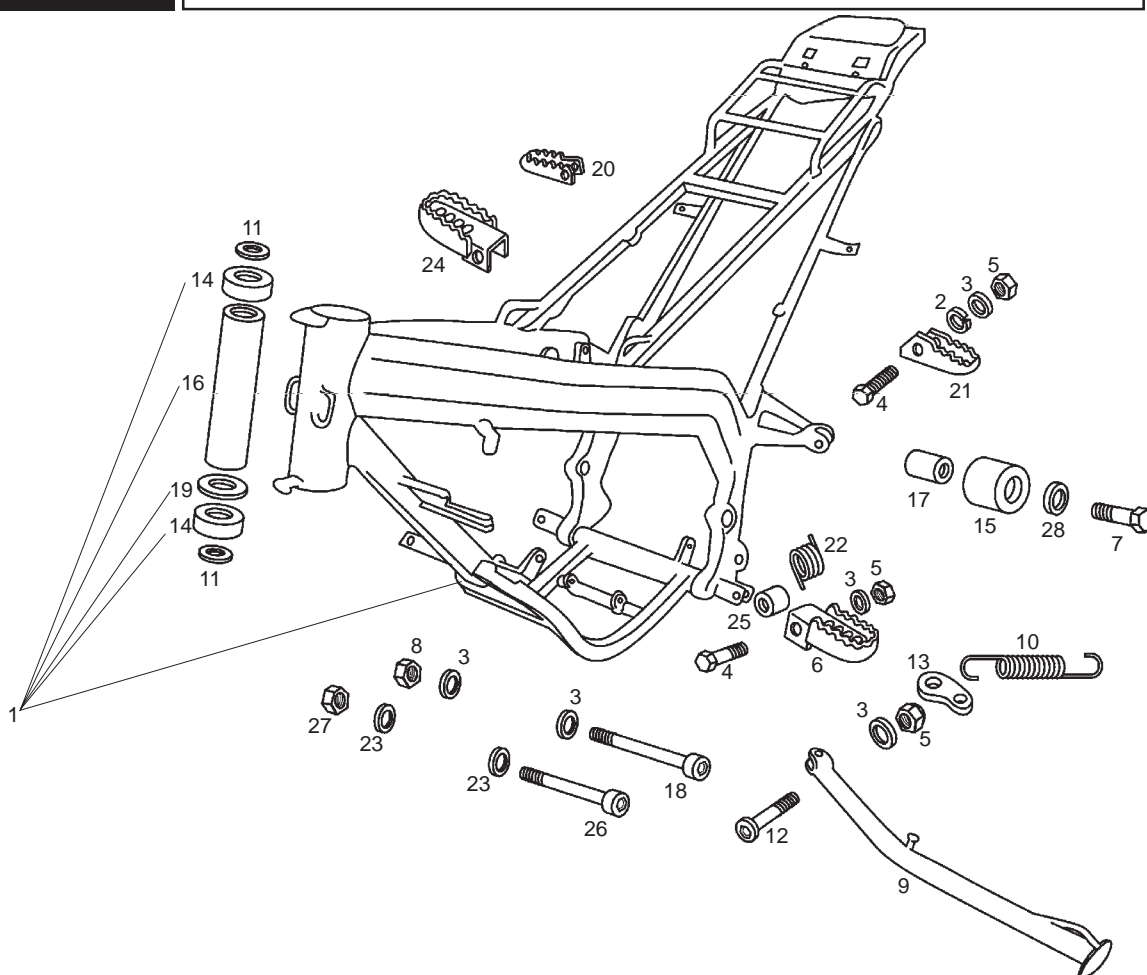

Fig.	Ver.	COD. KOD.	DESCRIPCIÓN DENOMINAZIONE NAME	BEZEICHUNG DESIGNATION	MOD.	NOTAS NOTES NOTA MITSCHRIFT NOTES
01A		00H01961602	R-CTO CUADRO CON RODAMIENTOS TELAIO FRAME	RAHMEN SOUS ENSEMBLE CADRE	1 2 3 4 5 6 7 8 9	
02A		00036008000	ARANDELA MUELLE RONDELLA WASHER	SCHEIBE RONDELLE	1 2 3 4 5 6 7 8 9	
03A		00402080001	ARANDELA D8 RONDELLA WASHER	SCHEIBE RONDELLE	1 2 3 4 5 6 7 8 9	
04A		00022084021	TORNILLO C/EXAG. 8M125X40 VITE SCREW	SCHRAUBE VIS	1 2 3 4 5 6 7 8 9	
05A		00023108000	TUERCA AUTOBLOCANTE 8M125 DADO NUT	MUTTER ECROU	1 2 3 4 5 6 7 8 9	
06A		00H02201312	SCTO.ESTRIBERA IZQUIERDA PILOTO APPOG. SIN. LEFT FOOTREST	FUSSRASTER LINKS REPOSE PIED GAUCHE	1 2 3 4 5 6 7 8 9	
07A		00022084521	TORNILLO C/EXAG. 8M125X45 VITE SCREW	SCHRAUBE VIS	1 2 3 4 5 6 7 8 9	
08A		00262080022	TUERCA AUTOBLOCANTE 8M125 DADO NUT	MUTTER ECROU	1 2 3 4 5 6 7 8 9	
09A		00H00819012	SCTO. PATA CABALLETE ZAMPA CAVALETTA SIDE STAN SUB-ASSY	SEITENSTANDER BEQUILLE LATERALE	1 2 3 4 5 6 7 8 9	
10A		00H00804081	MUELLE PATA CABALLETE MOLLA ZAMPA CAVALLETTO SIDE STAND SPRING	FEDER GESTELLFUSS AUSSEN RESSORT DE BEQUILLE	1 2 3 4 5 6 7 8 9	
11A		00008902630	ARANDELA TAPON TUBO PIERNA RONDELLA WASHER	SCHEIBE RONDELLE	1 2 3 4 5 6 7 8 9	

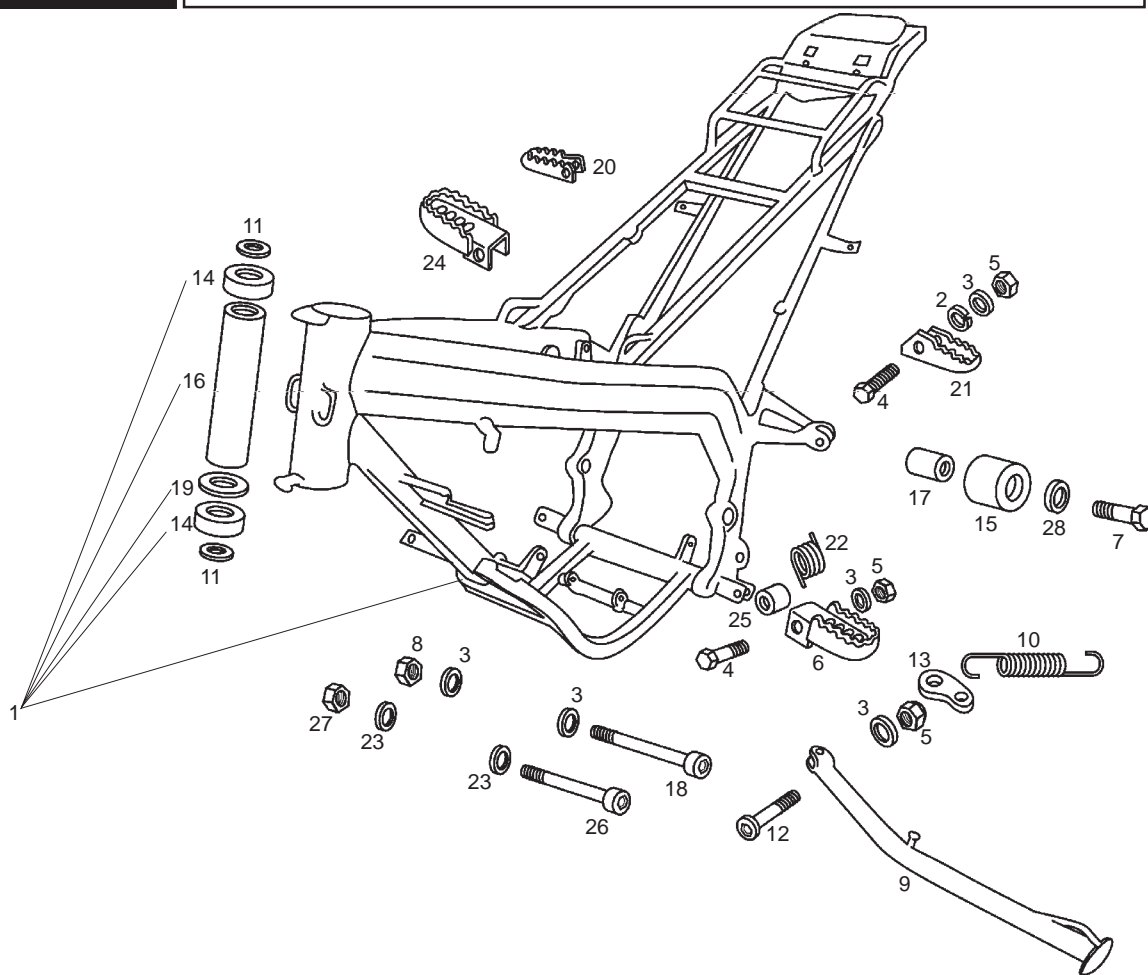

Fig.	Ver.	COD. KOD.	DESCRIPCIÓN DENOMINAZIONE NAME	BEZEICHNUNG DESIGNATION	MOD.	NOTAS NOTES NOTA MITSCHRIFT NOTES
12A		00H00805072	TORNILLO FIJ. PATA CABALLETE VITE SCREW	SCHRAUBE VIS	1 2 3 4 5 6 7 8 9	
13A		00H00800422	PLACA RETORNO CABALLETE PIASTRINA RITORNO CAVALLETTO G SPRING KIK-STAND SUPPORT	PLATTE F. GESTELLRUCKFUHRU SUPPORT RESSORT DE BEQUILLE	1 2 3 4 5 6 7 8 9	
14A		00000056205	COJINETE CUSCINETTO BEARING	LAGER COUSSINET	1 2 3 4 5 6 7 8 9	
15A		00H01801771	RODILLO TENSOR CADENA RULLO TENSORE CATENA CHAIN SUPPORTY GUIDE	ROLLE ROULETTE GUIDE CHAINE	1 2 3 4 5 6 7 8 9	
16A		00H06301401	TUBO SEPARADOR RDMTO.DIRECC. TUBO SEPARAZIONE CUSCINETTO ST STEERING BEARING SEPARATOR TUB	DISTANZROHR LENKUNGLAGER TUBE SEPARATION ROULEMENT	1 2 3 4 5 6 7 8 9	
17A		00002518790	CASQUILLO GUIA CADENA GHIERA SOCKET CHAIN GUIDE	DISTANZ ENTRETOISE GUIDE CHAINE	1 2 3 4 5 6 7 8 9	
18A		00H02500272	TORNILLO FIJ.INF.MOTOR ALL.8M125X90 VITE SCREW	SCHRAUBE VIS	1 2 3 4 5 6 7 8 9	
19A		00H06500451	ARANDELA COJIN.TUBO DIRECCION RONDELLA BRONZINA TUBO STERZO STEERING TUBE BEARING WASHER G	STEERING TUBE BEARING WASHER G RONDELLE COUSSINET TUBE DIRECT	1 2 3 4 5 6 7 8 9	
20A		00D01520096	ESTRIBERA DERECHA PASAJERO PEDANA DESTRA RIGHT FOOT REST	FUSSRASTER RECHTS REPOSE-PIED DROIT	1 2 3 4 5 6 7 8 9	
21A		00D01540456	ESTRIBERA IZQUIERDA PASAJERO PEDANA SINISTRA LEFT FOOT REST	FUSSRASTER LINKS REPOSE-PIED GAUCHE	1 2 3 4 5 6 7 8 9	
22A		00H04903292	MUELLE FIJACION ESTRIBERA MOLLA FISSAGGIO PREDELLINO PILLION FOOTREST SECURING	FEDER RESSORT	1 2 3 4 5 6 7 8 9	

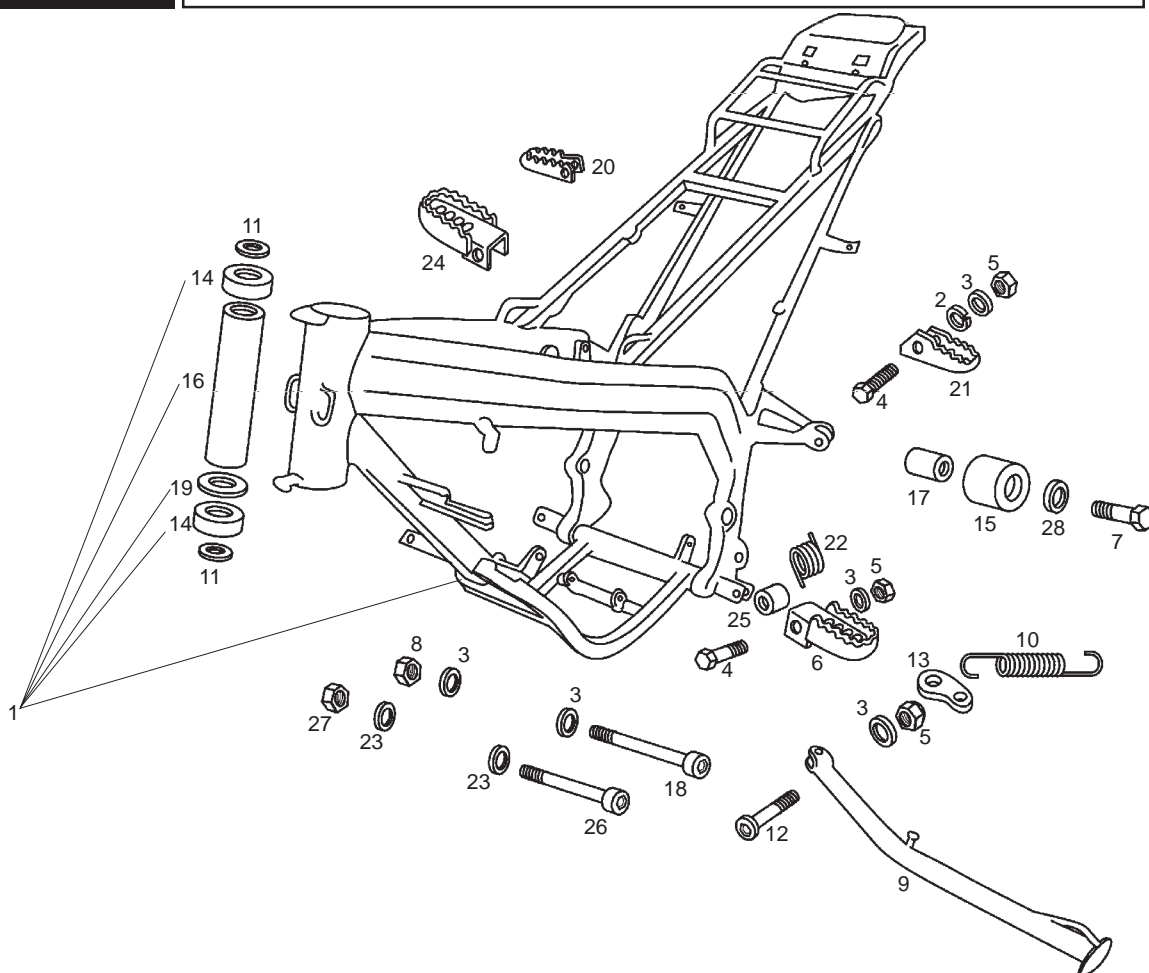

Fig.	Ver.	COD. KOD.	DESCRIPCIÓN DENOMINAZIONE NAME	BEZEICHNUNG DESIGNATION	MOD.	NOTAS NOTES NOTA MITSCHRIFT NOTES
23A		00402100001	ARANDELA PLANA D10 RONDELLA WASHER	SCHEIBE RONDELLE	1 2 3 4 5 6 7 8 9	
24A		00H02201302	SCTO.ESTRIBERA DERECHA PILOTO APPOG.DES. RIGHT FOOTREST	FUSSRASTER RECHTS REPOSE PIED DROIT	1 2 3 4 5 6 7 8 9	
25A		00002215152	CASQUILLO FIJACION ESTRIBERA GIUNTO SEAL	DICHTRING JOINT	1 2 3 4 5 6 7 8 9	
26A		00H03000272	TORNILLO FIJ.DT.MTO.ALL.10M150X100 VITE SCREW	SCHRAUBE VIS	1 2 3 4 5 6 7 8 9	
27A		00262100032	TUERCA AUTOBLOCANTE 10M150 DADO NUT	MUTTER ECROU	1 2 3 4 5 6 7 8 9	
28A		00003306570	ARANDELA FIJACION RONDELLA WASHER	SCHEIBE RONDELLE	1 2 3 4 5 6 7 8 9	

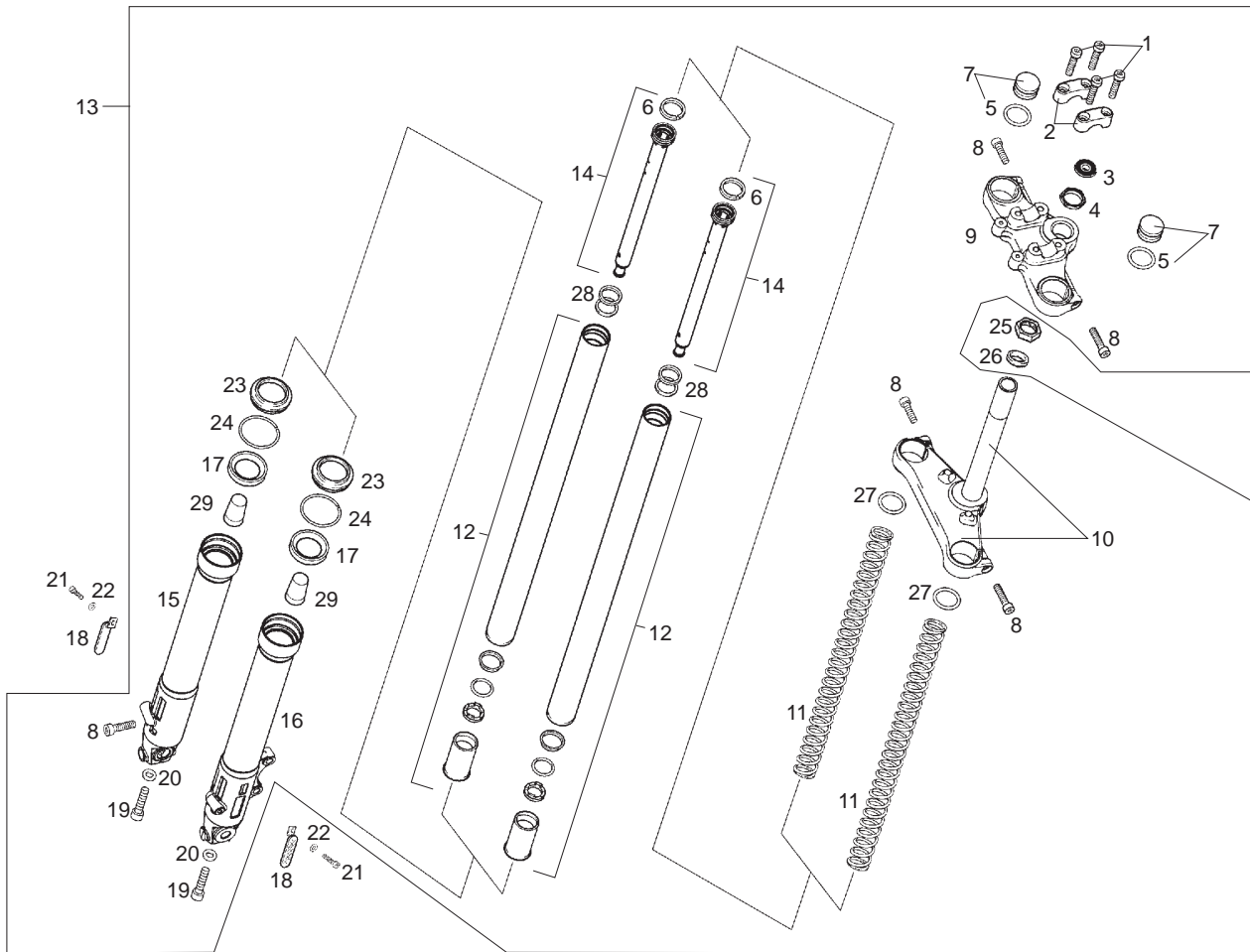

Fig.	Ver.	COD. KOD.	DESCRIPCIÓN DENOMINAZIONE NAME	BEZEICHNUNG DESIGNATION	MOD.	NOTAS NOTES NOTA MITSCHRIFT NOTES
01A		863143	TORNILLO M8X40 VITE SCREW	SCHRAUBE VIS	1 2 3 4 5 6 7 8 9	
02A		863144	PUENTE FIJACION MANILLAR CAVALLOTTO CLAMP	BEF.-SCHELLE ENTRETOISE	1 2 3 4 5 6 7 8 9	
03A		863145	GUARDAPOLVO PARAPOLVERE DUSTGUARD	STAUBFANGER POUSSIÈRE	1 2 3 4 5 6 7 8 9	
04A		00H00204601	TUERCA PLATINA SUPERIOR DADO NUT	MUTTER ECROU	1 2 3 4 5 6 7 8 9	
05A		863146	ANILLO TORICO ANELLO TORICO O-RING	O-RING JOINT	1 2 3 4 5 6 7 8 9	
06A		863147	ANILLO PISTON HIDRAULICO ANELLO RING	RING JOINT	1 2 3 4 5 6 7 8 9	
07A		863148	CTO TAPON PIERNA HORQUILLA TAPPO GAMBA FORCELLA FORK TUBE CAP	PFROPFEN F. GABELSCHENKEL BOUCHON	1 2 3 4 5 6 7 8 9	
08A		863149	TORNILLO M8X35 VITE SCREW	SCHRAUBE VIS	1 2 3 4 5 6 7 8 9	
09A		863150	PLATINA SUPERIOR FLANGIA SUP. FORCELLA HANDLEBAR LOCK CLAMP	BUGEL ETRIER FIX. GUIDON	1 2 3 4 5 6 7 8 9	
10A		863151	CTO TIJA PLATINA FUSTO PIASTRA LOWER TRIPLE CLAMP	SATTELSTANGE PLATINE INF. AVEC PIVOT	1 2 3 4 5 6 7 8 9	
11A		863152	MUELLE HORQUILLA MOLLA FORCELLA FORK SPRING	GABELFEDER RESSORT DE FOURCHE	1 2 3 4 5 6 7 8 9	

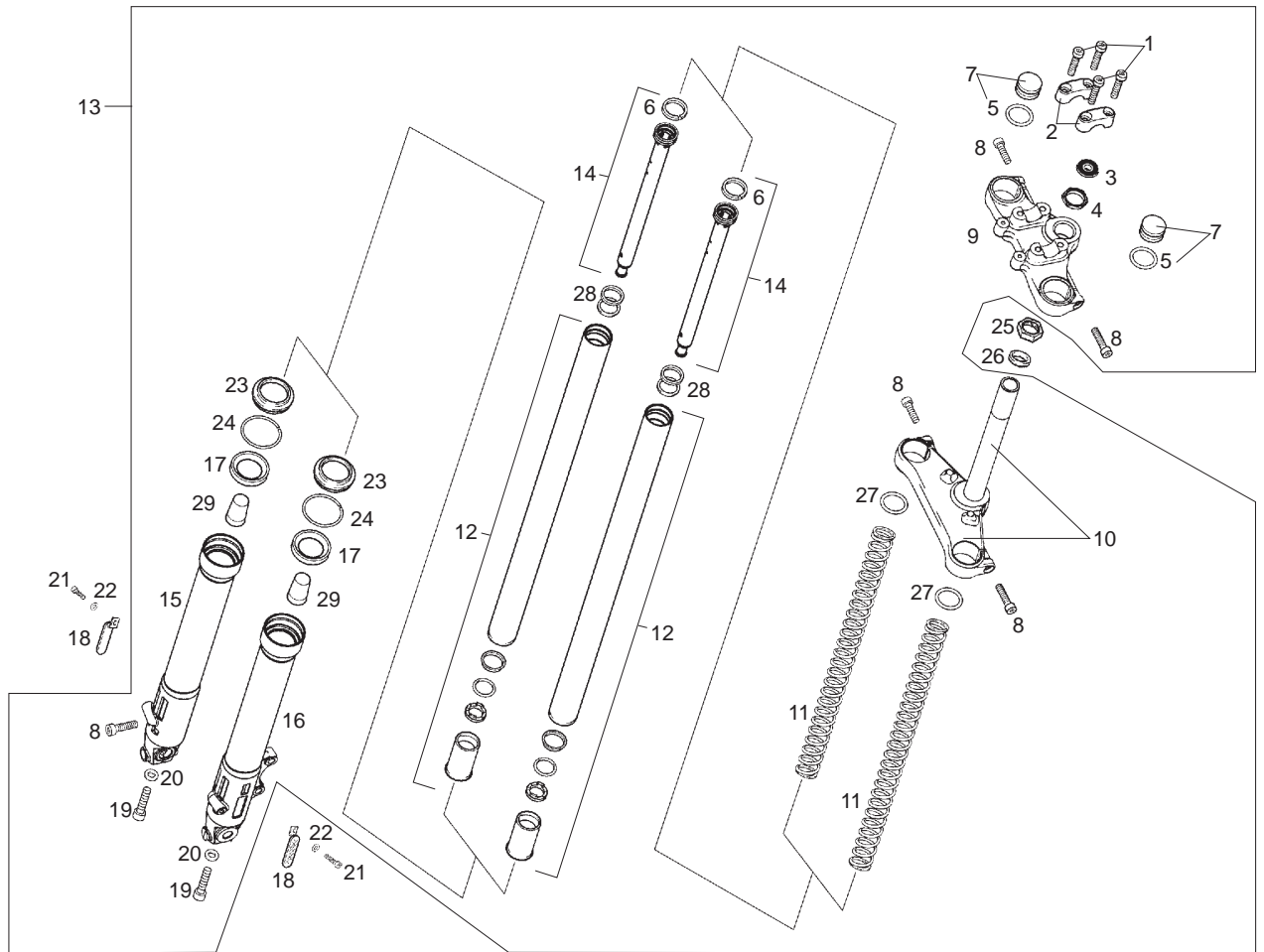

Fig.	Ver.	COD. KOD.	DESCRIPCIÓN DENOMINAZIONE NAME	BEZEICHUNG DESIGNATION	MOD.	NOTAS NOTES NOTA MITSCHRIFT NOTES
12A		863153	CTO BARRA HORQUILLA BARRA GAMBA FORCELLA FORK BAR	GABELSTANKE BARRE DE FOURCHE	1 2 3 4 5 6 7 8 9	
13A		861001	CTO HORQUILLA FORCELLA DIRETT FORK ASSY	LENKGABEL FOURCHE DIRITICE	1 2 3 4 5 6 7 8 9	
14A		863154	SCTO TUBO HIDRAULICO TUBO IDRAULICO DAMPER TUBE	HYDRAULIKROHR TUBE HYDRAULIQUE	1 2 3 4 5 6 7 8 9	
15A		863155	PIERNA HORQUILLA DERECHA GAMBA FORCELLA DE. RH. FORK TUBE LOWER	PFROPFEN F. GABELSCHENKEL RE. BOUCHON DROITE	1 2 3 4 5 6 7 8 9	
16A		863156	PIERNA HORQUILLA IZQUIERDA GAMBA FORCELLA SI. LH. FORK TUBE LOWER	PFROPFEN F. GABELSCHENKEL LI. BOUCHON GAUCHE	1 2 3 4 5 6 7 8 9	
17A		863157	RETEN PIERNA HORQUILLA PARAOILIO SEAL	DICHTRING JOINT	1 2 3 4 5 6 7 8 9	
18A		00H01802081	CAPTAFAROS CATARIFRANGENTE REFLECTOR	TRAHLER CATADIOPTRE	1 2 3 4 5 6 7 8 9	
19A		863158	TORNILLO M10X35 VITE SCREW	SCHRAUBE VIS	1 2 3 4 5 6 7 8 9	
20A		863159	ARANDELA COBRE RONDELLA WASHER	SCHEIBE RONDELLE	1 2 3 4 5 6 7 8 9	
21A		00008061500	TORNILLO C/RED. ALLEN 6M100X16 VITE SCREW	SCHRAUBE VIS	1 2 3 4 5 6 7 8 9	
22A		00031106000	ARANDELA PLANA D6 RONDELLA WASHER	SCHEIBE RONDELLE	1 2 3 4 5 6 7 8 9	

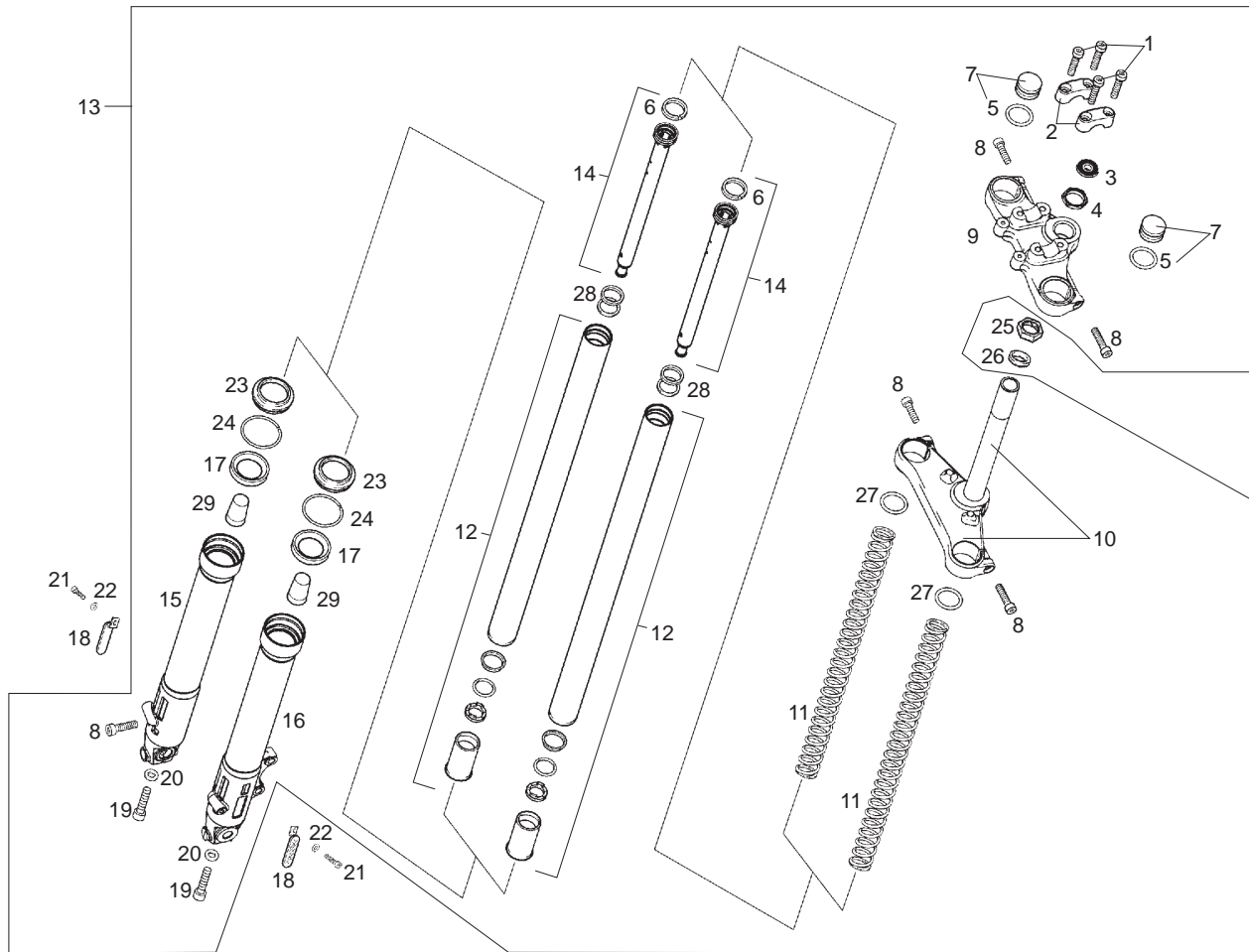

Fig.	Ver.	COD. KOD.	DESCRIPCIÓN DENOMINAZIONE NAME	BEZEICHNUNG DESIGNATION	MOD.	NOTAS NOTES NOTA MITSCHRIFT NOTES
23A		863160	GUARDAPOLVO PIERNA HORQUILLA PARAPOLVERE DUSTGUARD	STAUBFANGER POUSSIÈRE	1 2 3 4 5 6 7 8 9	
24A		863161	ANILLO RETEN ACEITE ANELLO FERMA PARAOLIO O-RING	O-RING JOINT DE JAUGE	1 2 3 4 5 6 7 8 9	
25A		00G00200112	TUERCA FIJACION TIJA DADO NUT	MUTTER ECROU	1 2 3 4 5 6 7 8 9	
26A		00D00200761	GUARDAPOLVO DIRECCION PARAPOLVERE DUSTGUARD	STAUBFANGER POUSSIÈRE	1 2 3 4 5 6 7 8 9	
27A		863162	ARANDELA RONDELLA WASHER	SCHEIBE RONDELLE	1 2 3 4 5 6 7 8 9	
28A		863163	MUELLE PISTON HIDRAULICO MOLLA SPRING	FEDER RESSORT	1 2 3 4 5 6 7 8 9	
29A		863164	CASQUILLO CONICO GHIERA BUSHING	BUCHSE ENTRETOISE	1 2 3 4 5 6 7 8 9	

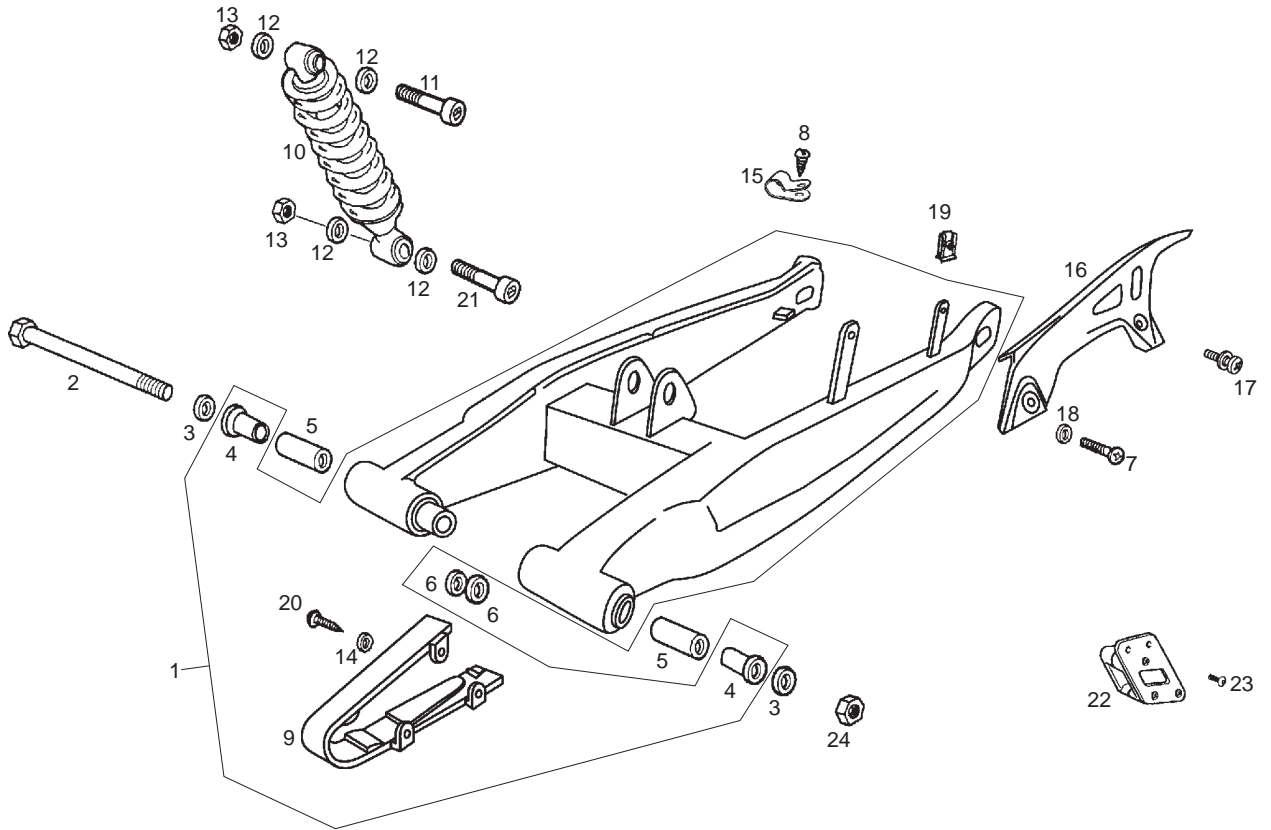

Fig.	Ver.	COD. KOD.	DESCRIPCIÓN DENOMINAZIONE NAME	BEZEICHNUNG DESIGNATION	MOD.	NOTAS NOTES NOTA MITSCHRIFT NOTES
01A		00H00308971	R-CTO BASCULANTE C/CASQUILLOS SUBRIBALTABILE SWING ARM SUB-ASSY	SCHWINGENACHSE BRAS OSCILLANT	1 2 3 4 5 6 7 8 9	
02A		00H01304202	CTO. EJE RDA. TRAS. ASSE RUOTA POST. REAR WHEEL AXLE	HINTERRADACHSE AXE ROUE ARRIERE	1 2 3 4 5 6 7 8 9	
03A		00003112322	ARANDELA EJE RUEDA. RONDELLA WASHER	SCHEIBE RONDELLE	1 2 3 4 5 6 7 8 9	
04A		00002503230	CASQUILLO EJE BASCTE GHIERA ASSE RIBALTABILE SWING ARM BUSHING	BUCHSE ENTRETOISE AXE BRAS OSCIL	1 2 3 4 5 6 7 8 9	
05A		00H00301401	CASQUILLO GHIERA ORECCHIA MOTORE ENGINE BRACKET BUFFER BUSHING	BUCHSE ENTRETOISE AXE BRAS OSCIL	1 2 3 4 5 6 7 8 9	
06A		00D01300192	ARANDELA EJE RONDELLA WASHER	SCHEIBE RONDELLE	1 2 3 4 5 6 7 8 9	
07A		00012061200	TORNILLO 6M100X12 VITE SCREW	SCHRAUBE VIS	1 2 3 4 5 6 7 8 9	
08A		00011041300	TORNILLO AUTR. C/CRUZ 4,8 X 13 VITE SCREW	SCHRAUBE VIS	1 2 3 4 5 6 7 8 9	
09A		00H01803331	PLACA ROZAMTO.CADENA. PIASTRAATTRITO CATENA CHAIN FORCHIN PLATE	KETTEN-REIBPLATTE PLAQUE GLISSEMENT CHAINE	1 2 3 4 5 6 7 8 9	
10A		00H01508191	CTO.AMORTIGUADOR AMMORTIZZATORE SHOCK ABSORBER.	FEDERBEIN AMORTISSEUR	1 2 3 4 5 6 7 8 9	
11A		00H00303892	TORNILLO FIJ.SUP.AMORTIGUADOR VITE SCREW	SCHRAUBE VIS	1 2 3 4 5 6 7 8 9	

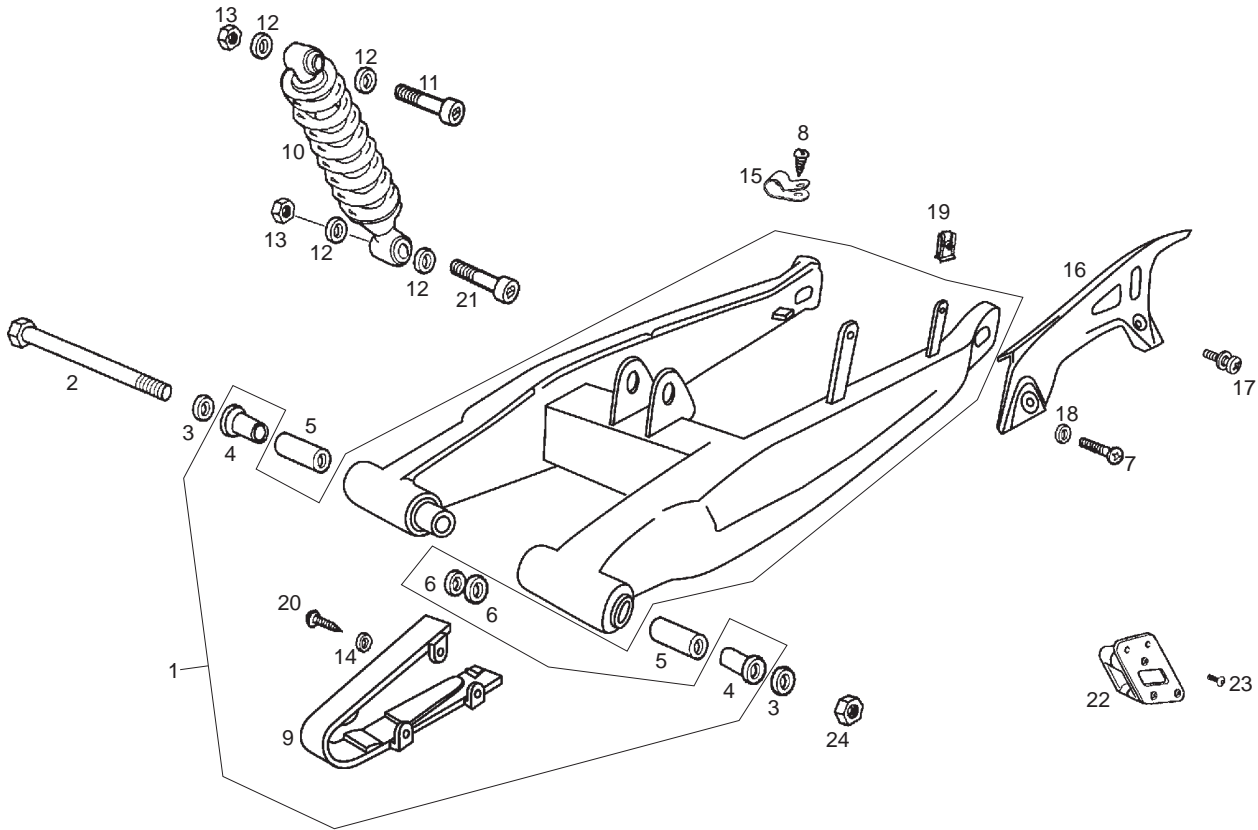

Fig.	Ver.	COD. KOD.	DESCRIPCIÓN DENOMINAZIONE NAME	BEZEICHUNG DESIGNATION	MOD.	NOTAS NOTES NOTA MITSCHRIFT NOTES
12A		00003115422	ARANDELA RONDELLA WASHER	SCHEIBE RONDELLE	1 2 3 4 5 6 7 8 9	
13A		00023112000	TUERCA AUTOBLOCANTE 12M175 DADO NUT	MUTTER ECROU	1 2 3 4 5 6 7 8 9	
14A		00000031050	ARANDELA PLANA D5 RONDELLA WASHER	SCHEIBE RONDELLE	1 2 3 4 5 6 7 8 9	
15A		00H01501811	BRIDA FLANGIA CLAMP	BEF.-SCHELLE ENTRETOISE	1 2 3 4 5 6 7 8 9	
16A		00H01508181	CUBRECADENAS COPRICATENA CHAIN COVER	KETTENSCHUTZ COUVRE CHAINE	1 2 3 4 5 6 7 8 9	
17A		00H05900021	SCTO TORNILLO 6M100X16 VITE SCREW	SCHRAUBE VIS	1 2 3 4 5 6 7 8 9	
18A		00D01200171	ARANDELA RONDELLA WASHER	SCHEIBE RONDELLE	1 2 3 4 5 6 7 8 9	
19A		00D01501371	TUERCA FIJACION D6 DADO NUT	MUTTER ECROU	1 2 3 4 5 6 7 8 9	
20A		00011141300	TORNILLO AUT.C/CR.NG.4,8X13 VITE SCREW	SCHRAUBE VIS	1 2 3 4 5 6 7 8 9	
21A		00H00300912	TORN. INF. AMORT. 12 X 45 VITE FISSAGGIO AMORT. SHOCK ABSORBER SEC. SCREW	SOTSSDMPFER BEFESTIGUNGSM VIS FIXATION AMORTISSEUR	1 2 3 4 5 6 7 8 9	
22A		00H01502871	CTO GUIA CADENA GUIDA CATENA CHAIN GUIDE	GLEITBAHN GUIDE CHAINE	1 2 3 4 5 6 7 8 9	

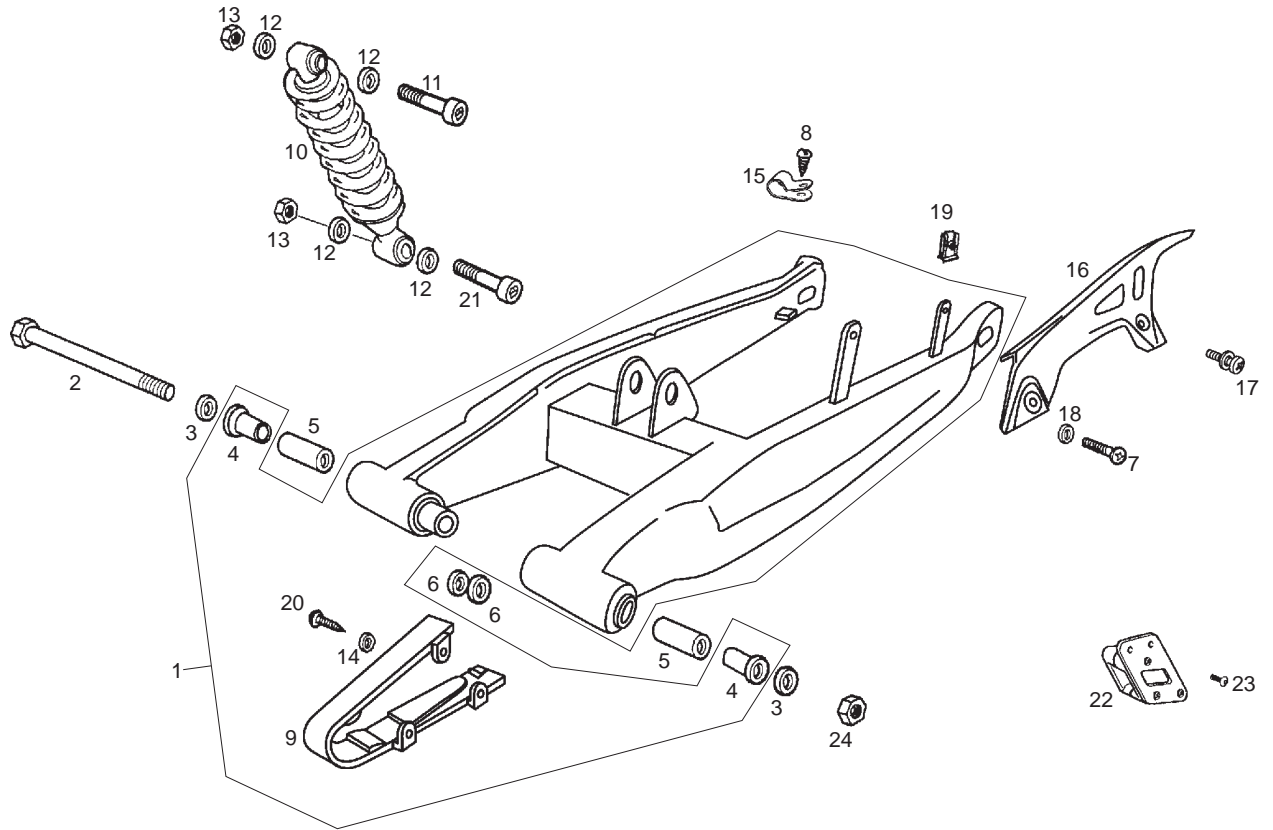

Fig.	Ver.	COD. KOD.	DESCRIPCIÓN DENOMINAZIONE NAME	BEZEICHNUNG DESIGNATION	MOD.	NOTAS NOTES NOTA MITSCHRIFT NOTES
23A		00012061000	TORNILLO C/REDONDA 6X10 VITE SCREW	SCHRAUBE VIS	1 2 3 4 5 6 7 8 9	
24A		00262120032	TUERCA 12M150 DADO NUT	MUTTER ECROU	1 2 3 4 5 6 7 8 9	

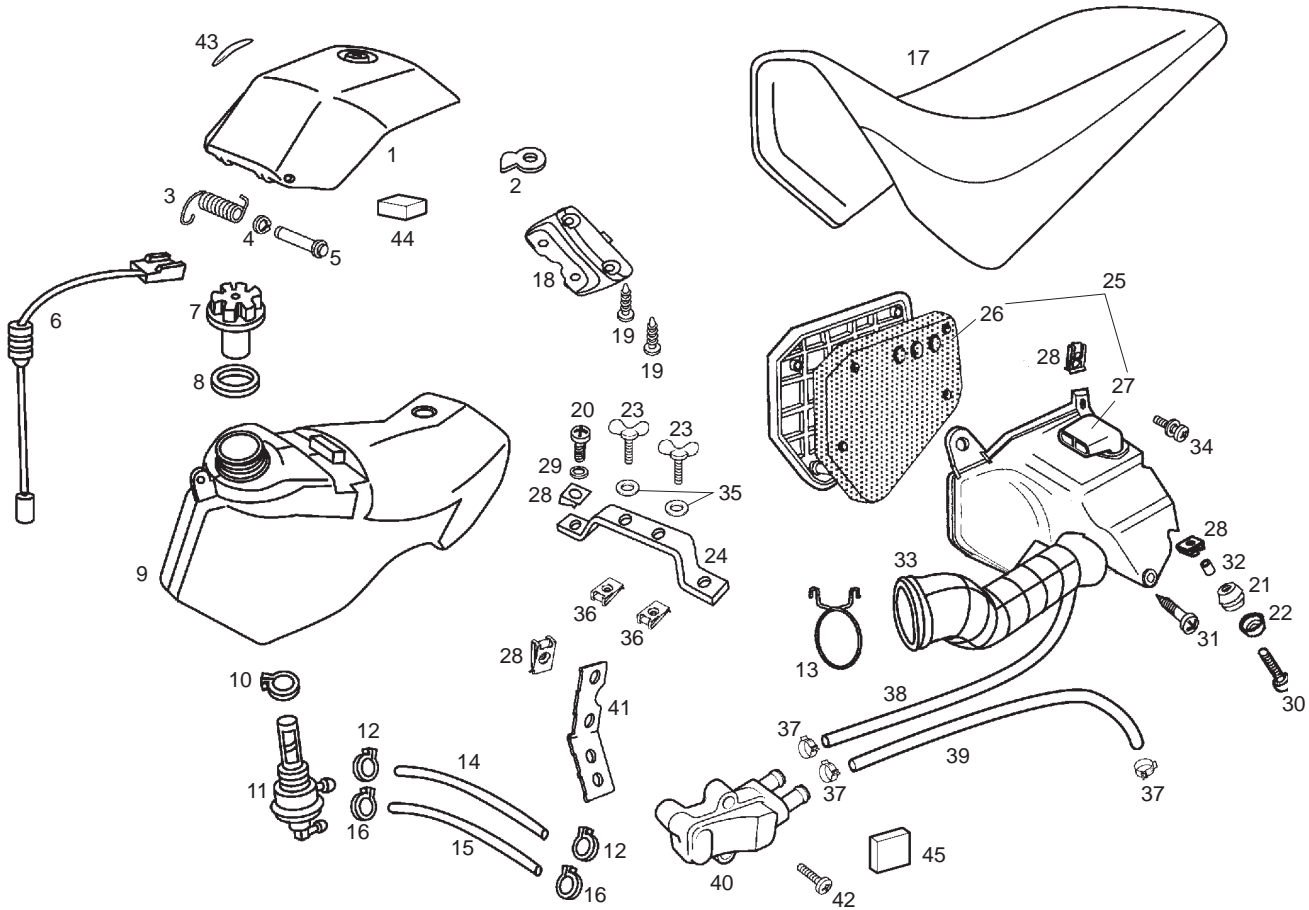

Fig.	Ver.	COD. KOD.	DESCRIPCIÓN DENOMINAZIONE NAME	BEZEICHNUNG DESIGNATION	MOD.	NOTAS NOTES NOTA MITSCHRIFT NOTES
01A		00H00404687	TAPA SUPERIOR DEPOSITO SUBCOMP.CARCASSA SUP.SERB. TOP TANK FRAME	TANKKLAPPE COUVERCLE DE RESERVOIR	1 2 3 4 5 6 7 8 9	
02A		00H00604141	PALANCA CIERRE LEVA LEVER	SCHLOSS-VERSCHLUSSHEBEL LEVIER FERMETURE SELLE	1 2 3 4 5 6 7 8 9	
03A		00H06303762	MUELLE ARTIC.TAPA DEPOSITO MOLLA ARTIC. COPER. SUP. SERB. SPRING	RITZELFEDER RESSORT	1 2 3 4 5 6 7 8 9	
04A		00047030400	ANILLO SEGURIDAD D4 ANELLO SICUREZZA ASSI PIN SECURING CIRCLIP	SICHERHEITSRING ACHSE ANNEAU SECURITE AXE	1 2 3 4 5 6 7 8 9	
05A		00H06303752	EJE ARTIC.TAPA DEPOSITO ASSE ARTIC. COPER. SUP.SERB. AXLE	STIFT AXE	1 2 3 4 5 6 7 8 9	
06A		00H04302181	CTO NIVEL GASOLINA LIVELLO BENZINA GAS LEVEL SENSOR ASSY.	KRAFTSTOFFSTAND ENSEMBLE FLOTTEUR ESSENCE	1 2 3 4 5 6 7 8 9	UNTIL FRAME 7H379833
06B		864489	CTO NIVEL GASOLINA LIVELLO BENZINA GAS LEVEL SENSOR ASSY.	KRAFTSTOFFSTAND ENSEMBLE FLOTTEUR ESSENCE	1 2 3 4 5 6 7 8 9	SINCE FRAME 7H379834
07A		00F00400131	CTO. TAPON DEPOSITO GASOLINA TAPPO SERBATOIO BENZINA FUEL TANK CAP ASSY	FUEL TANK CAP ASSY ENS.BOUCHON RESERV.ESSENCE V.B	1 2 3 4 5 6 7 8 9	
08A		00F00400771	R-ARANDELA TAPON DEPOSITO RONDELLA TAPPO SERBATOIO FUEL TANK CAP WASHER	SCHEIBE F.TANKDECKEL R-RONDELLE BOUCHON RESERVOIR	1 2 3 4 5 6 7 8 9	
09A		00H00406011	DEPOSITO.GASOLINA SERBATOIO BENZINA FUEL TANK	BENZINTANK RESERVOIR ESSENCE	1 2 3 4 5 6 7 8 9	
10A		00G00400501	ABRAZADERA FASCETTA FISSAGGIO RUBINETTO FUEL COCK SECURING CLAMP	BEF.-SCHELLE F.HAHN BRIDE FIXATION ROBINET	1 2 3 4 5 6 7 8 9	

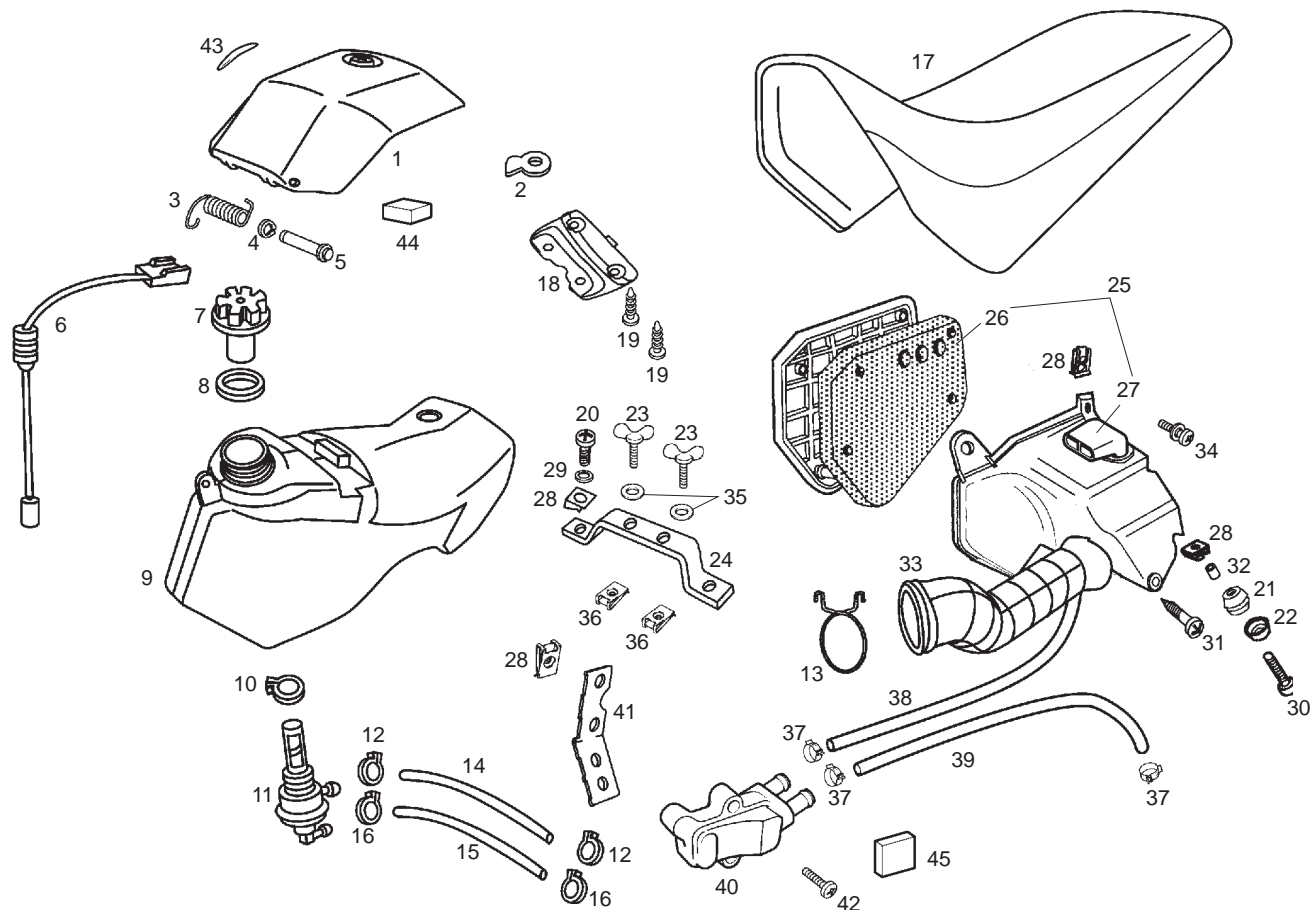

Fig.	Ver.	COD. KOD.	DESCRIPCIÓN DENOMINAZIONE NAME	BEZEICHUNG DESIGNATION	MOD.	NOTAS NOTES NOTA MITSCHRIFT NOTES
11A		00G00400181	CTO GRIFO GASOLINA RUBINETTO BENZINA FUEL COCK ASSY	KRAFTSTOFFHAHN UNTERDRUCK ENSEMBLE ROBINET ESSENCE	1 2 3 4 5 6 7 8 9	
12A		00D03700131	ABRAZADERA ELASTICA FASCETTA ELASTICA TUBO BENZINA FUEL PIPE ELASTIC CLAMP	ELAST.KLAMMER GASLEITUNG CRAMPON ELASTIQUE TUBE ESSE	1 2 3 4 5 6 7 8 9	
13A		00G03204272	MUELLE TUBO ADMISION ANELLO CARB. AIR INTAKE TUBE	SCHAUCHSCHELLE COLLIER	1 2 3 4 5 6 7 8 9	
14A		00F00403321	TUBO GASOLINA TUBO BENZINA FUEL PIPE	BENZINSCHLAUCH TUYAU ESSENCE	1 2 3 4 5 6 7 8 9	
15A		00H06201061	TUBO DEPRESSION TUBO DEPRESSIONE DEPRESSION PIPE	BENZINSCHLAUCH TUYAU ESSENCE	1 2 3 4 5 6 7 8 9	
16A		00F03710131	ABRAZADERA ELASTICA FASCETTA ELASTICA CLAMP	BEF.-SCHELLE ENTRETOISE	1 2 3 4 5 6 7 8 9	
17A		00H00622013	CTO SILLIN COMP. SELLINO SEAT	SITZBANK SELLE	1 2 3	
17B		8635710002	CTO SILLIN COMP. SELLINO SEAT	SITZBANK SELLE	4 5 6	
17C		8635710003	CTO SILLIN COMP. SELLINO SEAT	SITZBANK SELLE	7 8 9	
18A		00H00600341	SUPLEMENTO BASE SILLIN SUPPLEMENTO SELLINO SEAT SUPPLEM.	ZUBEHOR SITZBANK SUPL.SELLE	1 2 3 4 5 6 7 8 9	
19A		00011051801	TORNILLO PARA PLASTICO 5.1 X 18 VITE SCREW	SCHRAUBE VIS	1 2 3 4 5 6 7 8 9	

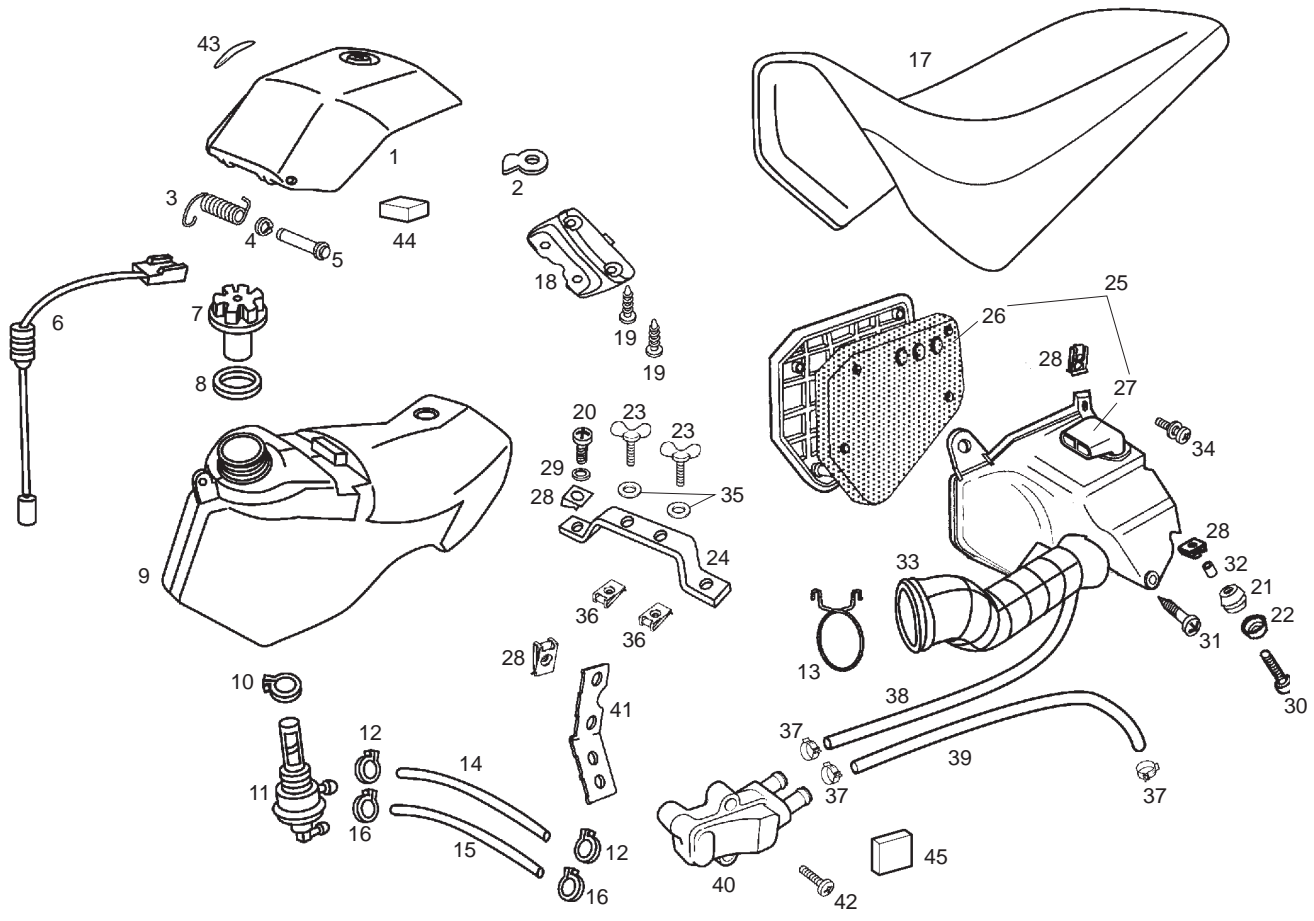

Fig.	Ver.	COD. KOD.	DESCRIPCIÓN DENOMINAZIONE NAME	BEZEICHNUNG DESIGNATION	MOD.	NOTAS NOTES NOTA MITSCHRIFT NOTES
20A		00012061200	TORNILLO C/CRUZ 6M100X12 VITE SCREW	SCHRAUBE VIS	1 2 3 4 5 6 7 8 9	
21A		00008915020	PROTECCION CABLES PROTEZIONE CAVI RUBBER, CABLE PROTECTOR	GUMMI PASSE-CABLE	1 2 3 4 5 6 7 8 9	
22A		00D01500552	CAZOLETA SCADELLINO FISSAGGIO HOUSING	ABDECKSCHEIBE CUVETTE	1 2 3 4 5 6 7 8 9	
23A		00H06101231	TORNILLO MARIPOSA 5X12 VITE SCREW	SCHRAUBE VIS	1 2 3 4 5 6 7 8 9	
24A		00H00404051	PUENTE FIJ. DEPOSITO. SUPPORTO INF. SERBATOIO LOWER FUEL TANK BRACKET	LOWER FUEL TANK BRACKET GPRËRË SUPPORT INFËRIEUR RËSERVOIR ES	1 2 3 4 5 6 7 8 9	
25A		00H01809541	CTO CAJA FILTRO CASSA FILTRO AIR FILTER BOX	FILTERKASTEN ENSEMBLE BOITE FILTRE	1 2 4 5 7 8	
25B		00H06007211	CTO CAJA FILTRO C/TUBO ESCANDINAVIA CASSA FILTRO AIR FILTER BOX	FILTERKASTEN ENSEMBLE BOITE FILTRE	3 6 9	
26A		00H03209251	ESPUMA FILTRO AIRE ESPANSO FILTRO ARIA AIR FILTER MESH	LUFTFILTERSCHAUM FILTRE AIR	1 2 4 5 7 8	
26B		00H03201251	ESPUMA FILTRO AIRE ESPANSO FILTRO ARIA AIR FILTER MESH	LUFTFILTERSCHAUM FILTRE AIR	3 6 9	
27A		00H03208491	TUBO ASPIRACION CAJA FILTRO TUBO ASPIRAZIONE AIR INTAKE	SAUGROHR TUBE DIASPIRATION	1 2 4 5 7 8	
27B		00D03210491	TUBO ASPIRACION CAJA FILTRO TUBO ASPIRAZIONE AIR INTAKE	SAUGROHR TUBE DIASPIRATION	3 6 9	

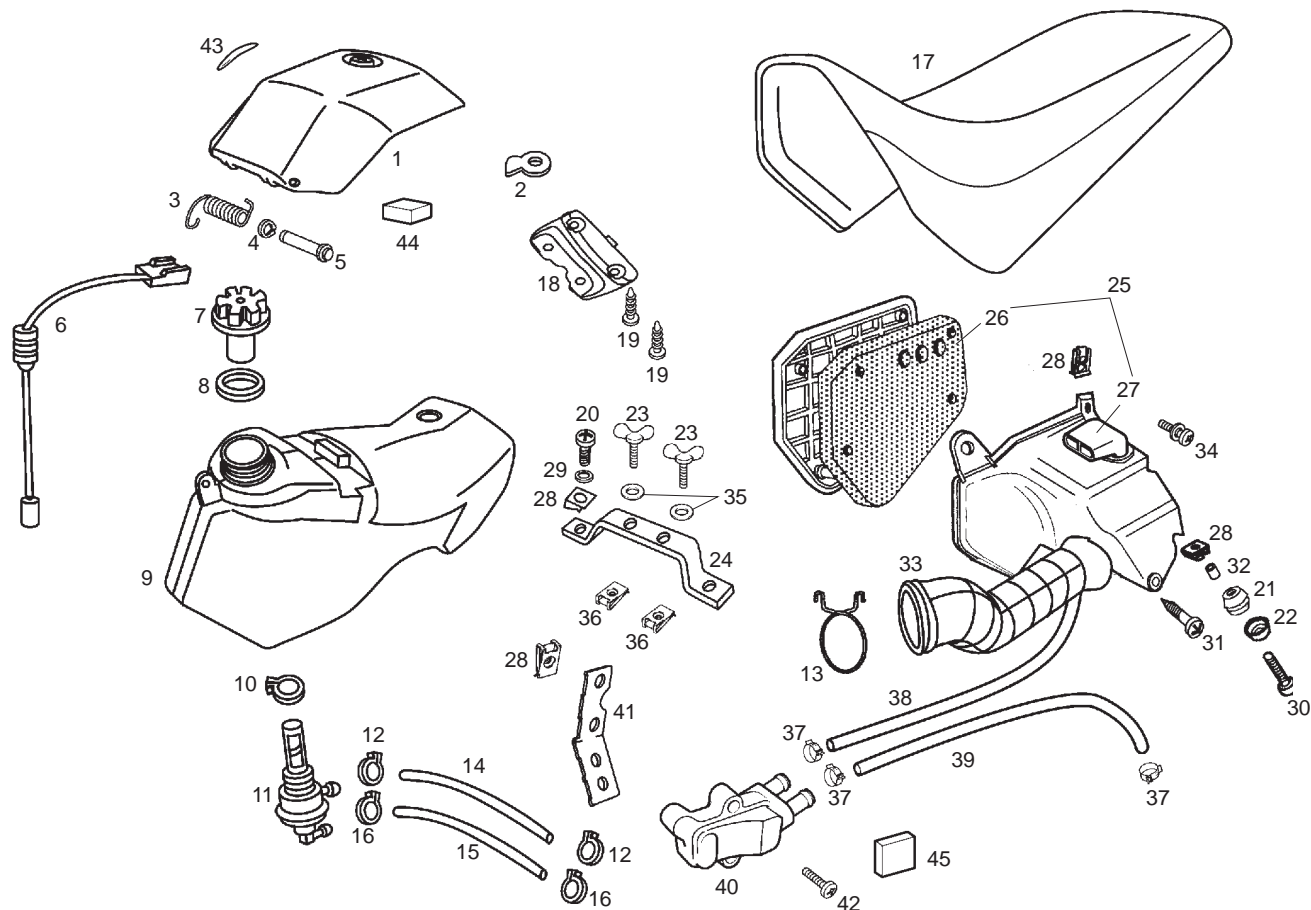

Fig.	Ver.	COD. KOD.	DESCRIPCIÓN DENOMINAZIONE NAME	BEZEICHUNG DESIGNATION	MOD.	NOTAS NOTES NOTA MITSCHRIFT NOTES
28A		00D01501371	TUERCA FIJACION D6 DADO NUT	MUTTER ECROU	1 2 3 4 5 6 7 8 9	
29A		00D01200171	ARANDELA RONDELLA WASHER	SCHEIBE RONDELLE	1 2 3 4 5 6 7 8 9	
30A		00012161600	TORNILLO C/CRUZ.NG.6M100X16 VITE SCREW	SCHRAUBE VIS	1 2 3 4 5 6 7 8 9	
31A		00073481964	TORNILLO AUTR.C/CRUZ 4,8 X 19. VITE SCREW	SCHRAUBE VIS	1 2 3 4 5 6 7 8 9	
32A		00D01500471	CASQ. SILENT. SILENC. GHIERA BUSHING	FUHRUNGSBUCHSE GABELSCHENK ENTRETOISE	1 2 3 4 5 6 7 8 9	
33A		00H03207261	TUBO ADMISION. TUBO AMMISSIONE AIR INTAKE HOSE	ENLAISROR HUNTER TUYAU DIADMISSION HUNTER	1 2 3 4 5 6 7 8 9	
34A		00H05900021	SCTO. TORNILLO 6M100X16 VITE SCREW	SCHRAUBE VIS	1 2 3 4 5 6 7 8 9	
35A		00D02600631	ARANDELA RONDELLA WASHER	SCHEIBE RONDELLE	1 2 3 4 5 6 7 8 9	
36A		00H01500691	TUERCA FIJACION DADO NUT	MUTTER ECROU	1 2 3 4 5 6 7 8 9	
37A		00H03802461	ABRAZADERA 15/8 W4 FLANGIA FLANGE	FLANSCH BRIDE	3 6 9	
38A		00H04200721	TUBO CONEXIÓN CAJA FILTRO - SAS TUBO CASSA FILTRO AIR FILTER BOX TUBE	FILTERKASTEN RHOR TUYAU ENSEMBLE BOITE FILTRE	3 6 9	

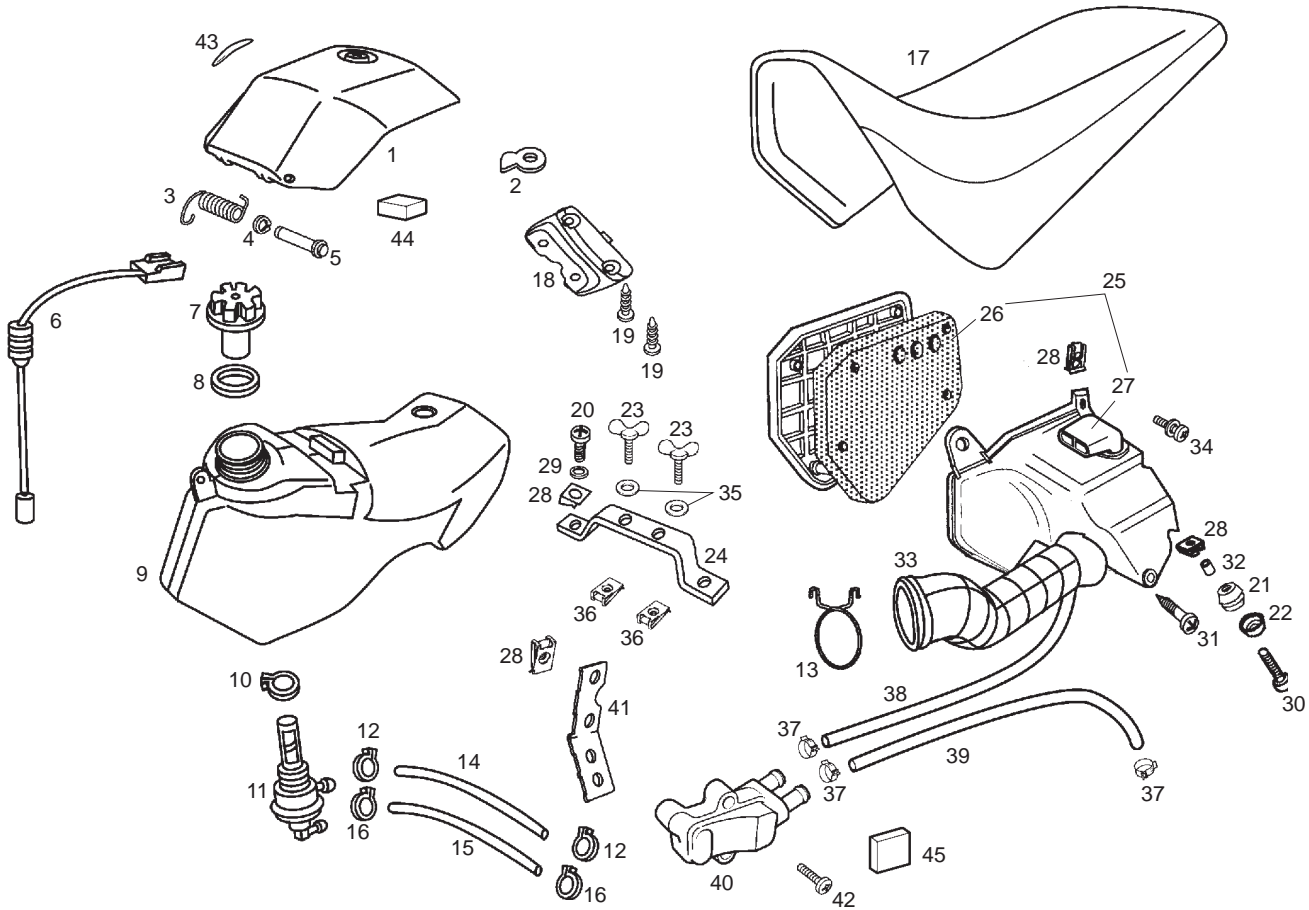

Fig.	Ver.	COD. KOD.	DESCRIPCIÓN DENOMINAZIONE NAME	BEZEICHNUNG DESIGNATION	MOD.	NOTAS NOTES NOTA MITSCHRIFT NOTES
39A		00H04202721	TUBO ENTRADA GASES CAJA SAS TUBO CASSA FILTRO AIR FILTER BOX TUBE	FILTERKASTEN RHOR TUYAU ENSEMBLE BOITE FILTRE	3 6 9	
40A		00H04200741	CTO CAJA AIRE SECUNDARIO CASSA SECONDARIA DI ARIA SECONDARY AIR BOX	SEKUNDÄRLUFT-KASTEN BOÎTE SECONDAIRE D'AIR	3 6 9	
41A		00H06500561	CARTELA SOPORTE CAJA SAS SUPPORTO CASSA DI ARIA AIR BOX SUPPORT	LUFT-KASTEN-UNTERSTÜTZUNG APPUI DE BOÎTE D'AIR	3 6 9	
42A		00012062500	TORNILLO C/CRUZ 6M100X25 VITE SCREW	SCHRAUBE VIS	3 6 9	
43A		00H00406521	CALCA PROTECCION TAPA ADESIVO DECAL	SCHRIFTZUG ADHESIF	1 2 3 4 5 6 7 8 9	
44A		00H00403831	TOPE TAPA DEPOSITO FERMO STOP	ANSCHLAG BUTEE	1 2 3 4 5 6 7 8 9	
45A		00H03800571	TOPE FERMÓ FERMO STOP	ANSCHLAG BUTEE	3 6 9	

**PIEZAS CON CALCAS
PARTS WITH DECALS**

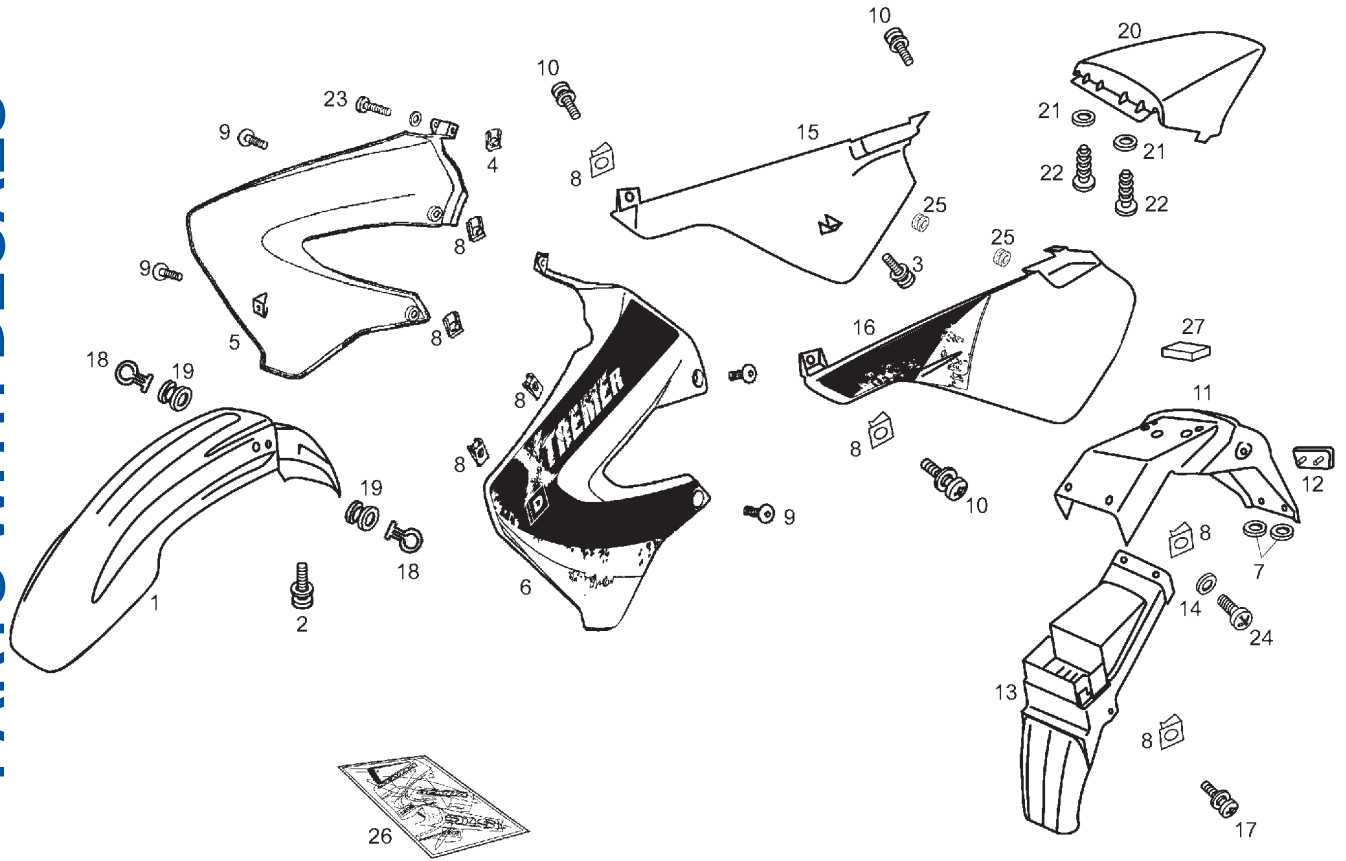
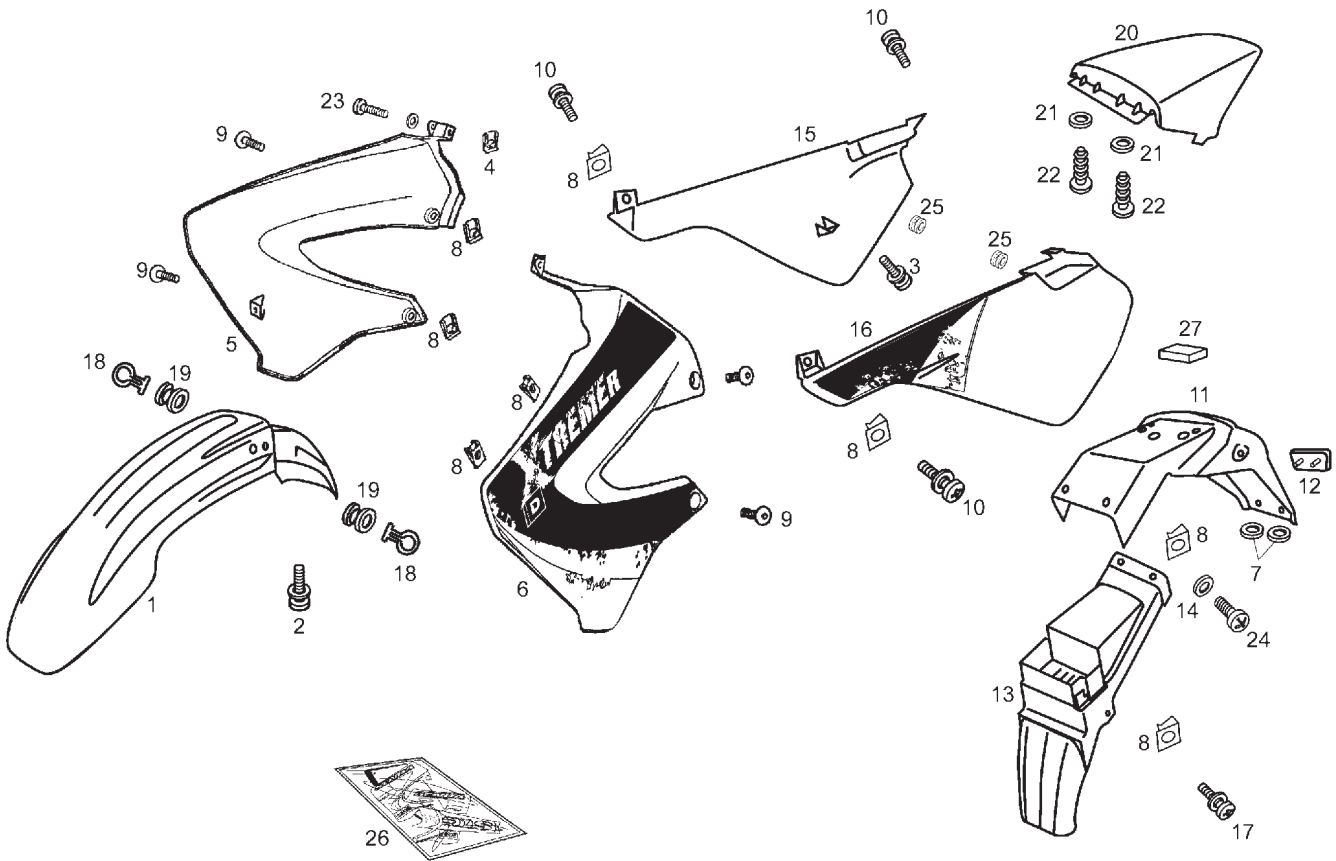

Fig.	Ver.	COD. KOD.	DESCRIPCIÓN DENOMINAZIONE NAME	BEZEICHUNG DESIGNATION	MOD.	NOTAS NOTES MITSCHRIFT
01A		00H00712024	GUARDABARRO DELANTERO PARAFANGO ANTERIORE FRONT MUDGUARD ASSY	KOTFLUGEL VORN GARDE-BOUE AVANT RGE	1 2 3	
01B		00H00712023	GUARDABARRO DELANTERO PARAFANGO ANTERIORE FRONT MUDGUARD ASSY	KOTFLUGEL VORN GARDE-BOUE AVANT RGE	4 5 6 7 8 9	
02A		00H05900021	SCTO TORNILLO 6M100X16 VITE SCREW	SCHRAUBE VIS	1 2 3 4 5 6 7 8 9	
03A		00H05900021	SCTO TORNILLO 6M100X16 VITE SCREW	SCHRAUBE VIS	1 2 3 4 5 6 7 8 9	
04A		00G04401462	TUERCA FIJACION D5 DADO NUT	MUTTER ECROU	1 2 3 4 5 6 7 8 9	
05A		86357200WA5	TAPA DELANTERA DERECHA COPERCHIO COVER	DECKEL COUVERCLE	1 2 3	
05B		86357200WN0	TAPA DELANTERA DERECHA COPERCHIO COVER	DECKEL COUVERCLE	4 5 6	
05C		86357200WB0	TAPA DELANTERA DERECHA COPERCHIO COVER	DECKEL COUVERCLE	7 8 9	
06A		86357300WA5	TAPA DELANTERA IZQUIERDA COPERCHIO COVER	DECKEL COUVERCLE	1 2 3	
06B		86357300WN0	TAPA DELANTERA IZQUIERDA COPERCHIO COVER	DECKEL COUVERCLE	4 5 6	
06C		86357300WB0	TAPA DELANTERA IZQUIERDA COPERCHIO COVER	DECKEL COUVERCLE	7 8 9	



**PIEZAS CON CALCAS
PARTS WITH DECALS**

Fig.	Ver.	COD. KOD.	DESCRIPCIÓN DENOMINAZIONE NAME	BEZEICHNUNG DESIGNATION	MOD.	NOTAS NOTES NOTA MITSCHRIFT NOTES
07A		00G06300671	ARANDELA RONDELLA WASHER	SCHEIBE RONDELLE	1 2 3 4 5 6 7 8 9	
08A		00D01501371	TUERCA FIJACION D6 DADO NUT	MUTTER ECROU	1 2 3 4 5 6 7 8 9	
09A		00G01503701	TORNILLO VITE SCREW	SCHRAUBE VIS	1 2 3 4 5 6 7 8 9	
10A		00F05900041	SCTO TORNILLO 6M100X16 VITE SCREW	SCHRAUBE VIS	1 2 3 4 5 6 7 8 9	
11A		00H00712341	SUPLEMEMTO GUARD.TRASERO SUPPLEMENTO PARAFANGO POST. SUPPLEM. REAR FENDER	ZUBEHOR STAUBFANGER HINTEN SUPL. GARDE BOUE AR.	1 2 3 4 5 6 7 8 9	
12A		00G04400752	CAPTAFAROS TRASERO ROJO CATARIFRANGENTE POSTERIORE R REAR REFLECTOR	RUCKS TRAHLER CATADIOPTRE ARRIERE	1 2 3 4 5 6 7 8 9	
13A		00H00705121	GUARDABARROS TRASERO PARAFANGO POSTERIORE REAR MUDGUARD	KOTFLUGEL HINTEN GARDE BOUE ARRIERE	1 2 3 4 5 6 7 8 9	
14A		00D01200171	ARANDELA RONDELLA WASHER	SCHEIBE RONDELLE	1 2 3 4 5 6 7 8 9	
15A		86357600WB0	TAPA LATERAL DERECHA COPERCHIO LAT. DES. RIGHT HAND SIDE COVER	SEITENDECKEL RECHTS PLAQUE LATERAL DROITE AVEC	1 2 3	
15B		86357800WB0	TAPA LATERAL DERECHA COPERCHIO LAT. DES. RIGHT HAND SIDE COVER	SEITENDECKEL RECHTS PLAQUE LATERAL DROITE AVEC	4 5 6	
15C		86390000WB0	TAPA LATERAL DERECHA COPERCHIO LAT. DES. RIGHT HAND SIDE COVER	SEITENDECKEL RECHTS PLAQUE LATERAL DROITE AVEC	7 8 9	

**PIEZAS CON CALCAS
PARTS WITH DECALS**

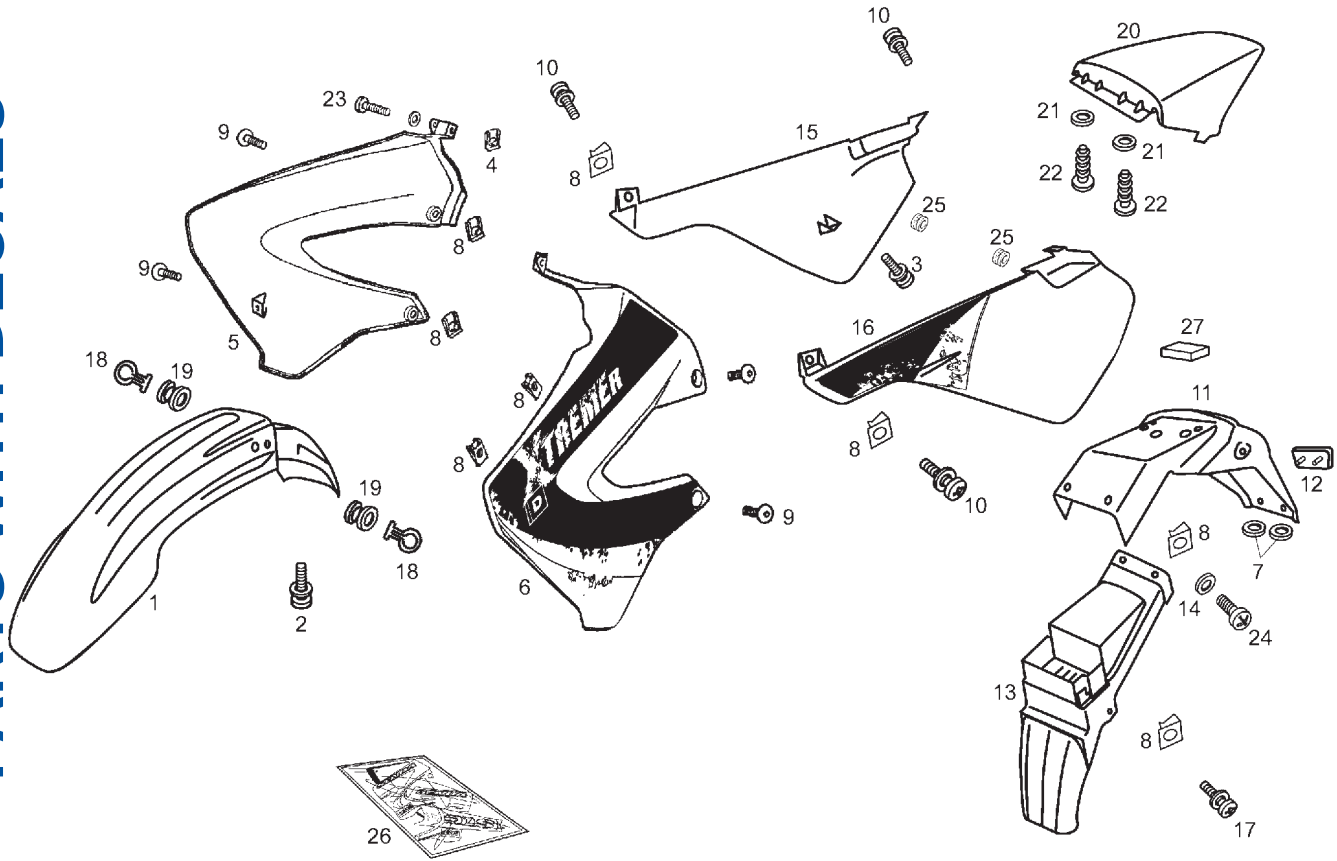
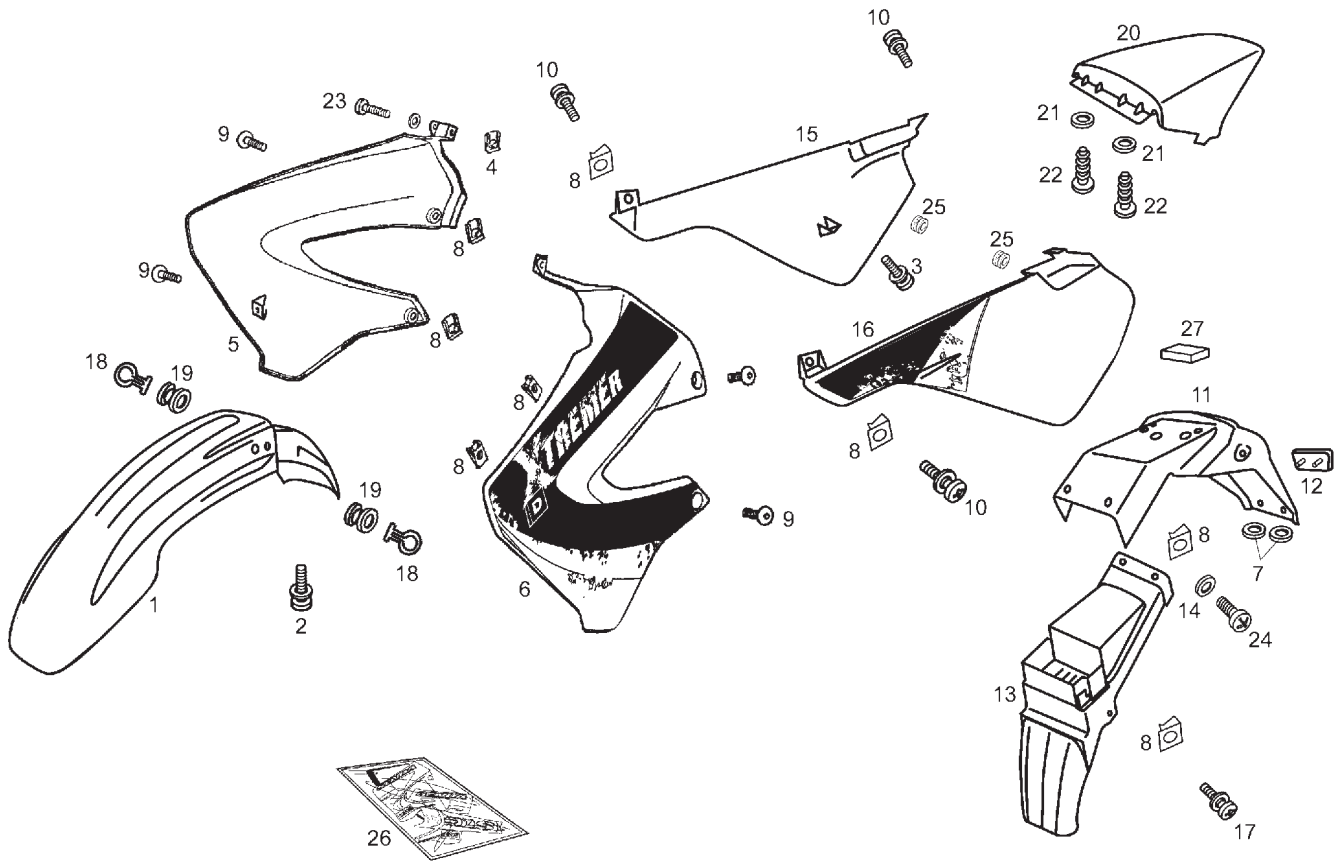

Fig.	Ver.	COD. KOD.	DESCRIPCIÓN DENOMINAZIONE NAME	BEZEICHNUNG DESIGNATION	MOD.	NOTAS NOTES NOTA MITSCHRIFT NOTES
16A		86357700WB0	TAPA LATERAL IZQUIERDA COPERCHIO LAT. SIN. LEFT HAND SIDE COVER	SEITENDECKEL- LINKS FLANC LAT.G.AVEC DECAL	1 2 3	
16B		86357900WB0	TAPA LATERAL IZQUIERDA COPERCHIO LAT. SIN. LEFT HAND SIDE COVER	SEITENDECKEL- LINKS FLANC LAT.G.AVEC DECAL	4 5 6	
16C		86390100WB0	TAPA LATERAL IZQUIERDA COPERCHIO LAT. SIN. LEFT HAND SIDE COVER	SEITENDECKEL- LINKS FLANC LAT.G.AVEC DECAL	7 8 9	
17A		00H05900021	SCTO TORNILLO 6M100X16 VITE SCREW	SCHRAUBE VIS	1 2 3 4 5 6 7 8 9	
18A		00H02201591	GUIA CABLES GUIDA CAVI CABLE GUIAE	HALTER F. BEF. BREMSSCHLAU SOUS-EN.SUP.FIX.TUYAU FREIN	1 2 3 4 5 6 7 8 9	
19A		00D01500021	PASACABLES PORTACAVI PARAFANGO GROMMET	GUMMI CAOUTCHOUC PASSE-CABLE	1 2 3 4 5 6 7 8 9	
20A		00H00618163	COLIN SILLIN COLIN SELLINO SEAT BASE	KOTFLUGEL HINTEN DOSSERET SELLE	1 2 3	
20B		00H00618166	COLIN SILLIN COLIN SELLINO SEAT BASE	KOTFLUGEL HINTEN DOSSERET SELLE	4 5 6 7 8 9	
21A		00000031050	ARANDELA PLANA D5 RONDELLA WASHER	SCHEIBE ROND.PLATE MECANISEE	1 2 3 4 5 6 7 8 9	
22A		00011051401	TORNILLO AUTRRCTE. 5 X14 VITE SCREW	SCHRAUBE VIS	1 2 3 4 5 6 7 8 9	
23A		00012152000	TORNILLO C/RED.CRUC. 5M80X20 VITE SCREW	SCHRAUBE VIS	1 2 3 4 5 6 7 8 9	



**PIEZAS CON CALCAS
PARTS WITH DECALS**

Fig.	Ver.	COD. KOD.	DESCRIPCIÓN DENOMINAZIONE NAME	BEZEICHNUNG DESIGNATION	MOD.	NOTAS NOTES NOTA MITSCHRIFT NOTES
24A		00012061200	TORNILLO 6M100X12 VITE SCREW	SCHRAUBE VIS	1 2 3 4 5 6 7 8 9	
25A		00H00501761	SILENTBLOCK FIJ. TAPAS LATERALES SILENTBLOCK SILENTBLOCK	SILENTBLOCK SILENTBLOCK	1 2 3 4 5 6 7 8 9	
26A		86358400WA5	JUEGO CALCAS SD R AZUL COMPL.ADESIVI DECALS ASSY	AUFKLEBERSATZ JEU ADHESIF	1 2 3	
26B		86358500WA5	JUEGO CALCAS SD R BLUE FRANCE COMPL.ADESIVI DECALS ASSY	AUFKLEBERSATZ JEU ADHESIF	1 2	ONLY FRANCE AUSTRIA
26C		86358400WN0	JUEGO CALCAS SD R NEGRA COMPL.ADESIVI DECALS ASSY	AUFKLEBERSATZ JEU ADHESIF	4 5 6	
26D		86358500WN0	JUEGO CALCAS SD R BLACK FRANCE COMPL.ADESIVI DECALS ASSY	AUFKLEBERSATZ JEU ADHESIF	4 5	ONLY FRANCE AUSTRIA
26E		86358400WB0	JUEGO CALCAS SD R BLANCA COMPL.ADESIVI DECALS ASSY	AUFKLEBERSATZ JEU ADHESIF	7 8 9	
26F		86358500WB0	JUEGO CALCAS SD R WHITE FRANCE COMPL.ADESIVI DECALS ASSY	AUFKLEBERSATZ JEU ADHESIF	7 8	ONLY FRANCE AUSTRIA
27A		00H05900621	ESPUMA ADESIVA ESPANSO FOAM	SCHAUM MOUSSE	1 2 3 4 5 6 7 8 9	

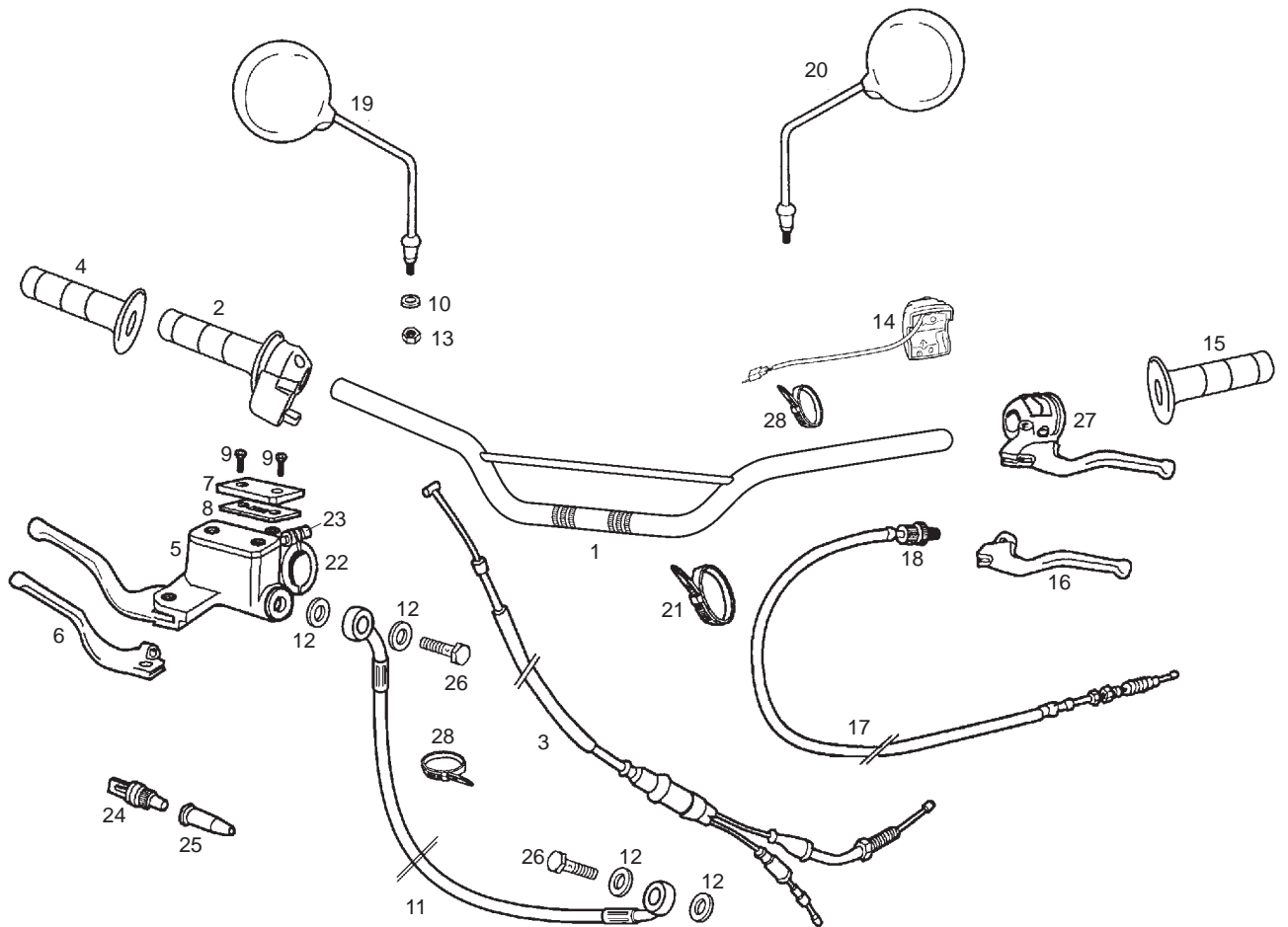

Fig.	Ver.	COD. KOD.	DESCRIPCIÓN DENOMINAZIONE NAME	BEZEICHUNG DESIGNATION	MOD.	NOTAS NOTES NOTA MITSCHRIFT NOTES
01A		00H00912012	MANILLAR MANUBRIO HANDLEBAR ASSY	LENKER GUIDON	1 2 3 4 5 6 7 8 9	
02A		00H02101621	CTO. PUÑO GAS MANOPOLA ACCELERATOR THROTTLE GRIP ASSEMBLY	GASGRIF POIGNEE DE GAZ COMPLETE	1 2 3 4 5 6 7 8 9	
03A		00H00931171	CABLE-FUNDA GAS CAVO-FODERO ACCELERA CABLE ASSY TRHOTTLE	GASKABEL GAINE ET CABLE DE GAZ	1 2 4 5 7 8	
03B		00H00934171	CABLE-FUNDA GAS SCANDINAVIA CAVO-FODERO ACCELERA CABLE ASSY TRHOTTLE	GASKABEL GAINE ET CABLE DE GAZ	3 6 9	
04A		00H00930091	R-EMPUÑADURA GAS R-MANOPOLA ACCELERATORE GRIP, THROTTLE	GRIF CAOUT.DE PIGNEE GAZ	1 2 3 4 5 6 7 8 9	
05A		00G02102083	R-CTO MANDO FRENO DT R-COMANDO FRENO FRONT BRAKE LEVER/MASTER CYLIN	REP.-SATZ F. PUMPE R-ENSEM.KIT REPAR. POMPE SE	1 2 3 4 5 6 7 8 9	
06A		00F00902291	MANETA FRENO DELANTERO LEVA FRENO BRAKE LEVER	BREMSHEBEL KOMPL. MANETE DU FREIN AVANT	1 2 3 4 5 6 7 8 9	
07A		00H02100191	R-TAPA DEPOSITO LIQ. FRENO DT. COPERCHIO SERBATOIO LIQUIDO BRAKE FLUID RESERVOIR CAP	BREMSFLUESSIGKEITSBEHAELTE R-COUV.RESER.LIQ.FREIN AVAN	1 2 3 4 5 6 7 8 9	
08A		00H02100861	R-JUNTA TAPA DEP. LIQ. FRENO GUARNIZIONE COPERCHIO BRAKE FLUID RESERVOIR CAP SEAL	BREMSCEKELDICHTUNG R-JOINT COUV.RES.LIQ.FR.AV.	1 2 3 4 5 6 7 8 9	
09A		00014041200	TORNILLO C/AR. CRUZ 4M80X12 VITE COUNTERSUNK PHILIPS SCREW	SCHRAUBE BOULON T.NOYEE	1 2 3 4 5 6 7 8 9	
10A		00000031080	ARANDELA PLANA D8 RONDELLA WASHER	SCHEIBE RONDELLE	1 2 3 4 5 6 7 8 9	

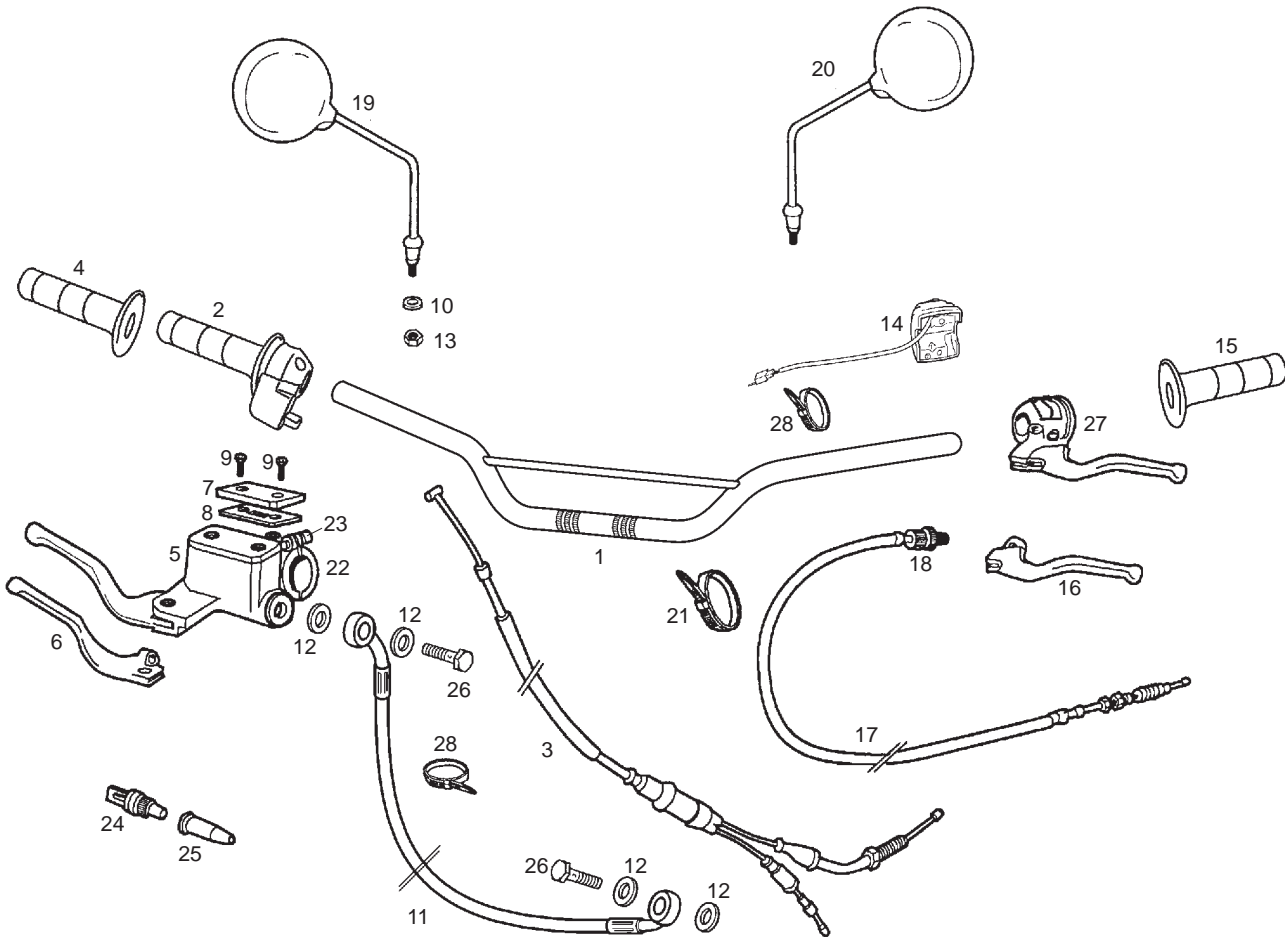

Fig.	Ver.	COD. KOD.	DESCRIPCIÓN DENOMINAZIONE NAME	BEZEICHNUNG DESIGNATION	MOD.	NOTAS NOTES NOTA MITSCHRIFT NOTES
11A		00H00915751	R-TUBO LIQUIDO FRENO DT SUBCOMP.TUBO LIQ.FRE. BRAKE FLUID TUBE	BREMSSSCHLAUCH FLEXIBLE DE FREIN AVANT	1 2 3 4 5 6 7 8 9	
12A		00006321040	ARANDELA JUNTA RADORD RONDELLA WASHER	SCHEIBE RONDELLE	1 2 3 4 5 6 7 8 9	
13A		00000021080	TUERCA DADO NUT	MUTTER ECROU	1 2 3 4 5 6 7 8 9	
14A		00H02305381	CTO.CONMUTADOR LUCES C/CABLE CONMUTATORE LUCI SWITCH	LICHTSCHALTER INVERSEUR AVEC CABLE	1 2 3 4 5 6 7 8 9	
15A		00H00930071	EMPUÑADURA LADO EMBRAGUE R-MANOPIOLA GRIP	GRIF CAOUT.DE PIGNEE GAZ	1 2 3 4 5 6 7 8 9	
16A		00F00910291	R-MANETA EMBRAGUE LEVA FRIZIONE CLUTCH LEVER	KUPPLUNGSHEBEL LEVIER EMBRAYAGE	1 2 3 4 5 6 7 8 9	
17A		00H00917301	CTO. CABLE-FUNDA EMBRAGUE CAVO-GUAINA FRIZIONE CLUTCH COVER AND CAB.SUB.ASSY.	KUPPLUNGSZUG GAINE ET CABLE DIEMBRAYAGE	1 2 3 4 5 6 7 8 9	
18A		00F00920551	R-CTO TENSOR CABLE EMBRAGUE TENSORE CABO CLUTCH CABLE TIGHTENING DEVIC	SHELLE COLLIER FIX ELIERIE	1 2 3 4 5 6 7 8 9	
19A		00H02213671	ESPEJO RETROVISOR DERECHO SPECCHIETO RETROVISO REAR MIRROW	SPIEGEL MIRROIR RETROVISEUR	1 2 3 4 5 6 7 8 9	
20A		00H04608921	ESPEJO RETROVISOR IZQUIERDO SPECCHIETO RETROVISO REAR MIRROW	SPIEGEL MIRROIR RETROVISEUR	1 2 3 4 5 6 7 8 9	
21A		00F00900531	BRIDA 290 X 4,8 FLANGIA UNIONE CAVI BLACK CABLE TIE	KABELBINDER COLLIER	1 2 3 4 5 6 7 8 9	

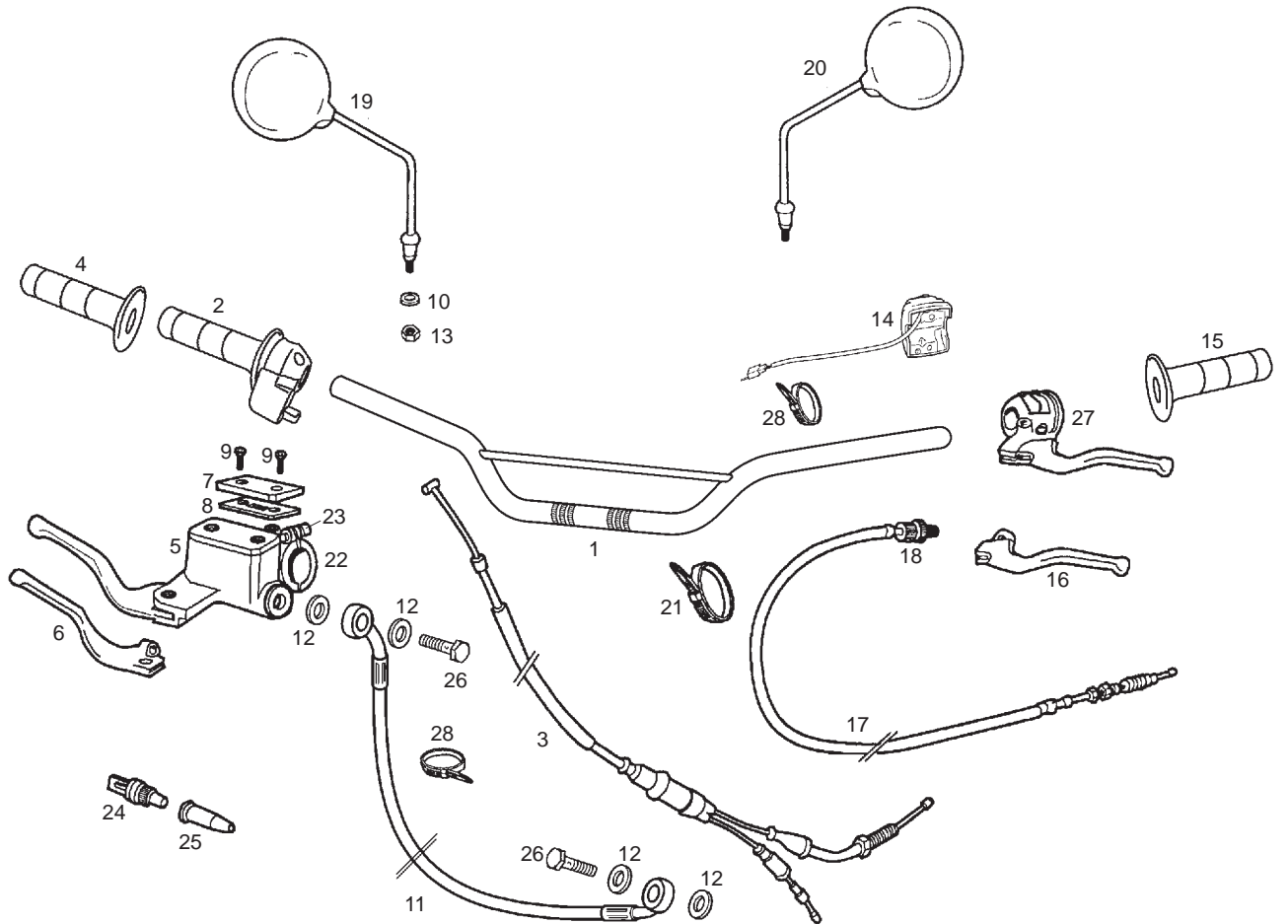
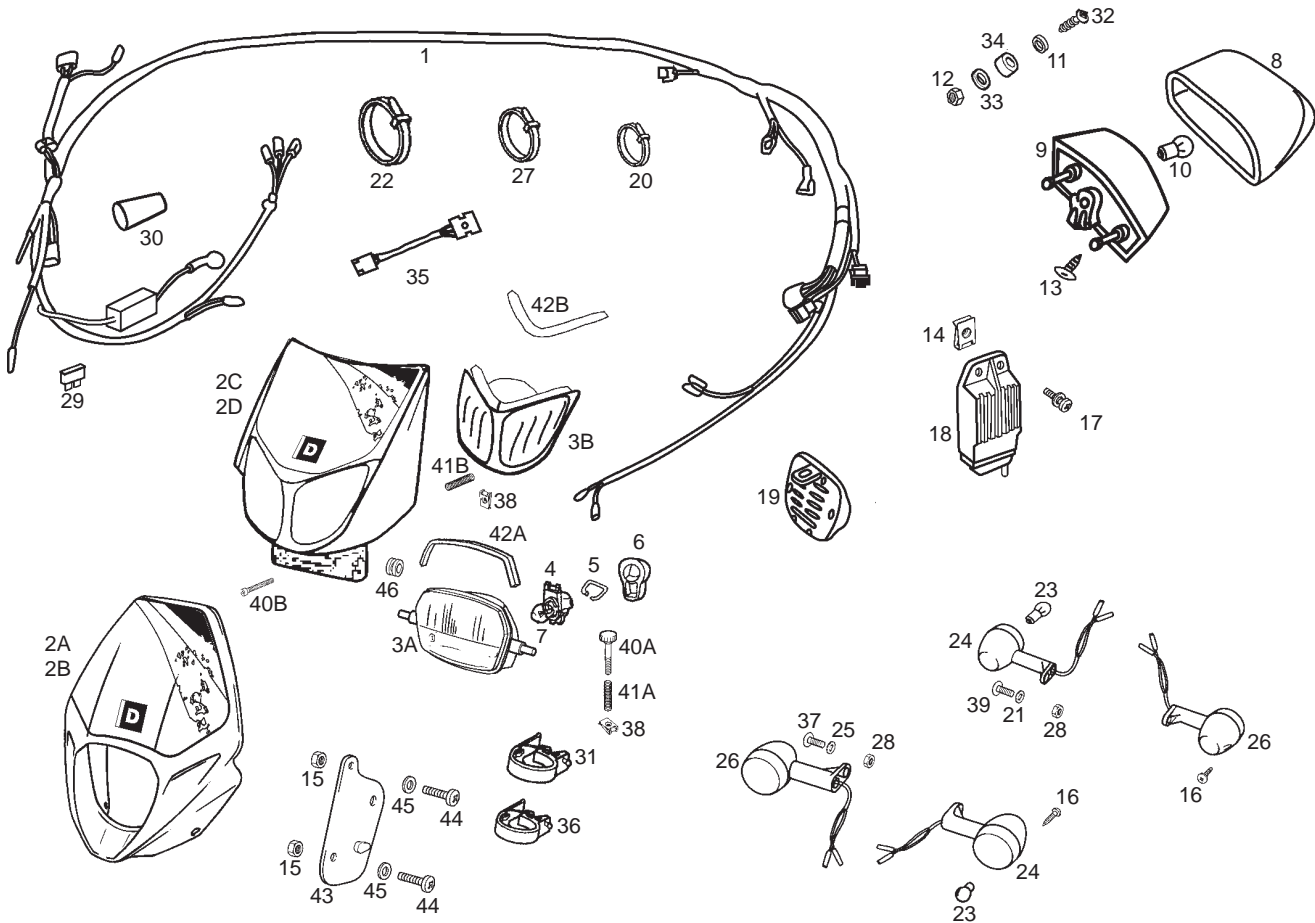

Fig.	Ver.	COD. KOD.	DESCRIPCIÓN DENOMINAZIONE NAME	BEZEICHNUNG DESIGNATION	MOD.	NOTAS NOTES NOTA MITSCHRIFT NOTES
22A		00D02100901	R-BRIDA FIJ. MANDO FRENO DT. CAVALLOTO FISSAGIO POMPA CLAMP	BEF.-SCHELLE ENTRETOISE	1 2 3 4 5 6 7 8 9	
23A		00004061600	TORNILLO C/ALLEN 6M100X16 VITE SCREW	SCHRAUBE VIS	1 2 3 4 5 6 7 8 9	
24A		00D01000701	INTERRUPTOR MANDO STOP. INTERRUPTORE STOP SWITCH, STOP LIGHT	STOPCHALTER VO. INTERRUPTEUR COMMANDE STOP	1 2 3 4 5 6 7 8 9	
25A		00005010760	CAPUCHON INTERRUPTOR STOP CAPPuccio INTERRUPTORE STOP NE RUBBER COVER, STOP LIGHT SWITCH	GUMMISCHUTZ STOPLICHTSCHAL CAPUCHON	1 2 3 4 5 6 7 8 9	
26A		00006309260	RACORD TUBO HIDRAULICO RACCORDO TUBO IDRAULICO HYDRAULIC TUBE CONNECTOR	STUTZEN HIDRAULIKLEITUNG RACCORD TUYAU HYDRAULIQUE	1 2 3 4 5 6 7 8 9	
27A		00H02105611	CTO. PORTAMANETA IZQUIERDO PORTAMANOPOLA SINIST LEFT LEVER BRACKET	BREMSHEBEL LINKS KOMPLETT ENS. PORTE-MANETTE GAUCHE	1 2 3 4 5 6 7 8 9	
28A		00A00900531	BRIDA 140 X 3,6 FLANGIA UNIONE CAVI BLACK CABLE TIE	KABELBINDER COLLIER	1 2 3 4 5 6 7 8 9	



**PIEZAS CON CALCAS
PARTS WITH DECALS**

Fig.	Ver.	COD. KOD.	DESCRIPCIÓN DENOMINAZIONE NAME	BEZEICHNUNG DESIGNATION	MOD.	NOTAS NOTES NOTA MITSCHRIFT NOTES
01A		00H01046301	CTO.INSTALACION ELECTRICA IMPIANTO ELETTRICO ELECTRICAL INSTALATIONS ASSY.	KOBELBAUM FAISCEAU ELECTRIQUE	1 2 3 4 5 6 7 8 9	
02A		86358000WB0	CARCASA FARO CARCASA FARO HEADLIGHT CUSING SUB-ASSEMBLY	SCHEINWERFERVERKLEIDUNG PLAQUE PHARE	1 2 3	
02B		86358200WB0	CARCASA FARO FRANCE CARCASA FARO HEADLIGHT CUSING SUB-ASSEMBLY	SCHEINWERFERVERKLEIDUNG PLAQUE PHARE	1 2	ONLY FRANCE AUSTRIA
02C		86358100WB0	CARCASA FARO CARCASA FARO HEADLIGHT CUSING SUB-ASSEMBLY	SCHEINWERFERVERKLEIDUNG PLAQUE PHARE	4 5 6	
02D		86358300WB0	CARCASA FARO FRANCE CARCASA FARO HEADLIGHT CUSING SUB-ASSEMBLY	SCHEINWERFERVERKLEIDUNG PLAQUE PHARE	4 5	ONLY FRANCE AUSTRIA
02E		86358100WN0	CARCASA FARO CARCASA FARO HEADLIGHT CUSING SUB-ASSEMBLY	SCHEINWERFERVERKLEIDUNG PLAQUE PHARE	7 8 9	
02F		86389900WN0	CARCASA FARO FRANCE CARCASA FARO HEADLIGHT CUSING SUB-ASSEMBLY	SCHEINWERFERVERKLEIDUNG PLAQUE PHARE	7 8	ONLY FRANCE AUSTRIA
03A		00H01015011	CTO FARO DELANTERO FARO ANTERIORE HEADLIGHT LENS SUB-ASSEMBLY	SCHEINWERFER OPTIQUE COMPLETE	1 2 3 4 5 6 7 8 9	
03B		00H01013011	CTO FARO DELANTERO FARO ANTERIORE HEADLIGHT LENS SUB-ASSEMBLY	SCHEINWERFER OPTIQUE COMPLETE	1 2 4 5 7 8	ONLY FRANCE AUSTRIA
04A		00003710110	R-PORTALAMPARAS PORTA-LAMPADE BULB HOLDER	LAMPENHALTER R-PORTE-LAMPES	1 2 3 4 5 6 7 8 9	

**PIEZAS CON CALCAS
PARTS WITH DECALS**

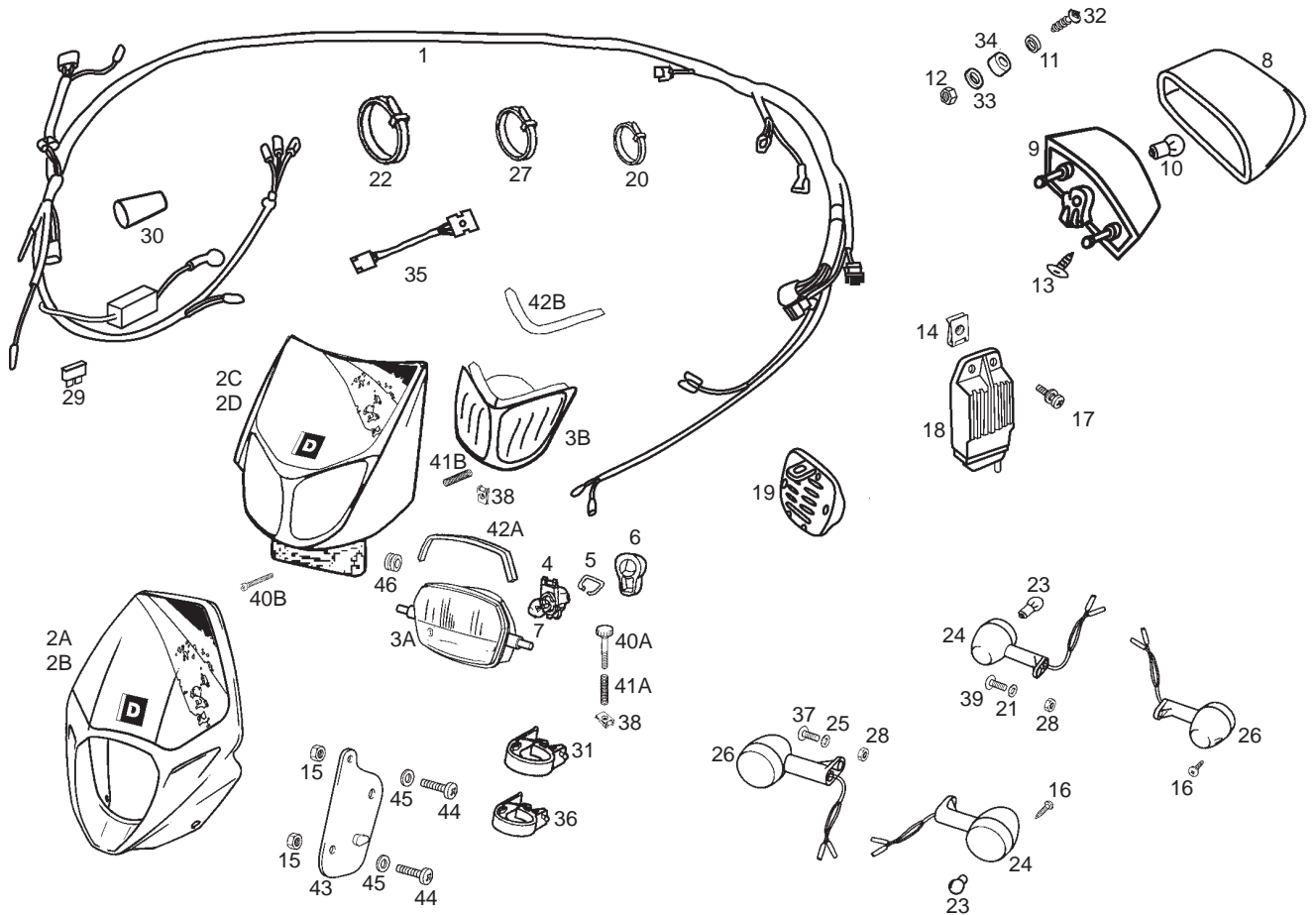
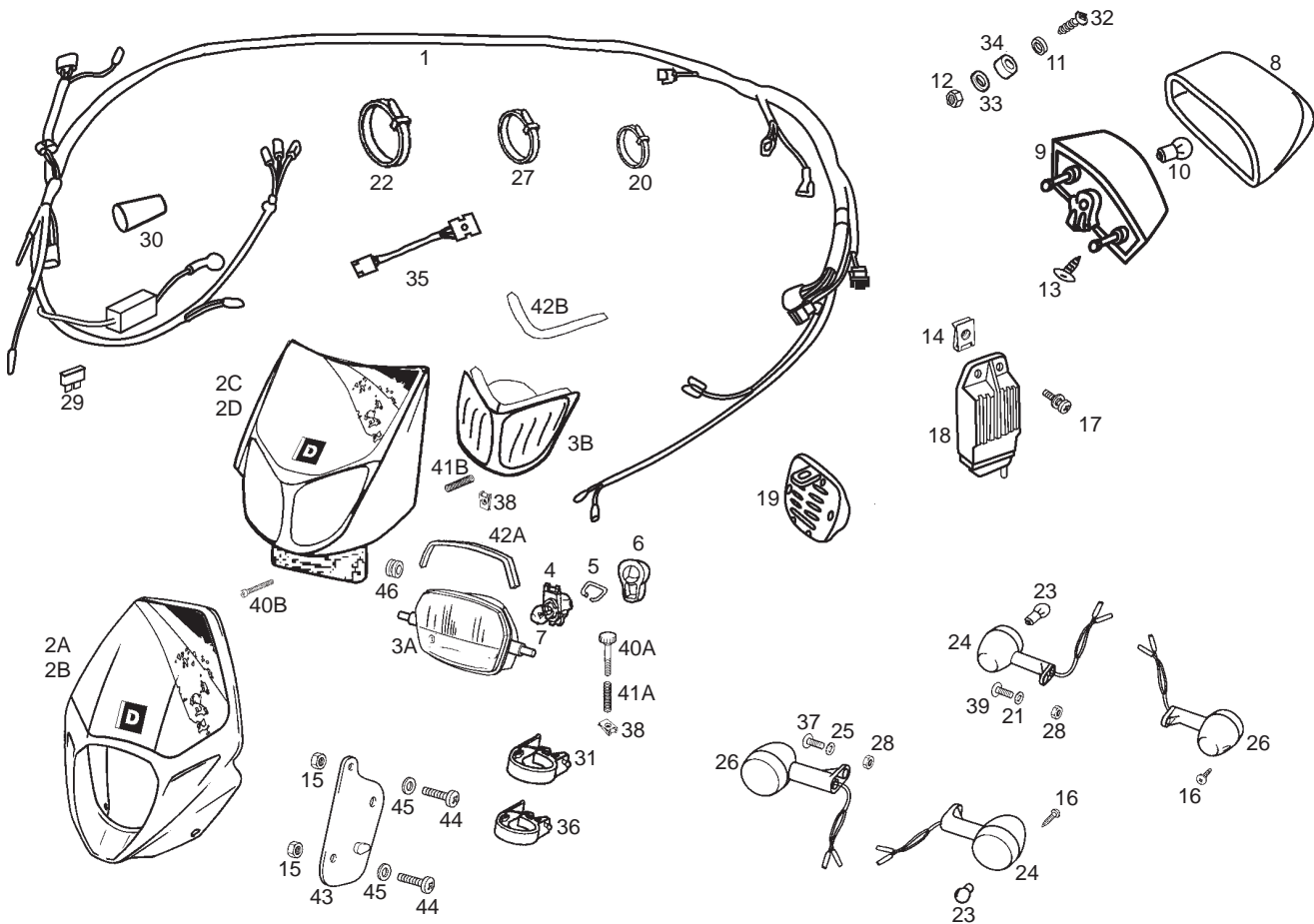

Fig.	Ver.	COD. KOD.	DESCRIPCIÓN DENOMINAZIONE NAME	BEZEICHNUNG DESIGNATION	MOD.	NOTAS NOTES NOTA MITSCHRIFT
05A		00003710120	R-MUELLE PORTLAMPARAS R- MOLLA PORTALAMPADAE BULB HOLDER SPRING	FEDER F. LAMPENHALTER R-RESSORT PORTE-LAMPES	1 2 3 4 5 6 7 8 9	
06A		00H05703141	R-PROTECTOR PORTALAMPARAS R-PROTEZIONE PORTA LAMPADA FA HEADLAMP BULB HOLDER PROTC	LAMPENDECKEL R-PROT.PORTE-LAMPES	1 2 3 4 5 6 7 8 9	
07A		00H01000131	LAMPARA FARO 12V 35W/35W LAMPADA FARO HEADLIGHT BULB	SCHEINWERFERLAMPE TUBE PHARE	1 2 3 4 5 6 7 8 9	
08A		00H01002341	R-CRISTAL PILOTO VETRO SPIA/STOP LENS, TAILLIGHT	RUCK LIGHTCELLONES CABOCHON DE FEU ARRIERE	1 2 3 4 5 6 7 8 9	
09A		00H01006321	CTO.FARO PILOTO FANALINO POSTERIORE TAIL LIGHT ASSY	RUCKLIGHT FEU ARRIERE	1 2 3 4 5 6 7 8 9	
10A		00H01000371	LAMP.PILOTO-STOP.12V.21/5W. LAMPADA FANALINO POSTERIORE BULB, TAILLIGHT/STOP	BIRNE BREMSLIGHT LAMPE-TEMOIN-STOP	1 2 3 4 5 6 7 8 9	
11A		00H03800722	ARANDELA TOPE MUELLE EMBRAGUE RONDELLA WASHER	SCHEIBE RONDELLE	1 2 3 4 5 6 7 8 9	
12A		00000023051	TUERCA AUTOBLOCANTE 5M80 DADO NUT	MUTTER ECROU	1 2 3 4 5 6 7 8 9	
13A		00G01001571	R-TORNILLO FIJ.FARO PILOTO PREDATOR VITE SCREW	SCHRAUBE VIS	1 2 3 4 5 6 7 8 9	
14A		00D01501371	TUERCA FIJACION D6 DADO NUT	MUTTER ECROU	1 2 3 4 5 6 7 8 9	



**PIEZAS CON CALCAS
PARTS WITH DECALS**

Fig.	Ver.	COD. KOD.	DESCRIPCIÓN DENOMINAZIONE NAME	BEZEICHNUNG DESIGNATION	MOD.	NOTAS NOTES NOTA MITSCHRIFT NOTES
15A		00026005000	TUERCA EXAG C/BRIDA 5M80 DADO NUT	MUTTER ECROU	1 2 3 4 5 6 7 8 9	
16A		00011021300	TORNILLO AUTR.C/CRUZ.2,9X13 VITE SCREW	SCHRAUBE VIS	1 2 3 4 5 6 7 8 9	
17A		00D05900081	SCTO TORNILLO 6M100X16 VITE SCREW	SCHRAUBE VIS	1 2 3 4 5 6 7 8 9	
18A		00H01008841	REGULADOR AC/DC REGOLATORE TENSIONE REGULATOR	SPANNUNGSREGLER REGULATEUR AC/DC	1 2 3 4 5 6 7 8 9	
19A		00H01005311	CTO. CLAXON CLACSON HORN ASSEMBLY	HUPE KLAXON COMPLET	1 2 3 4 5 6 7 8 9	
20A		00A00900531	BRIDA 140 X 3,6 FLANGIA UNIONE CAVI BLACK CABLE TIE	KABELBINDER COLLIER	1 2 3 4 5 6 7 8 9	
21A		00031106000	ARANDELA PLANA D6 RONDELLA WASHER	SCHEIBE RONDELLE	1 2 3 4 5 6 7 8 9	
22A		00F00900531	BRIDA 290 X 4,8 FLANGIA UNIONE CAVI BLACK CABLE TIE	KABELBINDER COLLIER	1 2 3 4 5 6 7 8 9	
23A		0000A517011	BOMBILLA INTERMITENTES LAMPADA INDICATOR LIGHT BULB	BLINKLICHTLAMPE TUBE PHARES CLIGNOTANTS	1 2 3 4 5 6 7 8 9	
24A		00H01703301	CTO.FARO INTTE.TR.DR.ROUND INDIC.DIREZIONE TURN SIGNAL LIGHT REAR RH	BLINKR HINTEN GLIGNOTEURS AR. DROITE	1 2 3 4 5 6 7 8 9	

**PIEZAS CON CALCAS
PARTS WITH DECALS**

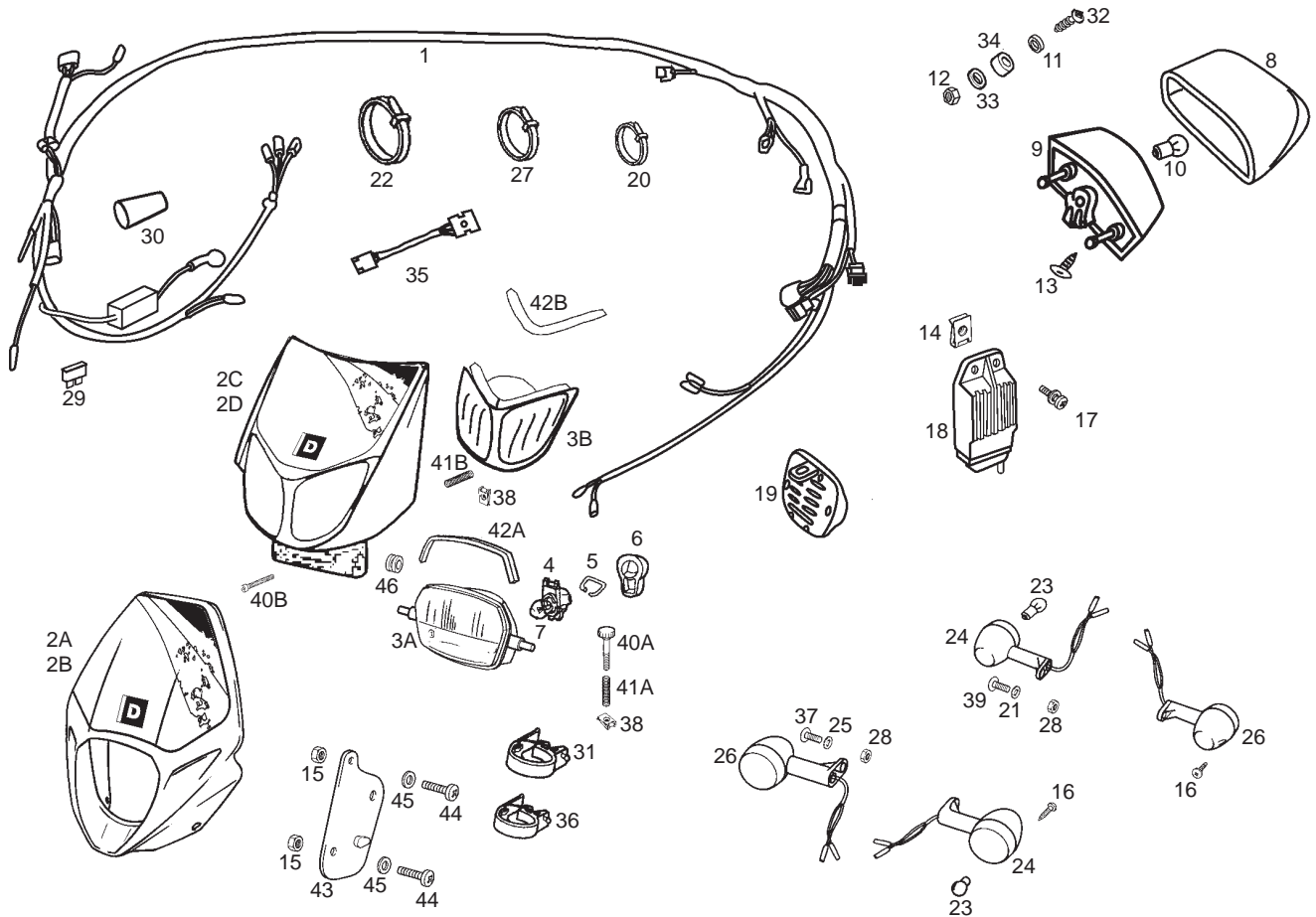
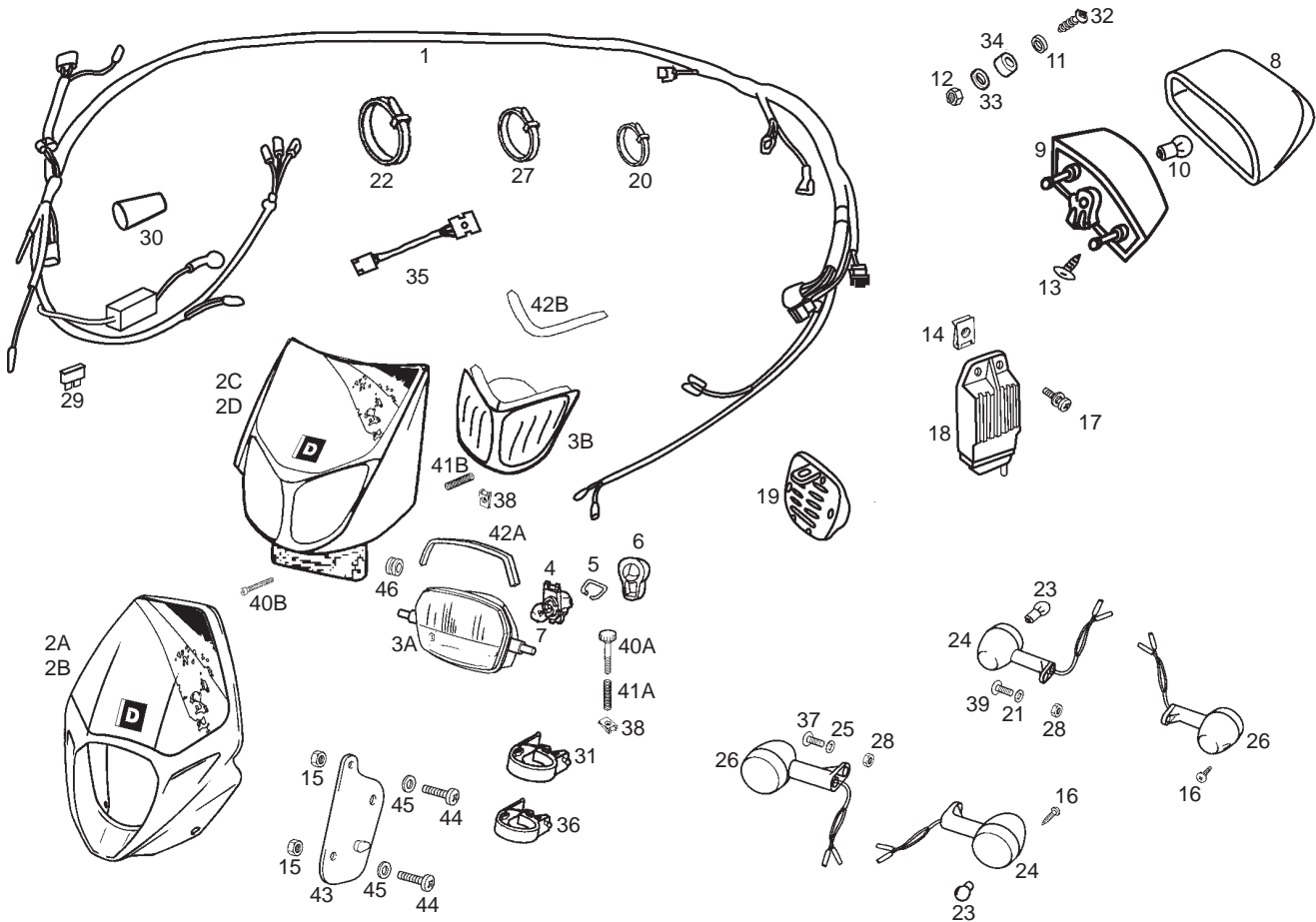

Fig.	Ver.	COD. KOD.	DESCRIPCIÓN DENOMINAZIONE NAME	BEZEICHNUNG DESIGNATION	MOD.	NOTAS NOTES NOTA MITSCHRIFT NOTES
25A		00031106000	ARANDELA PLANA D6 RONDELLA WASHER	SCHEIBE ROND.PLATE MECANISEE	1 2 3 4 5 6 7 8 9	
26A		00H01703391	CTO.FARO INTTE.TR.IZQ.ROUND COMP.INDIC.DIREZIONE TURN SIGNAL LIGHT REAR LEFT	BLINKR HINTEN GLIGNOTEURS AR. GAUCHE	1 2 3 4 5 6 7 8 9	
27A		00D00900531	BRIDA 200 X 3,6 FLANGIA UNIONE CAVI BLACK CABLE TIE	KABELBINDER COLLIER	1 2 3 4 5 6 7 8 9	
28A		00000023060	TUERCA AUTOBLOCANTE 6M100 DADO NUT	MUTTER ECROU	1 2 3 4 5 6 7 8 9	
29A		00H01001911	FUSIBLE 7,5 AMP FUSIBILE FUSE	FUSE FUSIBLE	1 2 3 4 5 6 7 8 9	
30A		00H02300961	PROTECTOR INSTALACION PROTEZIONE WIRING HARNESS CONNECTOR	WIRING HARNESS CONNECTOR PROTE PROTECTION CONNEXIONS INSTALLA	1 2 3 4 5 6 7 8 9	
31A		00H04607841	BRIDA FIJACION CARCASA FARO FLANGIA CLAMP	BEF.-SCHELLE ENTRETOISE	1 2 3 4 5 6 7 8 9	
31B		00H04608841	BRIDA FIJ. SUP.CARCASA FARO FLANGIA CLAMP	BEF.-SCHELLE ENTRETOISE	1 2 4 5 7 8	ONLY FRANCE AUSTRIA
32A		00004053500	TORNILLO C/ALLEN 5 X 35 VITE BOLT	INBUSSCHRAUBE VIS	1 2 3 4 5 6 7 8 9	
33A		00H01002821	CASQUILLO GHIERA BEARING	LAGER COUSSINET	1 2 3 4 5 6 7 8 9	



**PIEZAS CON CALCAS
PARTS WITH DECALS**

Fig.	Ver.	COD. KOD.	DESCRIPCIÓN DENOMINAZIONE NAME	BEZEICHNUNG DESIGNATION	MOD.	NOTAS NOTES NOTA MITSCHRIFT NOTES
34A		00H06800461	SILENTB.FIJ.SOPTE.CARENADO SILENTBLOCK FISS.SUPORTO FAIRING MOUNTING BRACKET SECUR	SILENTBLOCK SILENTBLOC	1 2 3 4 5 6 7 8 9	
35A		00H05700481	CTO.TEMPORIZADOR CHECK IND. TEMPORIZZATORE CHECK INP. TIMER CHECK INDICATOR	ZEITSCHALTER FAISCEAU COMPTEUR	1 2 3 4 5 6 7 8 9	
36A		00H04607841	BRIDA FIJACION CARCASA FARO FLANGIA CLAMP	BEF.-SCHELLE ENTRETOISE	1 2 3 4 5 6 7 8 9	
37A		00008063000	TORNILLO C/RED ALLEN 6M100X30 VITE SCREW	SCHRAUBE VIS	1 2 3 4 5 6 7 8 9	
38A		00G04401462	TUERCA FIJACION D5 DADO NUT	MUTTER ECROU	1 2 3 4 5 6 7 8 9	
39A		00008061500	TORNILLO C/RED ALLEN 6M100X16 VITE SCREW	SCHRAUBE VIS	1 2 3 4 5 6 7 8 9	
40A		00012053000	TORNILLO REGULACION VITE SCREW	SCHRAUBE VIS	1 2 3 4 5 6 7 8 9	
40B		00012045000	TORNILLO REGULACION VITE SCREW	SCHRAUBE VIS	1 2 4 5 7 8	ONLY FRANCE AUSTRIA
41A		00H02305501	MUELLE REGULACION MOLLA FARO ANTERIORE FRONT HEAD LIGHT SPRING	SCHEINWERFER-FEDER RESSORT PHARE AVANT	1 2 3 4 5 6 7 8 9	
41B		00H02304501	MUELLE REGULACION MOLLA FARO ANTERIORE FRONT HEAD LIGHT SPRING	SCHEINWERFER-FEDER RESSORT PHARE AVANT	1 2 4 5 7 8	ONLY FRANCE AUSTRIA

**PIEZAS CON CALCAS
PARTS WITH DECALS**

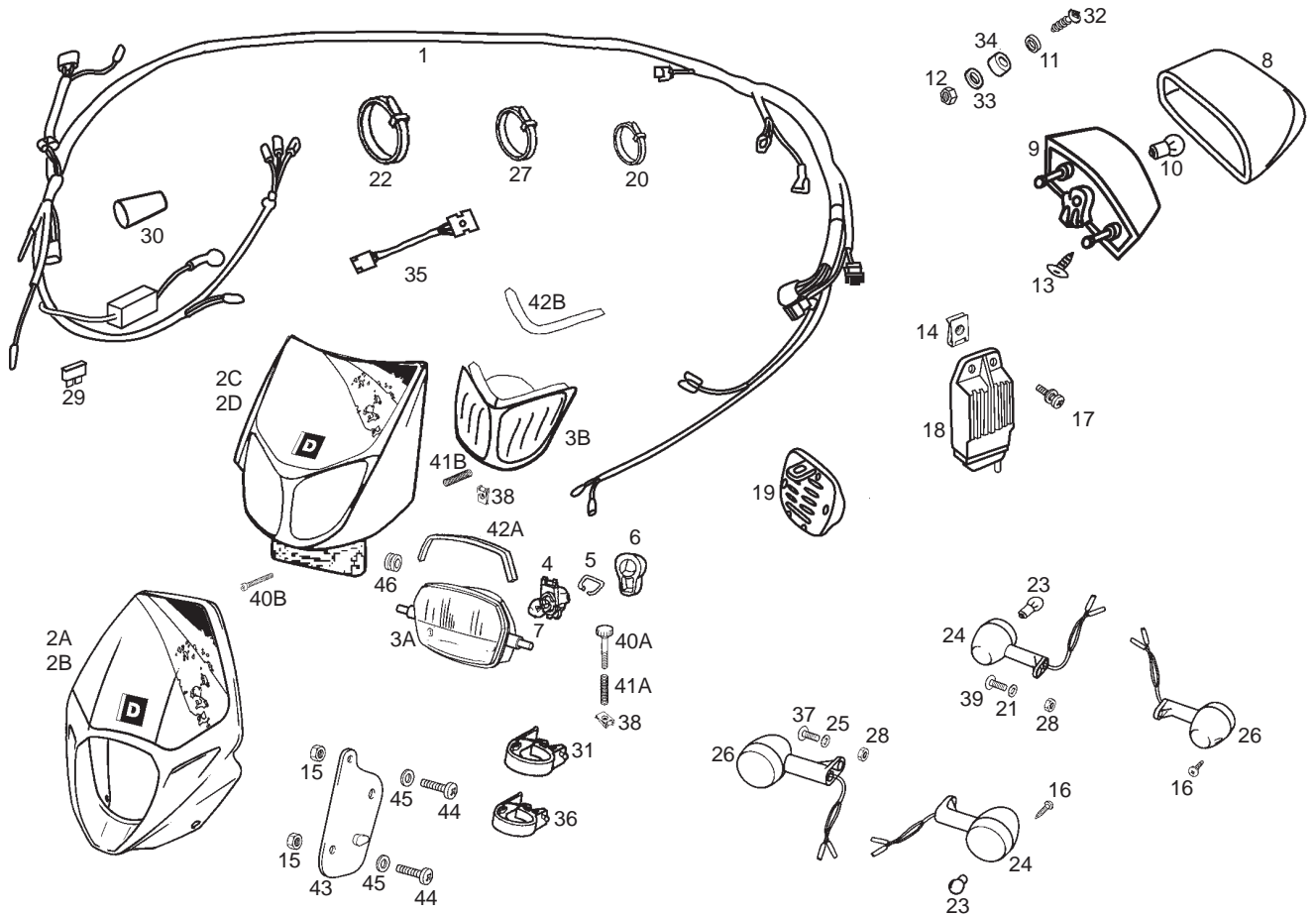

Fig.	Ver.	COD. KOD.	DESCRIPCIÓN DENOMINAZIONE NAME	BEZEICHNUNG DESIGNATION	MOD.	NOTAS NOTES NOTA MITSCHRIFT NOTES
42A		00H05701101	TOPE FARO FERMO FARO HEADLIGHT STOP	ANSCHLAG SCHEINWERFER BUTEE PHARE	1 2 3 4 5 6 7 8 9	
42B		00H05700101	TOPE FARO FERMO FARO HEADLIGHT STOP	ANSCHLAG SCHEINWERFER BUTEE PHARE	1 2 4 5 7 8	ONLY FRANCE AUSTRIA
43A		00H01502741	SOPORTE CARCASA FARO SUPPORTO CARC. HEADLIGHT CUSING SUPPORT	HALTERUNG SUPPORT	1 2 3 4 5 6 7 8 9	
44A		00012051200	TORNILLO C/R.CRUZ.5M80X12 VITE SCREW	SCHRAUBE VIS	1 2 3 4 5 6 7 8 9	
45A		00000031050	ARANDELA PLANA D5 RONDELLA WASHER	SCHEIBE RONDELLE	1 2 3 4 5 6 7 8 9	
46A		00H05701061	PASACABLES PORTACAVI IST. FARAFANGO POST. GROMMET	GUMMI CAOUTCHOUC PASSE-CABLE	1 2 3 4 5 6 7 8 9	

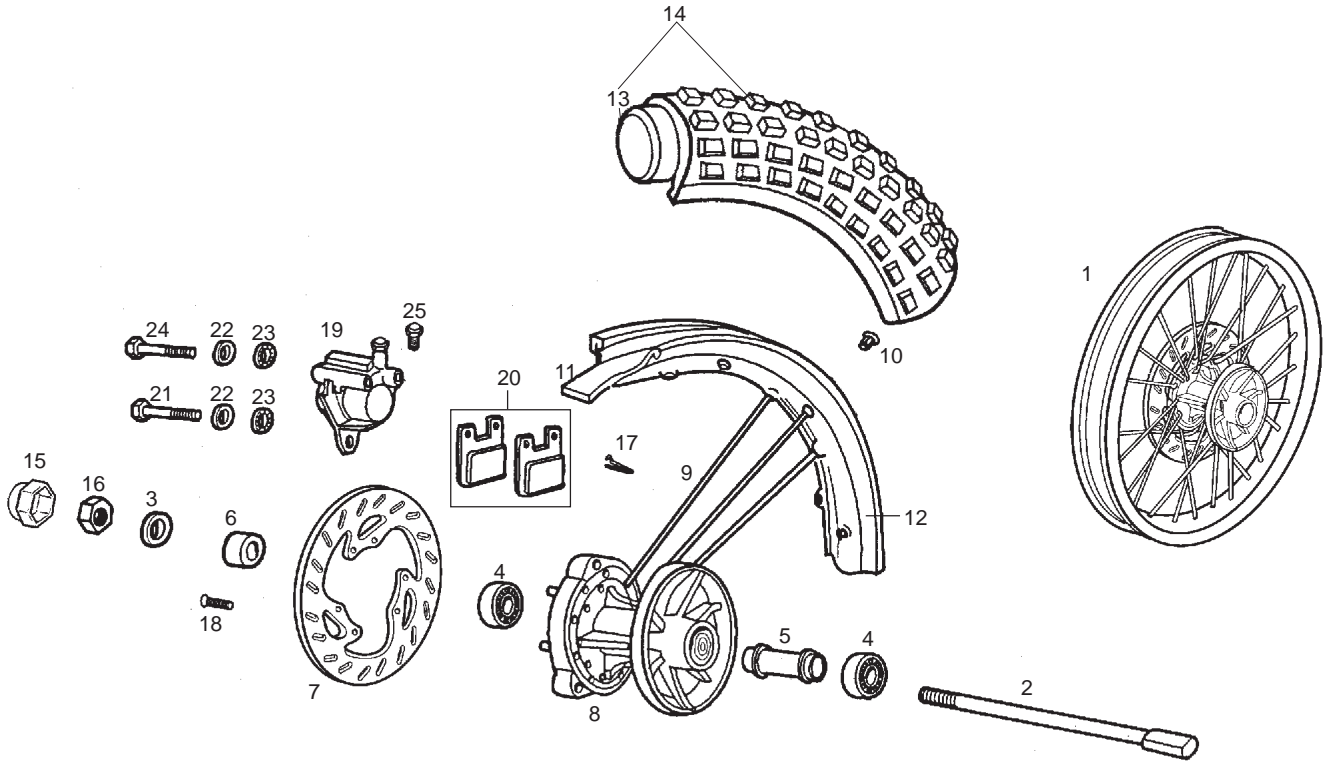

Fig.	Ver.	COD. KOD.	DESCRIPCIÓN DENOMINAZIONE NAME	BEZEICHNUNG DESIGNATION	MOD.	NOTAS NOTES NOTA MITSCHRIFT NOTES
01A		00H04713082	R-CTO RUEDA DT C/DISCO R-COMPL. RUOTA C/DISCO FRONT WHEEL W/DISC	VORDERRAD M/BREMSSCHEIBE ROUE AVEC DISQUE	1 2 3 4 5 6 7 8 9	
02A		00H01203272	EJE RUEDA DTRA. ASSE RUOTA ANTERIORE AXLE FRONT WHEEL	VORDERRADACHSE AXE DE ROUE AV.	1 2 3 4 5 6 7 8 9	
03A		00003112322	ARANDELA EJE RUEDA. RONDELLA ASSE RUOTA FRONT WHEEL AXLE WASHER	SHEIBE RADACHSE RONDELLE AXE ROUE	1 2 3 4 5 6 7 8 9	
04A		00058120100	COJINETE 12.32.10 CUSCINETTO BEARING	LAGER PALIER	1 2 3 4 5 6 7 8 9	
05A		00D01300091	SEPARADOR COJINETES SEPARATORE CUSCINETTI SPACER	DISTANZHULSE ENTRETOISE	1 2 3 4 5 6 7 8 9	
06A		00008213182	CASQUILLO LADO PLATO CHIERA LATO PIATTO SIDEFLAGE SLEEVE	DISTANZHULSE ENTRETOISE	1 2 3 4 5 6 7 8 9	
07A		00H01209021	DISCO FRENO DELANTERO DISCO FRENO ANTERIORE FRONT BRAKE DISC	SCHEIBE NBREMSE VORN DISQUE FREIN AVANT	1 2 3 4 5 6 7 8 9	
08A		00H01205711	CTO. CARRETE DTRO. MOZZO ANT. FRONT HUB ASSY	RADNABE MOYEU	1 2 3 4 5 6 7 8 9	
09A		00H01206061	RADIO RUEDA DT RAGGIO RUOTA ANT. WHEEL ARM.	SPEICHE RAYON DE ROUE	1 2 3 4 5 6 7 8 9	
10A		00002212070	TUERCA RADIO. DADO NUT	MUTTER ECROU	1 2 3 4 5 6 7 8 9	
11A		00D01201091	PROTECTOR CAMARA PROTETTORE CAMERA RUOTA RIM STRIP	FELGELBAND PROTECTEUR DE CHAMBRE A AIR	1 2 3 4 5 6 7 8 9	

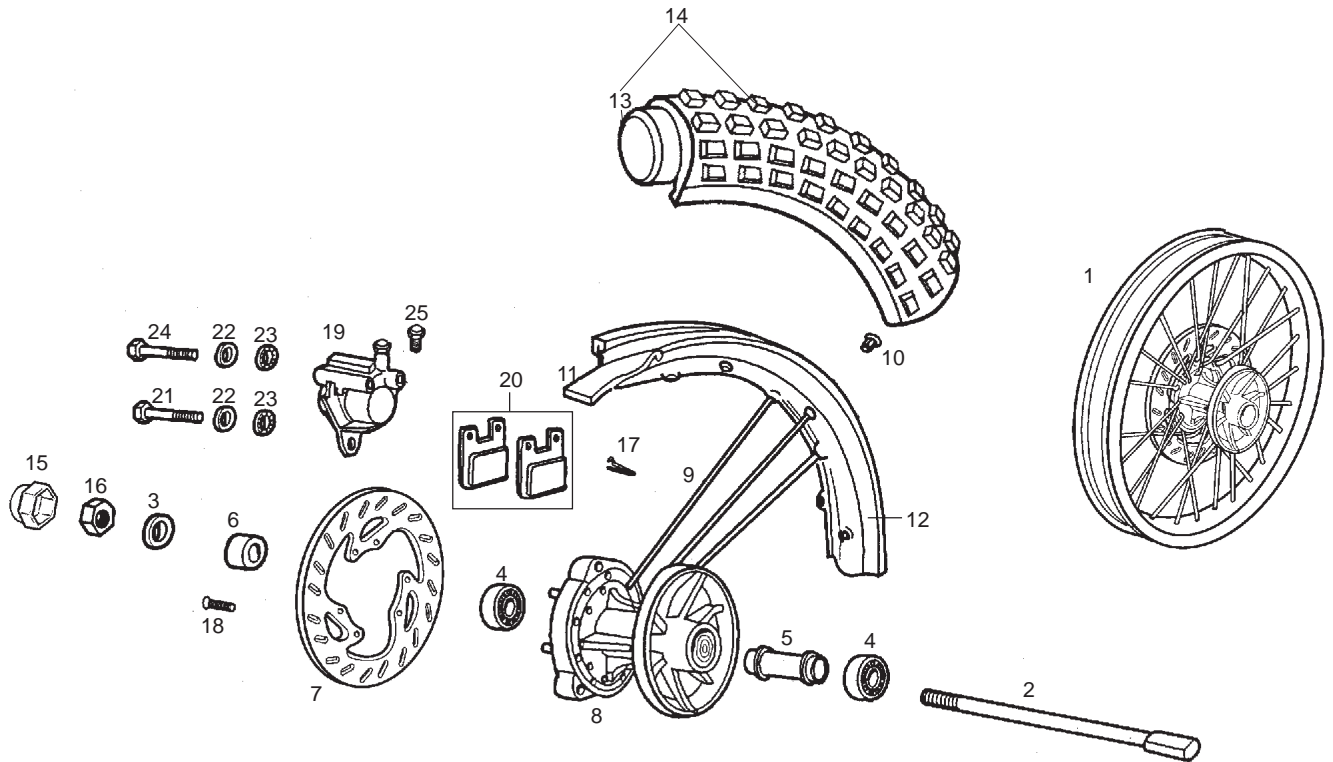

Fig.	Ver.	COD. KOD.	DESCRIPCIÓN DENOMINAZIONE NAME	BEZEICHNUNG DESIGNATION	MOD.	NOTAS NOTES NOTA MITSCHRIFT NOTES
12A		00H01212081	R-LLANTA DT 1,6X21" CERCHIONE RUOTA ANT. FRONT WHEEL RIM	VORDERRADFELGE JANTE AV.	1 2 3 4 5 6 7 8 9	
13A		00H01206101	CAMARA CAMERA DIARIA FRONT TUBE	SCHLAUCH VORNE CHAMBRE A AIR	1 2 3 4 5 6 7 8 9	
14A		00H01208111	CTO. CUBIERTA DT 21" COPERTORE ANT. FRONT CASING	REIFEN BORN PNEU AV.	1 2 3 4 5 6 7 8 9	
15A		00H01202331	PROTECTOR TUERCA DADO NUT	MUTTER ECROU	1 2 3 4 5 6 7 8 9	
16A		00232120032	TUERCA EXAGONAL 12M150 DADO NUT	MUTTER ECROU	1 2 3 4 5 6 7 8 9	
17A		00H01301831	MUELLE FIJ. PASTILLA FRENO MOLLA FISSAGGIO PASTIGLIA FREN REAR BRAKE PAD SECUR SPRING	FEDER RESSORT FIXATION PLAQUETTE	1 2 3 4 5 6 7 8 9	
18A		00H02402282	TORNILLO FIJ.DISCO FRENO VITE SCREW	SCHRAUBE VIS	1 2 3 4 5 6 7 8 9	
19A		00H01202193	R-CTO PINZA FRENO DT PINZA LEFT-HAND FRONT CLIP ASSY	BREMSZANGE ENS.ETRIER DE FREIN	1 2 3 4 5 6 7 8 9	
20A		00G04700141	JUEGO PASTILLAS DE FRENO CONG. PASTIGLIE FRENO SET OF BRAKE PADS	DIE GESAMTHEIT BREMSBACKEN ENS. PLAQUETTE DE FREIN	1 2 3 4 5 6 7 8 9	
21A		00022083021	TORNILLO 8M125X30 VITE SCREW	SCHRAUBE VIS	1 2 3 4 5 6 7 8 9	
22A		00402080001	ARANDELA D8 RONDELLA WASHER	SCHEIBE RONDELLE	1 2 3 4 5 6 7 8 9	

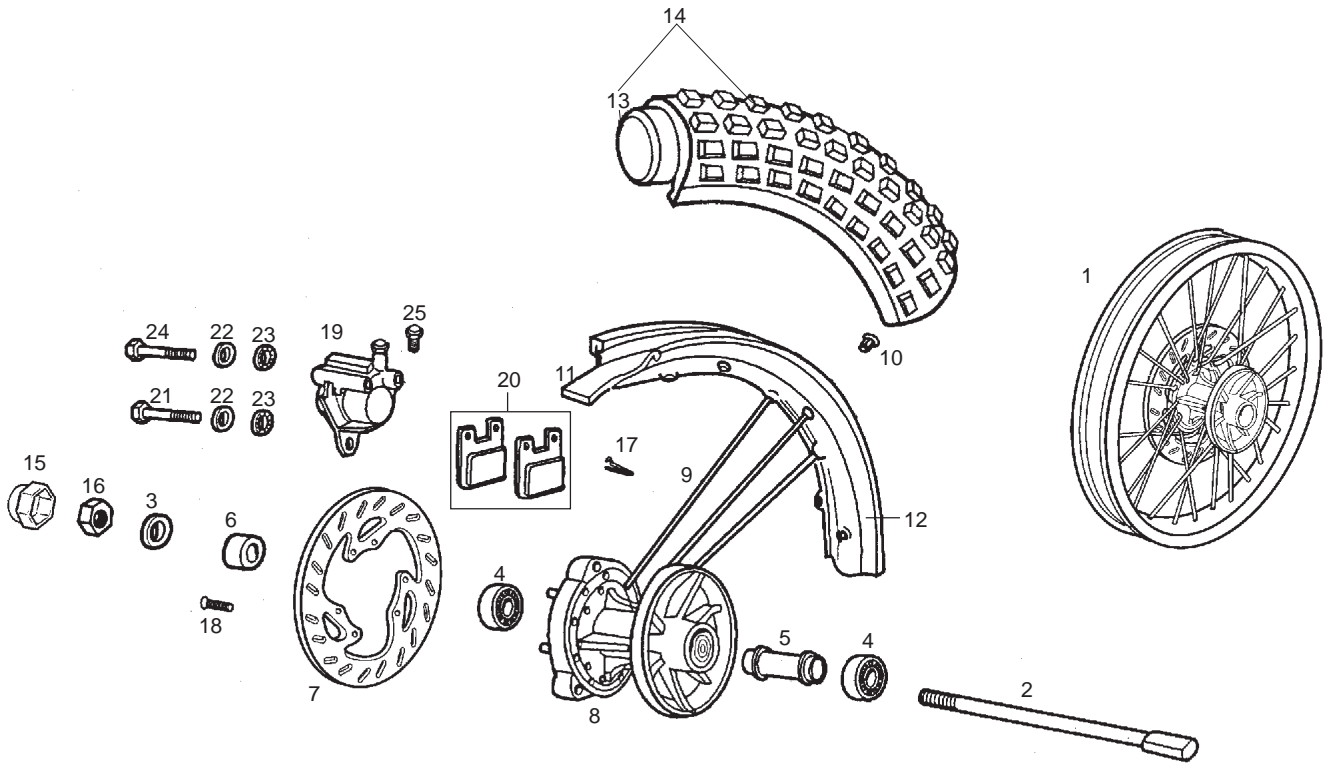

Fig.	Ver.	COD. KOD.	DESCRIPCIÓN DENOMINAZIONE NAME	BEZEICHNUNG DESIGNATION	MOD.	NOTAS NOTES NOTA MITSCHRIFT NOTES
23A		00034000802	ARANDELA ESTRELL.INT.D8 RONDELLA WASHER	SCHEIBE RONDELLE	1 2 3 4 5 6 7 8 9	
24A		00031086022	TORNILLO C/EX. 8M125X60 VITE SCREW	SCHRAUBE VIS	1 2 3 4 5 6 7 8 9	
25A		00F04700121	R-CTO. PURGADOR PINZA FRENO DT. R-SPURGO FRONT BRAKE BLEED CLIP ASSY	ABLASSHAHN R-ENS.PURGEUR PINCE FREIN A	1 2 3 4 5 6 7 8 9	

**RUEDA SIN DISCO Y SIN PLATO
WHEEL WITHOUT DISC AND DRIVE PLATE**

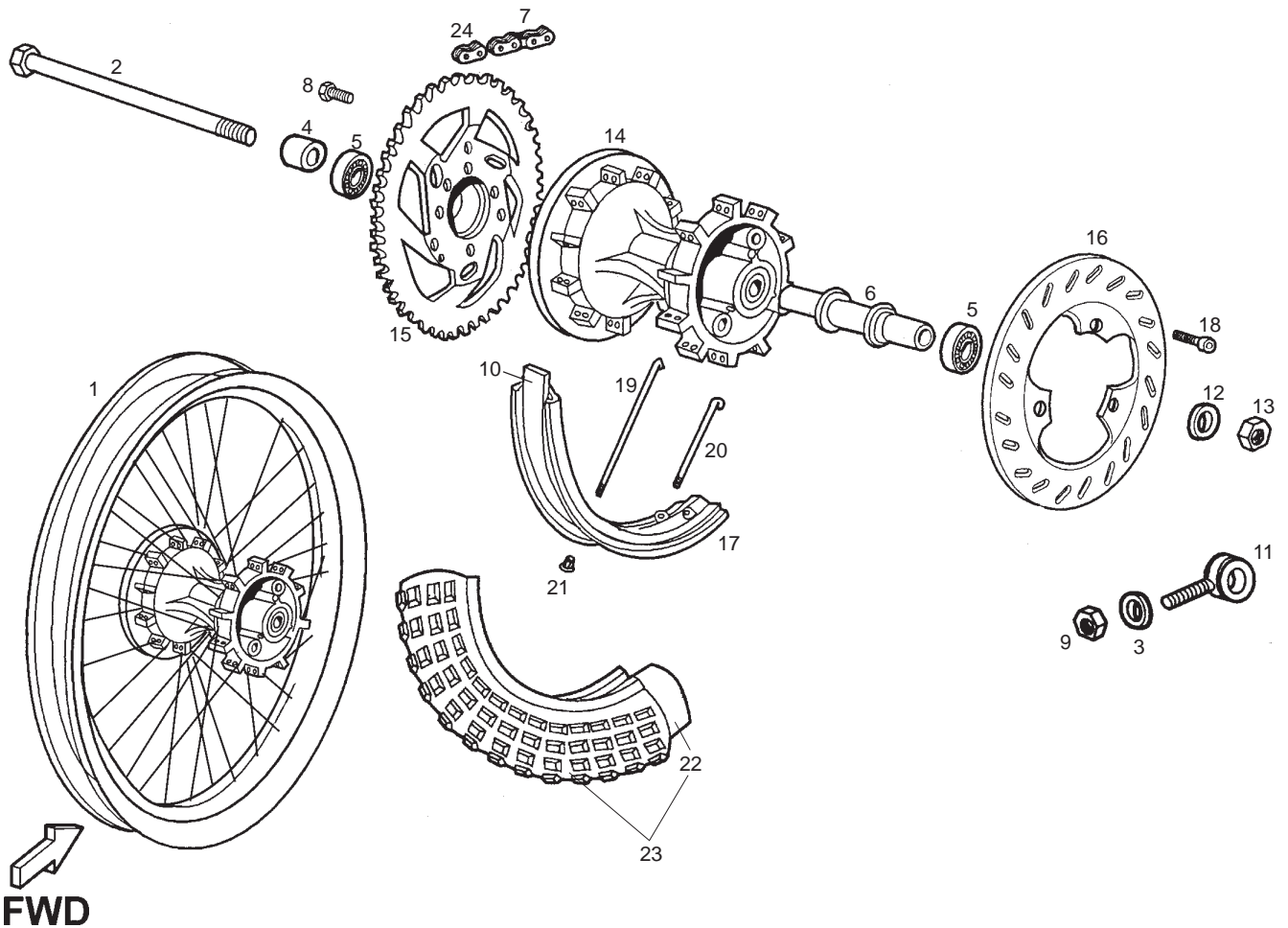
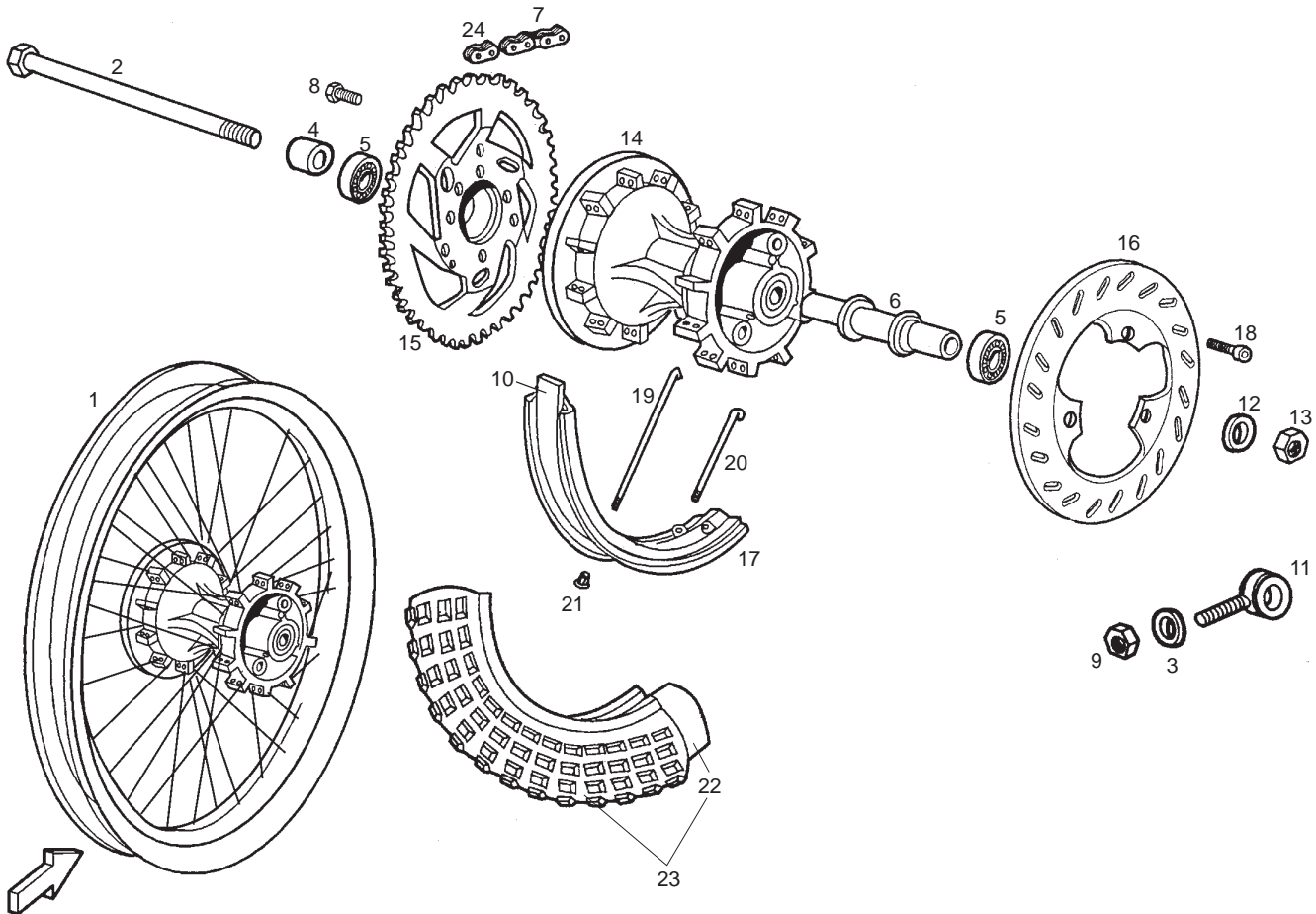

Fig.	Ver.	COD. KOD.	DESCRIPCIÓN DENOMINAZIONE NAME	BEZEICHNUNG DESIGNATION	MOD.	NOTAS NOTES NOTA MITSCHRIFT NOTES
01A		00H02404331	R-CTO LLANTA TR.C/CARR 2,15X18 CERCHIONE CON MOZZO REAR RIM WITH HUB	HINTERRAD MIT RADNABE ROUE ARRIERE AVEC MOYEU	1 2 3 4 5 6 7 8 9	
02A		00H01304202	CTO. EJE RDA. TRAS. SUBASSE RUOTA POSTER REAR WHEEL AXLE SUB-ASSEMBLY G	HINTERRADACHSE AXE ROUE ARRIERE	1 2 3 4 5 6 7 8 9	
03A		00402060001	ARANDELA D6 RONDELLA WASHER	SCHEIBE RONDELLE	1 2 3 4 5 6 7 8 9	
04A		00001113192	CASQUILLO GRUESO LADO PLATO GHIERA LATO PIATTO SPACER	DISTANZHULSE ENTRETOISE	1 2 3 4 5 6 7 8 9	
05A		00058120100	COJINETE 12.32.10 CUSCINETTO BEARING	LAGER PALIER	1 2 3 4 5 6 7 8 9	
06A		00H01304091	SEPARADOR COJINETES SEPARATORE CUSCINETTI SPACER	DISTANZHULSE ENTRETOISE	1 2 3 4 5 6 7 8 9	
07A		00H01502201	CADENA SECUNDARIA 130 P CATENA SEZ. TRANSMISSION CHAIN	KETTE CHAINE TRANSMISSION	1 2 4 5 7 8	
07B		00H01506201	CADENA SECUNDARIA 136 P CATENA SEZ. TRANSMISSION CHAIN	KETTE CHAINE TRANSMISSION	3 6 9	
08A		00002182000	TORNILLO C/EXAG.8M125X20 VITE SCREW	SCHRAUBE VIS	1 2 3 4 5 6 7 8 9	
09A		00000023060	TUERCA AUTOBLOCANTE 6M100 DADO NUT	MUTTER ECROU	1 2 3 4 5 6 7 8 9	
10A		00D01301401	PROTECTOR CAMARA PROTEZIONE CAMERA RUOTA POSTER RIM STRIP	FELGELBAND PROTECTEUR DE CHAMBRE A AIR	1 2 3 4 5 6 7 8 9	



FWD

**RUEDA SIN DISCO Y SIN PLATO
WHEEL WITHOUT DISC AND DRIVE PLATE**

Fig.	Ver.	COD. KOD.	DESCRIPCIÓN DENOMINAZIONE NAME	BEZEICHNUNG DESIGNATION	MOD.	NOTAS NOTES NOTA MITSCHRIFT NOTES
11A		00H01302172	SCTO.TENSOR RUEDA SUBTENSORE RUOTA SEN ADJUSTER, REAR WHEEL	HINTERRADSPANNER TENDEUR DE ROUE ENSEMBLE	1 2 3 4 5 6 7 8 9	
12A		00F01210312	ARANDELA EJE RONDELLA WASHER	SCHEIBE RONDELLE	1 2 3 4 5 6 7 8 9	
13A		00262120032	TUERCA AUTOBLOCANTE 12M150 DADO NUT	MUTTER ECROU	1 2 3 4 5 6 7 8 9	
14A		00H01307821	CTO.CARRETE TRASERO MOZZO POST. REAR COIL	RADNABE MOYEU ARRIERE	1 2 3 4 5 6 7 8 9	
15A		00H01317032	PLATO ARRASTRE Z-53 PIATTO TRAINO DRIVE PLATE	MITNEHMERSCHEIBE COURONNE ARRIERE	1 2 4 5 7 8	
15B		00H01326031	PLATO ARRASTRE Z-65 PIATTO TRAINO DRIVE PLATE	MITNEHMERSCHEIBE COURONNE ARRIERE	3 6 9	
16A		00H01305531	DISCO FRENO TR. DISCO FRENO POSTERIORE REAR BRAKE DISC	BREMSSCHEIBE HINTEN DISQUE DE FREIN ARRIERE	1 2 3 4 5 6 7 8 9	
17A		00H01302351	R-LLANTA TRASERA 2,15X18 CERCHIONE POSTERIORE REAR RIM	HINTERRADFELGE JANTE ARRIERE NUE.	1 2 3 4 5 6 7 8 9	
18A		00H02401282	TORNILLO FIJ.DISCO FR.TR. VITE SCREW	SCHRAUBE VIS	1 2 3 4 5 6 7 8 9	
19A		00H01301501	RADIO TRASERO LADO PLATO RADIO POST.LATO PIATTO REAR INNER SPOKE	SPEICHE RAYON ROUE ARRIERE INT.	1 2 3 4 5 6 7 8 9	
20A		00H01301691	RADIO TRASERO LADO DISCO RADIO POST. DISCO REAR SHORT INNER SPOKE	SPEICHE RAYON ROUE AR INT.COURT	1 2 3 4 5 6 7 8 9	

**RUEDA SIN DISCO Y SIN PLATO
WHEEL WITHOUT DISC AND DRIVE PLATE**

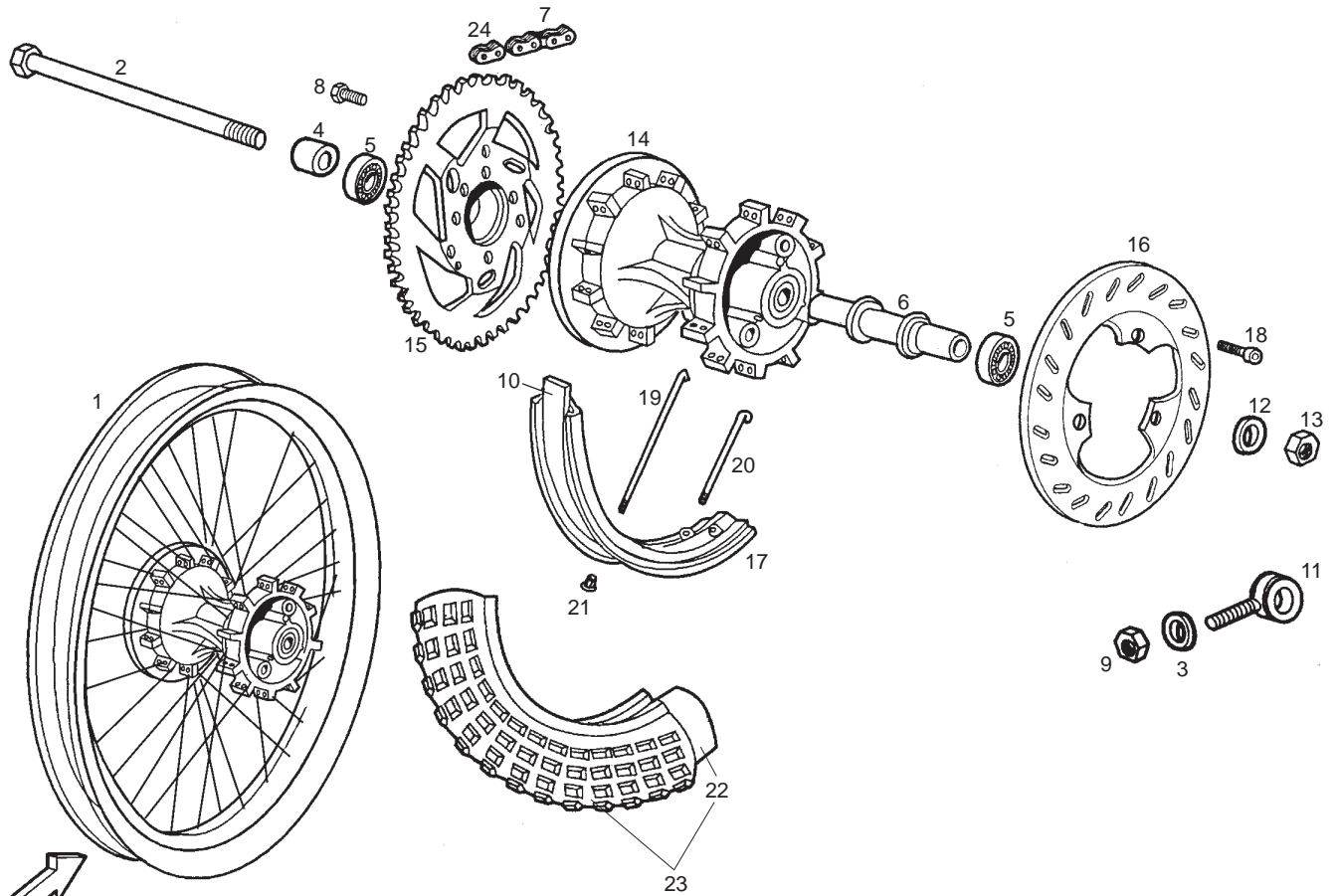

FWD

Fig.	Ver.	COD. KOD.	DESCRIPCIÓN DENOMINAZIONE NAME	BEZEICHNUNG DESIGNATION	MOD.	NOTAS NOTES NOTA MITSCHRIFT NOTES
21A		00002212070	TUERCA RADIO. DADO NUT	MUTTER ECROU	1 2 3 4 5 6 7 8 9	
22A		00H01308361	CAMARA CAMERA RUOTA POST. REAR WHEEL CAMBER	SCHLAUCH CHAMRE A AIR ARR.	1 2 3 4 5 6 7 8 9	
23A		00H01309321	CTO. CUBIERTA TRASERA 18" COPERTONE POST. REAR CASING	REIFEB HINTEN PNEU ARR.	1 2 3 4 5 6 7 8 9	
24A		00H01501212	R-ENGANCHE DORAD.CADENA SEC. AGGANCIAMENTO CATENA SICUREZZA MASTER LINK	KETTENSHLOSS ATTACHE RAPIDE	1 2 3 4 5 6 7 8 9	

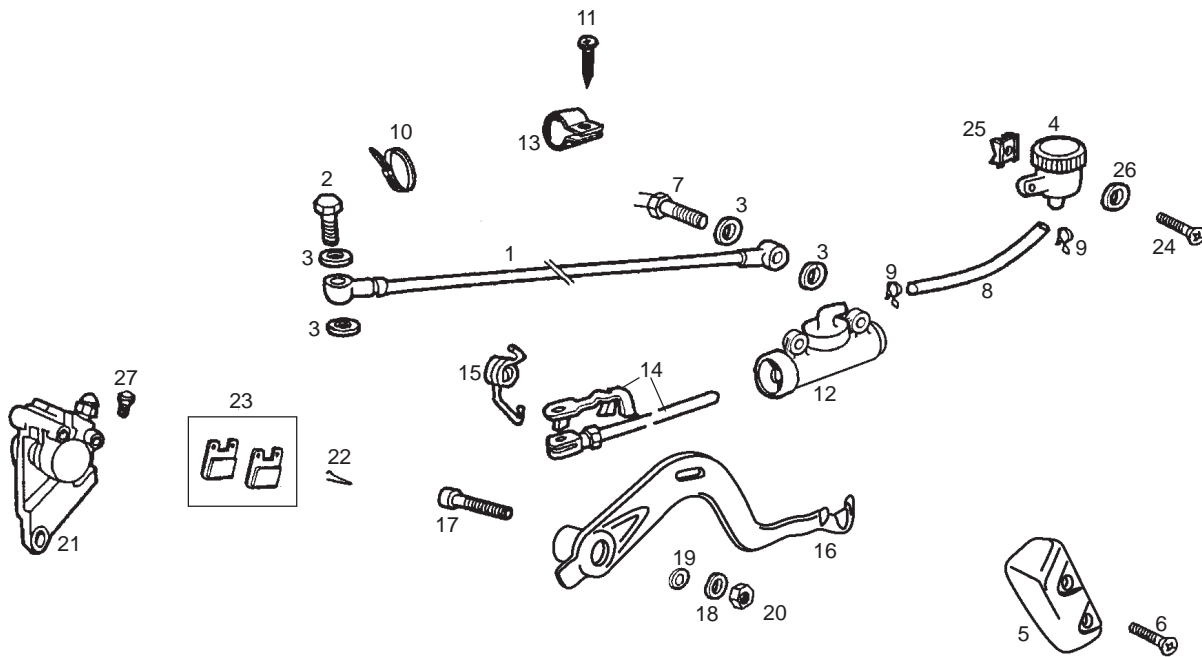

Fig.	Ver.	COD. KOD.	DESCRIPCIÓN DENOMINAZIONE NAME	BEZEICHNUNG DESIGNATION	MOD.	NOTAS NOTES NOTA MITSCHRIFT NOTES
01A		00H01109081	TUBO LIQUIDO FRENO TRASERO TUBO LIQUIDO FRENO BRAKE ROD	BREMSSCHLAUCH TIGE DE FREIN	1 2 3 4 5 6 7 8 9	
02A		00006309260	RACORD TUBO HIDRAULICO RACCORDO TUBO IDRAULICO HYDRAULIC TUBE CONNECTOR	STUTZEN HIDRAULIKLEITUNG RACCORD TUYAU HYDRAULIQUE	1 2 3 4 5 6 7 8 9	
03A		00006321040	ARANDELA JUNTA RACORD RONDELLA WASHER	SCHEIBE RONDELLE	1 2 3 4 5 6 7 8 9	
04A		00D01100201	CTO. DPSTO. LIQUIDO FRENO TRASERO SERBATOIO LIQUIDO FR FLUID TUBE TANK	BEHALTER RESERVOIR FLUID TUBE	1 2 3 4 5 6 7 8 9	
05A		00H01101731	PROTECT.BOMBA PROTEZIONE FRENO POSTERIORE REAR BRAKE, PROTECTOR	ABDECKUNG PROTECTEUR ENS.COMMANDE FRE	1 2 3 4 5 6 7 8 9	
06A		00G01503701	TORNILLO VITE SCREW	SCHRAUBE VIS	1 2 3 4 5 6 7 8 9	
07A		00H01001701	CTO. INTERRUPTOR STOP COMP.INTERUTTORE FANALINO SWITCH, STOP LIGHT	STOPCHALTER VO. INTERRUPTEUR COMMANDE STOP	1 2 3 4 5 6 7 8 9	
08A		00H01101211	TUBO DPSTO. A BOMBA FRENO TRAS. TUBO SERBATOIO A POMPA FRENO P REAR FLUID TUBE	SCHLAUCH FLEXIBLE DE FREIN ARRIERE	1 2 3 4 5 6 7 8 9	
09A		00H03700131	ABRAZADERA ELASTICA RONDELLA STELLA INTERIORE ELASTIC CLAMP	SHELLE ELAST. COLLIER ELASTIQUE	1 2 3 4 5 6 7 8 9	
10A		00F00900531	BRIDA FLANGIA UNIONE CAVI BLACK CABLE TIE	KABELBINDER COLLIER	1 2 3 4 5 6 7 8 9	
11A		00011041300	TORNILLO AUTORROS.4,8X13 VITE SCREW	SCHRAUBE VIS	1 2 3 4 5 6 7 8 9	

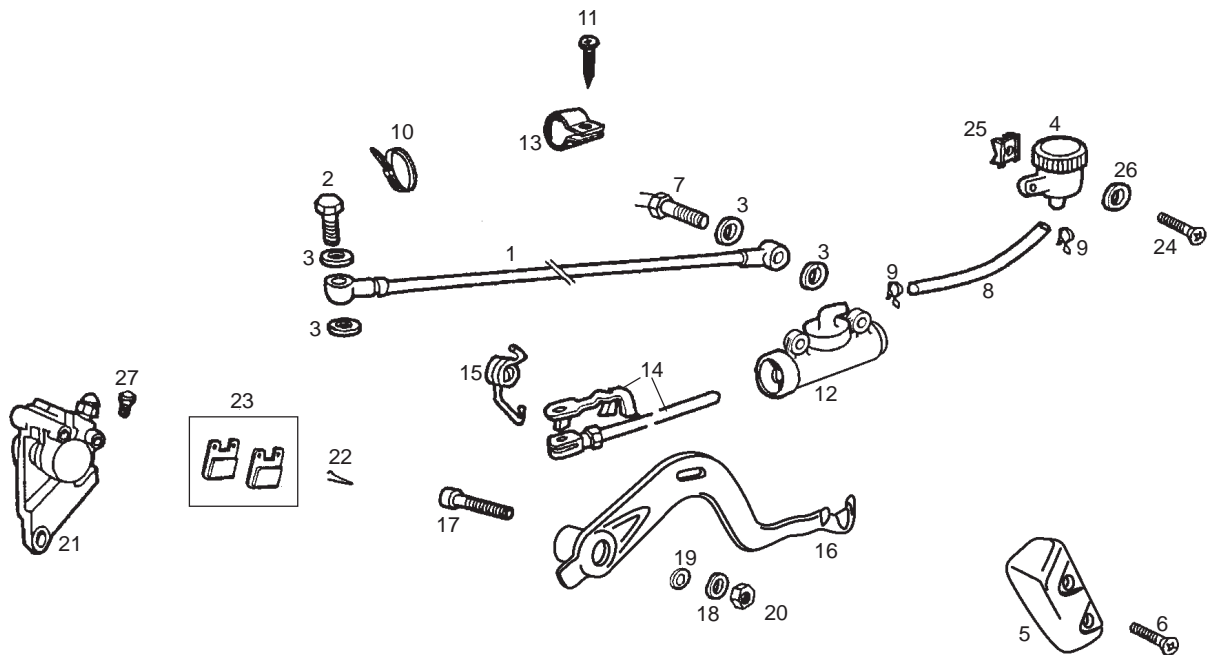

Fig.	Ver.	COD. KOD.	DESCRIPCIÓN DENOMINAZIONE NAME	BEZEICHUNG DESIGNATION	MOD.	NOTAS NOTES NOTA MITSCHRIFT NOTES
12A		00H01106181	CTO BOMBA FRENO TRASERO FRENO POSTERIORE REAR BRAKE CONTROL ASSY	REAR BRAKE CONTROL ASSY. ENSEMBLE COMMANDE FREIN ARRIER	1 2 3 4 5 6 7 8 9	
13A		00H01501811	BRIDA FLANGIA CLAMP	BEF.-SCHELLE ENTRETOISE	1 2 3 4 5 6 7 8 9	
14A		00H01103611	CTO.VARILLA BOMBA FRENO COMP.ASTA POMPA FRENO REAR BRAKE ROD	BREMSSTANGE TIGE DE FREIN ARRIERE	1 2 3 4 5 6 7 8 9	
15A		00H01102072	MUELLE PEDAL FR. TRASERO MOLLA PEDALE FRENO POSTERIORE SPRING PEDAL BRAKE	FEDER RESSORT PEDALE FREIN	1 2 3 4 5 6 7 8 9	
16A		00H01120021	PALANCA FRENO PEDALE FRENO BRAKE PEDAL	FUSSBREMSHEBEL PEDALE DE FREIN AR.	1 2 3 4 5 6 7 8 9	
17A		00H01100172	TORNILLO FIJACION PALANCA VITE PEDALE FRENO BRAKE PEDAL BRAKE	INBUSSCHRAUBE FUSSBREMSHEBEL BOULON PEDALE DE FREIN	1 2 3 4 5 6 7 8 9	
18A		00402080001	ARANDELA D8 RONDELLA WASHER	SCHEIBE RONDELLE	1 2 3 4 5 6 7 8 9	
19A		00005527540	ARANDELA RONDELLA WASHER	SCHEIBE RONDELLE	1 2 3 4 5 6 7 8 9	
20A		00023108000	TUERCA AUTOBLOCANTE 8M125 DADO NUT	MUTTER ECROU	1 2 3 4 5 6 7 8 9	
21A		00H01104583	R-CTO PINZA FRENO TRASERA PINZA REAR CLIP ASSEMBLY	BREMSZANGE HINTEN ETRIER FREIN ARR.	1 2 3 4 5 6 7 8 9	
22A		00H01301831	MUELLE FIJACION MOLLA FISSAGGIO PASTIGLIA FREN REAR BRAKE PAD SECUR SPR.	FEDER RESSORT FIXATION PLAQUETTE	1 2 3 4 5 6 7 8 9	

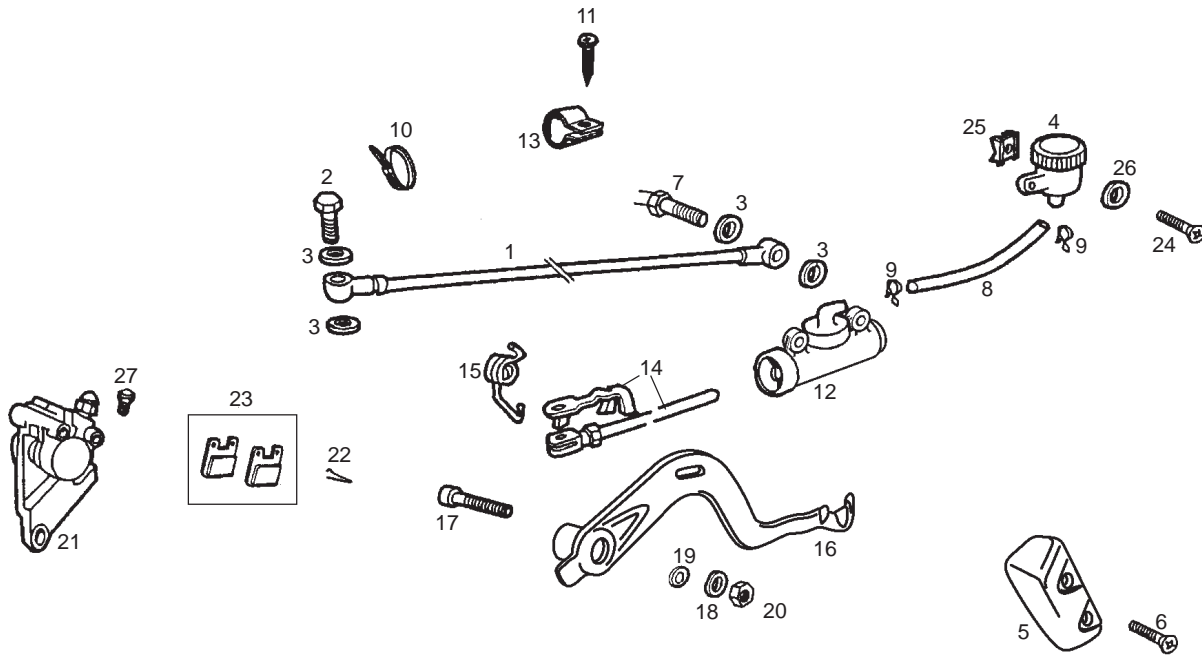

Fig.	Ver.	COD. KOD.	DESCRIPCIÓN DENOMINAZIONE NAME	BEZEICHNUNG DESIGNATION	MOD.	NOTAS NOTES NOTA MITSCHRIFT NOTES
23A		00G04700141	JUEGO PASTILLAS DE FRENO CONG. PASTIGLIE FRENO SET OF BRAKE PADS	DIE GESAMTHEIT BREMSBACKEN ENS. PLAQUETTE DE FREIN	1 2 3 4 5 6 7 8 9	
24A		00012151500	TORNILLO C/RED.ALLEN.5M100X16 VITE SCREW	SCHRAUBE VIS	1 2 3 4 5 6 7 8 9	
25A		00G04401462	TUERCA FIJACION D5 DADO NUT	MUTTER ECROU	1 2 3 4 5 6 7 8 9	
26A		00D02600631	ARANDELA RONDELLA WASHER	SCHEIBE RONDELLE	1 2 3 4 5 6 7 8 9	
27A		00F04700121	R-CTO. PURGADOR PINZA FRENO R-SPURGO FRONT BRAKE BLEED CLIP ASSY	ABLASSHAHN R-ENS.PURGEUR PINCE FREIN A	1 2 3 4 5 6 7 8 9	

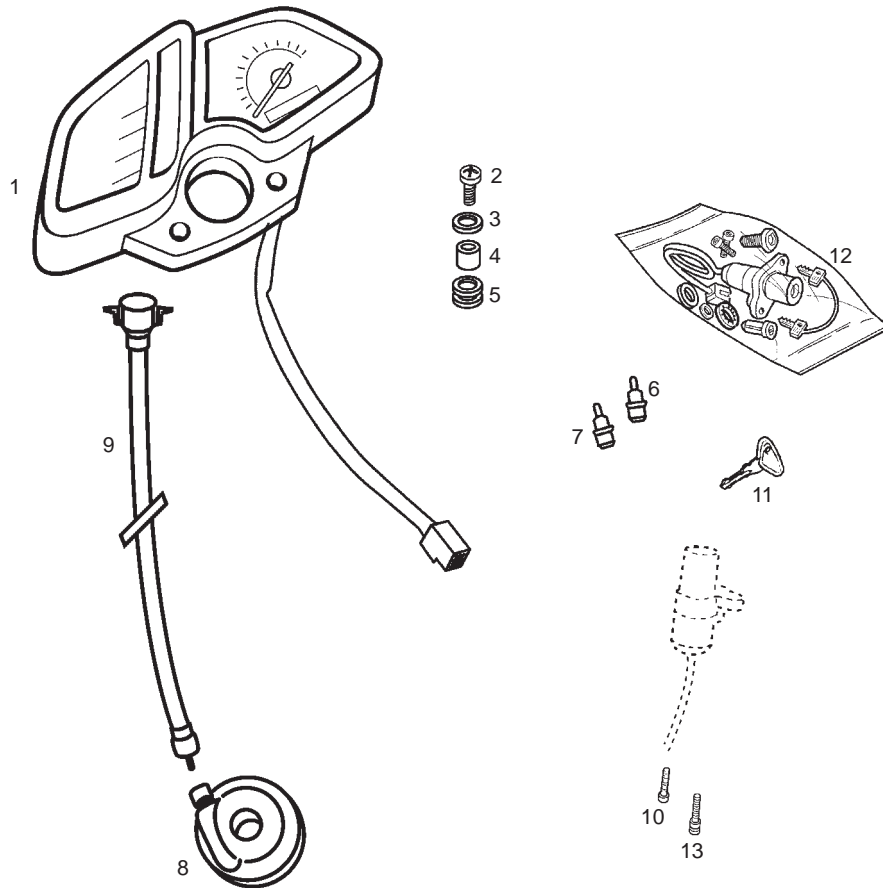

Fig.	Ver.	COD. KOD.	DESCRIPCIÓN DENOMINAZIONE NAME	BEZEICHUNG DESIGNATION	MOD.	NOTAS NOTES NOTA MITSCHRIFT NOTES
01A		00H01625521	CTO TABLIER (KM/H) CRUSCOTTO (KM/H) DASH ASSY (KM/H)	INSTRUMENTERHALTER (KM/H) BOITIER TABLEAU BORD (KM/H)		UNTIL FRAME 7H379833
01B		00H01628521	CTO TABLIER (MPH) CRUSCOTTO (MILE/H) DASH ASSY (MILE/H)	INSTRUMENTERHALTER (MILE/H) BOITIER TABLEAU BORD (MILE/H)		MILES PER HOUR
01C		864515	CTO TABLIER (KM/H) CRUSCOTTO (KM/H) DASH ASSY (KM/H)	INSTRUMENTERHALTER (KM/H) BOITIER TABLEAU BORD (KM/H)		SINCE FRAME 7H379834
02A		00012152000	TORNILLO C/RED.CRUZ 5M80X20 VITE SCREW	SCHRAUBE VIS	1 2 3 4 5 6 7 8 9	
03A		00D02600631	ARANDELA RONDELLA WASHER	SCHEIBE RONDELLE	1 2 3 4 5 6 7 8 9	
04A		00H01600911	CASQUILLO GHIERA SILENT.FISS.CRUSCOT.FE BUSHING	FUHRUNGSBUCHSE GABELSCHENK ENTRETOISE	1 2 3 4 5 6 7 8 9	
05A		00D01500021	PASACABLES PORTACAVI IST. FARAFANGO POST. GROMMET	GUMMI CAOUTCHOUC PASSE-CABLE	1 2 3 4 5 6 7 8 9	
06A		00G01602581	R-CTO. PORTALAMP/LAMP. 12V 1,2 W PORTALAMPADE BULB HOLDER AND BULB	LAMPENHALTER R-PORTE-LAMPES	1 2 3 4 5 6 7 8 9	
07A		00G01601581	R-CTO. PORTALAMP/LAMP. 12V 2 W PORTALAMPADE BULB HOLDER AND BULB	LAMPENHALTER R-PORTE-LAMPES	1 2 3 4 5 6 7 8 9	
08A		00G01606051	CTO. REENVIO. RINVIO RETURN UNIT.	RETURN UNIT. RENOI DE ROUE	1 2 3 4 5 6 7 8 9	
09A		00H01616021	CTO. CABLE-FUNDA CUENTA KM CAVO-GUAINA CONTACHI CABLE, SPEEDOMETER DRIVE	TACHOWELLE ENSEMB.CABLE-GAINE COMPTEUR	1 2 3 4 5 6 7 8 9	

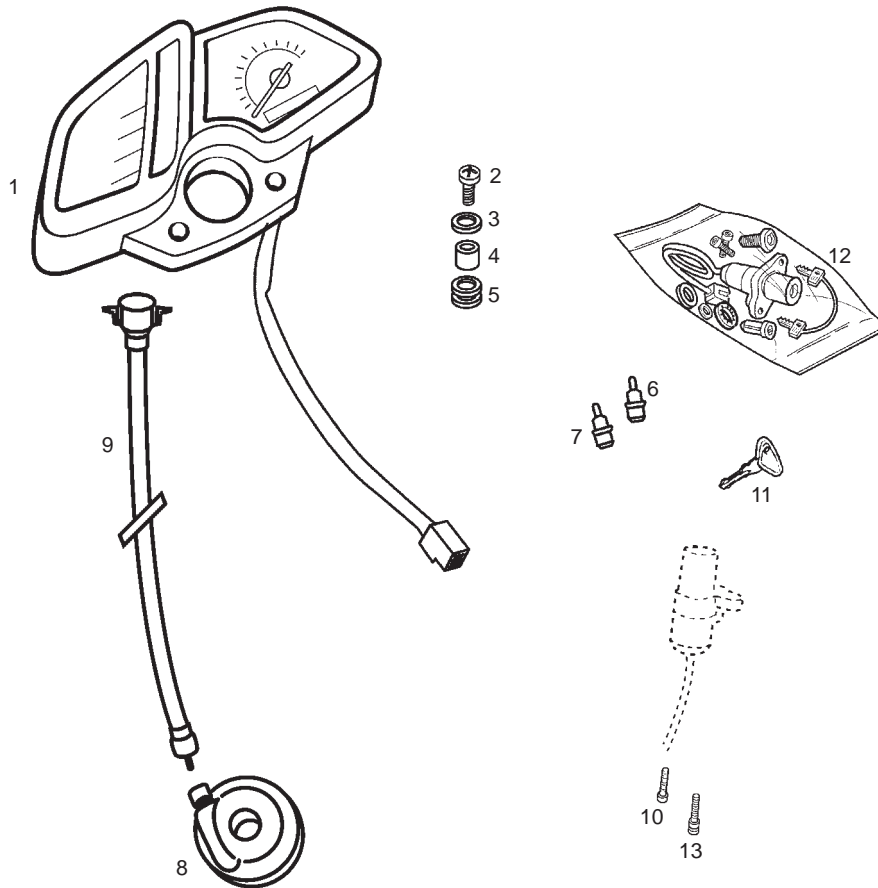

Fig.	Ver.	COD. KOD.	DESCRIPCIÓN DENOMINAZIONE NAME	BEZEICHNUNG DESIGNATION	MOD.	NOTAS NOTES NOTA MITSCHRIFT NOTES
10A		00002082021	TORNILLO 8M125X20 VITE SCREW	SCHRAUBE VIS	1 2 3 4 5 6 7 8 9	
11A		00H01801411	LLAVE CONTACTO POR MECANIZAR CHIAVE LOCK KEYS	SCHLUSSEL CLEF	1 2 3 4 5 6 7 8 9	
12A		00H05908251	R-CTO. KIT CERRDADURAS SIN LEVAS SERRATURE SENZA LEVA LOCK WITH KEYS WITHOUT LEVER	SCHLOOS-SATZ OHNE VERSCHLUSSH. ENS. KIT SERRURES SANS LEVIER	1 2 3 4 5 6 7 8 9	
13A		00H06300791	TORNILLO ROMPIENTE VITE SCREW	SCHRAUBE VIS	1 2 3 4 5 6 7 8 9	

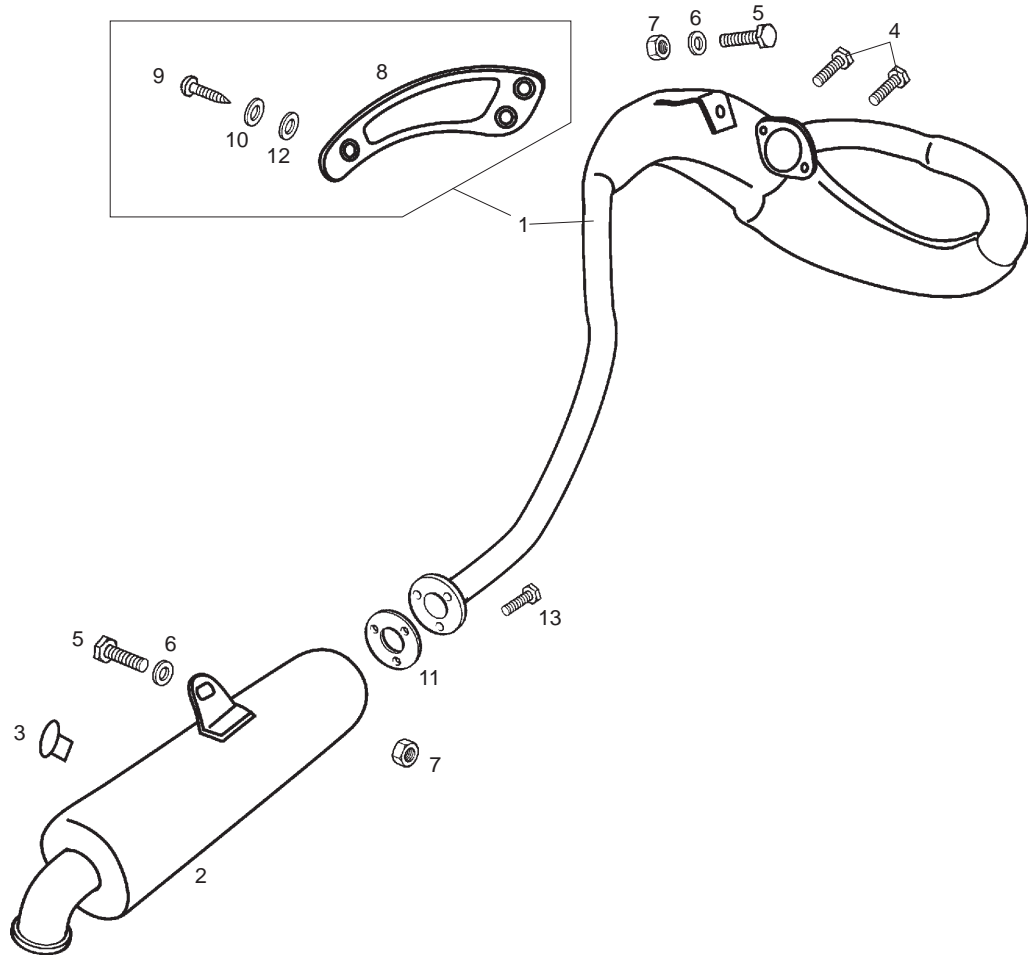

Fig.	Ver.	COD. KOD.	DESCRIPCIÓN DENOMINAZIONE NAME	BEZEICHNUNG DESIGNATION	MOD.	NOTAS NOTES NOTA MITSCHRIFT NOTES
01A		862964	TUBO ESCAPE SUBCOMP.TUBO SCAPP-SIL. EXHAUST PIPE AND MUFFLER	AUSPUFF ENSEMBLE TUBE DIECHAPPEMENT	1 2 4 5 7 8	
01B		00H03446081	SCTO TUBO ESCAPE SENDA R E2 SUBCOMP.TUBO SCAPP-SIL. EXHAUST PIPE AND MUFFLER	AUSPUFF ENSEMBLE TUBE DIECHAPPEMENT	3 6 9	
02A		00H03429412	SCTO SORDINA SUBCOMP.SORD. EXHAUST TANK	SCHALLDAMPFER SILENCIEUX DIECHAPPEMENT	1 2 3 4 5 6 7 8 9	
03A		00G01500951	TOPE GOMA APPOGGIO ZAMPA CAVALLETO SIDE STAND REST	GUMMISTOPPEL APPUI BEQUILLE LATERALE	1 2 3 4 5 6 7 8 9	
04A		00002062011	TORNILLO C/ALLEN.6M100X20 VITE SCREW	SCHRAUBE VIS	1 2 3 4 5 6 7 8 9	
05A		00012081621	TORNILLO 8M125X16 VITE SCREW	SCHRAUBE VIS	1 2 3 4 5 6 7 8 9	
06A		00402080001	ARANDELA D8 RONDELLA WASHER	SCHEIBE RONDELLE	1 2 3 4 5 6 7 8 9	
07A		00023108000	TUERCA AUTOBLOCANTE 8M125 DADO NUT	MUTTER ECROU	1 2 3 4 5 6 7 8 9	
08A		00H01800402	PROTECTOR SILENCIADOR PROTEZIONE SILENZIATORE SILENCER SHIELD	SCHALLDAEMPERSCHUTZ PROTECT.SIL.	1 2 3 4 5 6 7 8 9	
09A		00000012415	TORNILLO VITE SCREW	SCHRAUBE VIS	1 2 3 4 5 6 7 8 9	
10A		00F04201361	REMACHE RIBADITURA RIVET	RIVET RIVET	1 2 3 4 5 6 7 8 9	

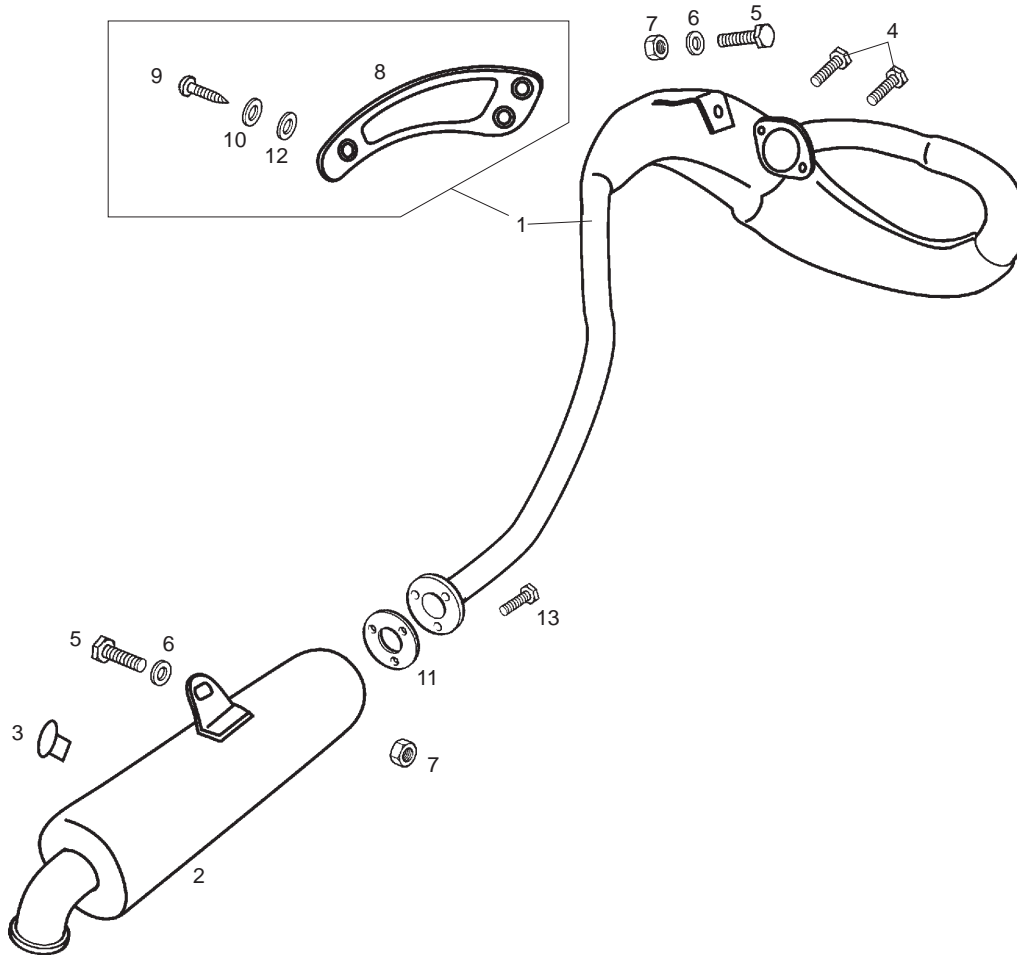
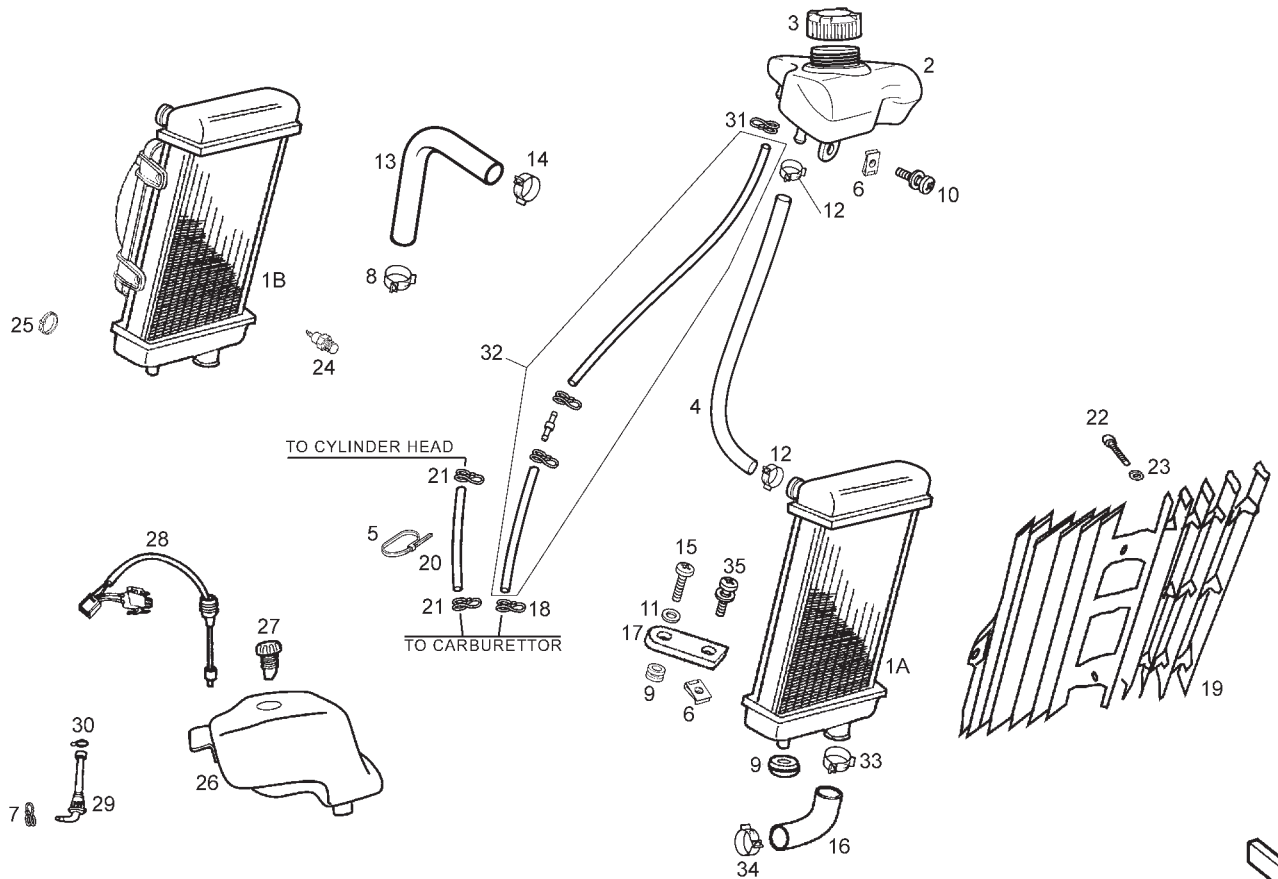

Fig.	Ver.	COD. KOD.	DESCRIPCIÓN DENOMINAZIONE NAME	BEZEICHNUNG DESIGNATION	MOD.	NOTAS NOTES NOTA MITSCHRIFT NOTES
11A		00H03404321	JUNTA GUARNIZIONE GASKET	DICHTUNG JOINT	1 2 3 4 5 6 7 8 9	
12A		00D02600631	ARANDELA RONDELLA FERMO MOLLA FRIZIONE CLUTCH SPRING STOP WASHER	SCHEIBE ROND.BUTEE RESSORT EMBRAYA.	1 2 3 4 5 6 7 8 9	
13A		00D05910081	TORNILLO VITE SCREW	SCHRAUBE VIS	1 2 3 4 5 6 7 8 9	

1st VERSION



FWD

Fig.	Ver.	COD. KOD.	DESCRIPCIÓN DENOMINAZIONE NAME	BEZEICHNUNG DESIGNATION	MOD.	NOTAS NOTES NOTA MITSCHRIFT NOTES
01A		00H03805011	SCTO. RADIADOR SUBRADIATORE RADIATOR ASSY.	RADIATOR ASSY. RADIATEUR	1 4 7	
01B		00H03802541	CTO. RADIADOR CON ELECTROVENT. SUBRADIATORE RADIATOR ASSY.	RADIATOR ASSY. RADIATEUR	2 3 5 6 8 9	
02A		00H03810501	DEPOSITO AGUA RADIADOR SERBATOIO ACQUA RADIATORE WATER TANK	WASSERBEHALTER VASE DI EXPANSION	1 2 4 5 7 8	
02B		00H03802501	DEPOSITO AGUA RADIADOR SERBATOIO ACQUA RADIATORE WATER TANK	WASSERBEHALTER VASE DI EXPANSION	3 6 9	ONLY SCANDINAVIA
03A		00H03802472	CTO.TAPON DEPOSITO AGUA TAPPO RADIATORE/SERBATOIO WATER RESERVOIR/RAD CAP ASSY	KUEHLERDECKEL BOUCHON DE RESERVOIR D,EAU	1 2 3 4 5 6 7 8 9	
04A		00G03800601	TUBO DEPOSITO-RADIADOR TUBO TUBE	SCHLAUCH TUYAU	1 2 3 4 5 6 7 8 9	UNTIL FRAME 7H359740
05A		00D00900531	BRIDA 200 X 3,6 FLANGIA UNIONE CAVI BLACK CABLE TIE	KABELBINDER COLLIER	1 2 4 5 7 8	
06A		00D01501371	TUERCA FIJ. D6 DADO NUT	MUTTER ECROU	1 2 3 4 5 6 7 8 9	
07A		00F03710131	ABRAZADERA ELASTICA FASCETTA CLAMP	FLANGE BRIDE	1 2 3 4 5 6 7 8 9	
08A		00H03802751	ABRAZADERA 24/8W4 FASCETTA CLAMP	BEF. SCHELLE COLLIER	1 2 3 4 5 6 7 8 9	
09A		00008915020	PROTECCION CABLES PROTEZIONE CAVI RUBBER,CABLE PROTECTOR	GUMMI PASSE-CABLE	1 2 3 4 5 6 7 8 9	

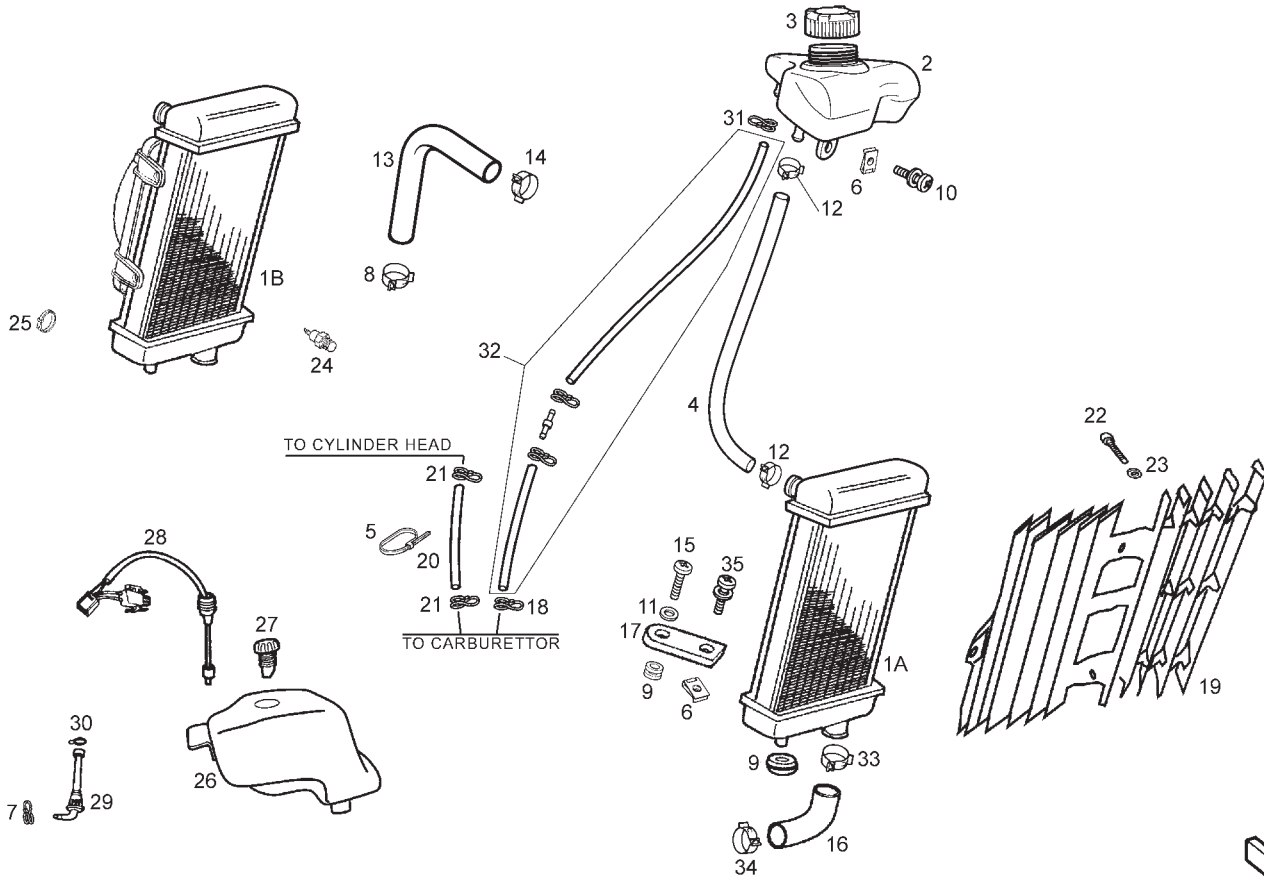

1st VERSION



Fig.	Ver.	COD. KOD.	DESCRIPCIÓN DENOMINAZIONE NAME	BEZEICHNUNG DESIGNATION	MOD.	NOTAS NOTES NOTA MITSCHRIFT NOTES
10A		00H05900021	SCTO TORNILLO 6M100X16 VITE SCREW	SCHRAUBE VIS	1 2 3 4 5 6 7 8 9	
11A		00D01500552	CAZOLETA SCADELLINO FISSAGGIO HOUSING EXHAUST PIPE SUPPORT	ABDECKSCHEIBE CUVETTE	1 2 3 4 5 6 7 8 9	
12A		00G03801701	ABRAZADERA FASCETTA FISSAGGIO MANICA RADI CLAMP FASTERING RADIATOR BUSHI	OIL TANK FLANGE TUBE BRIDE TUBE RESPIRATION RÏSERVO	1 2 3 4 5 6 7 8 9	UNTIL FRAME 7H359740
13A		00H03808021	TUBO CULATA-RADIADOR TUBO TESTATA-RACCORDO TERMOCON CYLINDER HEAD PIPE-TERMOCONTAC	WASSERSCHLAUCH TUBE	1 2 3 4 5 6 7 8 9	
14A		00H03800751	ABRAZADERA 21/8W4 FLANGIA FISSAGGIO SECURING CLAMP	BEF.-SHELLE COLLIER	1 2 3 4 5 6 7 8 9	
15A		00092061214	TORNILLO C/RED CRUZ 6M100X12 VITE SCREW	SCHRAUBE VIS	1 2 3 4 5 6 7 8 9	
16A		00H03802031	TUBO BOMBA-RADIADOR TUBO REFRIGERAZIONE POMPA-RADI RADIATOR PUMP RUBBER TUBE	KUHLMITTELSCHLAUCH PUMPE K TUBE POMPE-RADIATEUR	1 2 3 4 5 6 7 8 9	UNTIL FRAME 7H359740
17A		00G02200692	OREJA SUP.SOPORTE RADIADOR PIASTRA SUPPORTO SUPERIORE UPPER RADIATOR SUPPORT	OESE KUEHLERBLOCK OERILLE SUPERIEURE SUPPORT RAD	1 2 3 4 5 6 7 8 9	
18A		00H00400501	ABRAZADERA ELASTICA 7,8-8,3 FASCETTA CLAMP	FLANGE BRIDE	1 2 4 5 7 8	UNTIL FRAME 7H359740
19A		00H03805301	REJILLA RADIADOR GRIGLIA RADIATORE RADIATOR GRID	RADIATOR RADIATEUR	1 2 3 4 5 6 7 8 9	
20A		00H03801961	TUBO CARBURADOR A RACORD CULATA TUBO TUBE	SCHLAUCH TUYAU	1 2 4 5 7 8	

1st VERSION

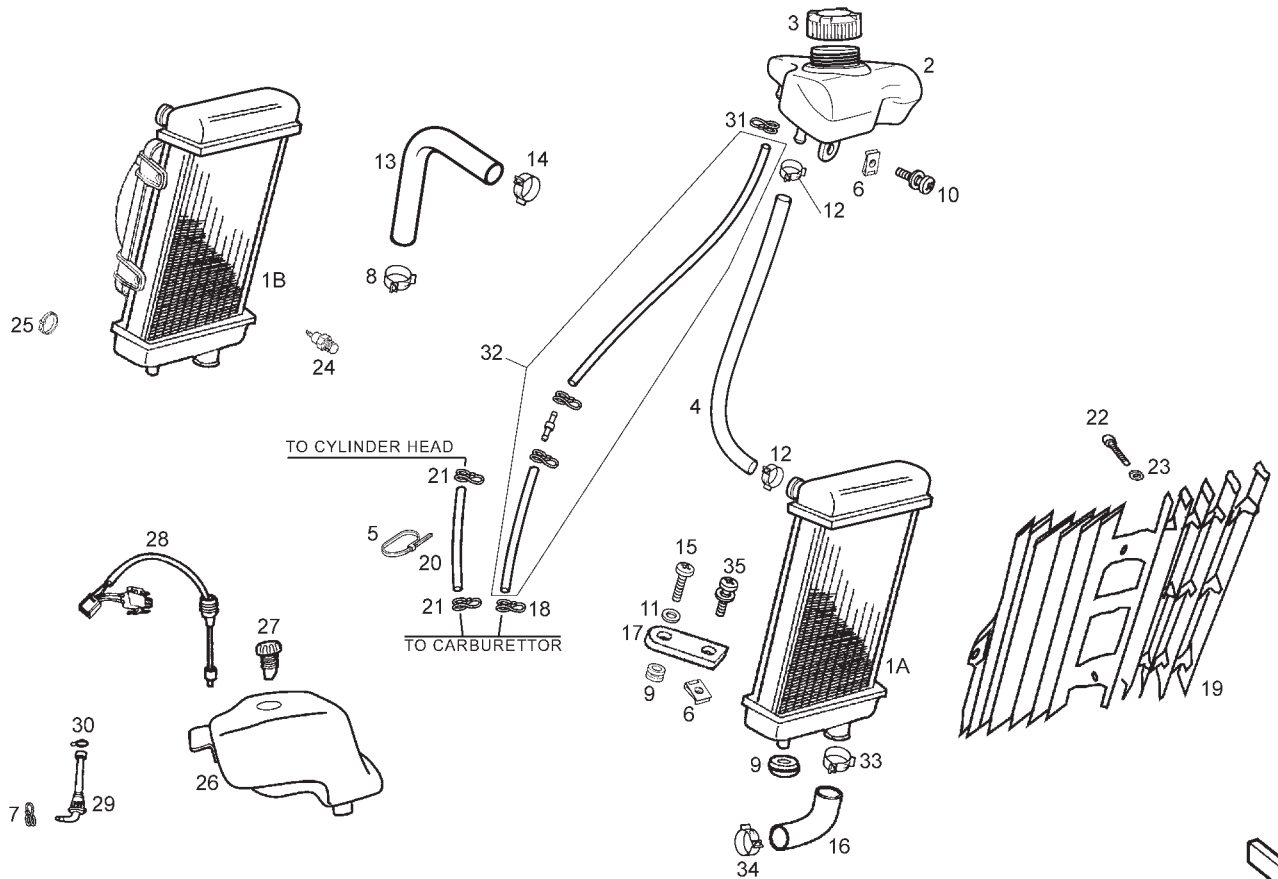

FWD

Fig.	Ver.	COD. KOD.	DESCRIPCIÓN DENOMINAZIONE NAME	BEZEICHNUNG DESIGNATION	MOD.	NOTAS NOTES NOTA MITSCHRIFT NOTES
21A		00H00400501	ABRAZADERA ELASTICA 7,8-8,3 FASCETTA CLAMP	FLANGE BRIDE	1 2 4 5 7 8	
22A		00011141300	TORNILLO AUT.C/CR.NG.4,8X13 VITE SCREW	SCHRAUBE VIS	1 2 3 4 5 6 7 8 9	
23A		00D02600631	ARANDELA RONDELLA WASHER	SCHEIBE RONDELLE	1 2 3 4 5 6 7 8 9	
24A		00G03800741	TERMOCONTACTO ELECTROVENTILADOR TERMOCONTATTO ELETTRVENTOLA THERMOCONTACT ELECTROVENTILATO	THEMPERATURFUHLER THERMOCONTACTEUR	2 3 5 6 8 9	
25A		00A00900531	BRIDA FLANGIA UNIONE CAVI BLACK CABLE TIE	KABELBINDER COLLIER	2 3 5 6 8 9	
26A		00H03704081	SCTO.DEPOSITO ACEITE SUBSERBATOIO OLIO SE OIL, TANK	OILTANK RESERVOIR D,HUILE	1 2 3 4 5 6 7 8 9	
27A		00F03710241	CTO.TAPON DEPOSITO ACEITE TAPPO SERBATOIO OLIO OIL RESERVOIR FILLER PLUG ASSY	STOPFEN OELTANK ENS. BOUCHON RESERV.HUILE S	1 2 3 4 5 6 7 8 9	
28A		00H03703051	CTO NIVEL ACEITE TAPPO SERBATOIO OLIO OIL RESERVOIR FILLER PLUG ASSY	OLSTANDSGEBER NIVEAU D#HUILE	1 2 3 4 5 6 7 8 9	SINCE FRAME 7H379833
28B		864490	CTO NIVEL ACEITE TAPPO SERBATOIO OLIO OIL RESERVOIR FILLER PLUG ASSY	OLSTANDSGEBER NIVEAU D#HUILE	1 2 3 4 5 6 7 8 9	UNTIL FRAME 7H379834
29A		00H03701411	CTO FILTRO ACEITE. FILTRO OLIO BY-PAS OIL FILTER	FILTER FILTRE A HUILE	1 2 3 4 5 6 7 8 9	
30A		00G00400501	ABRAZADERA FIJ. GRIFO FASCETTA ELASTICA CLAMP	BEF.-SCHELLE ENTRETOISE	1 2 3 4 5 6 7 8 9	

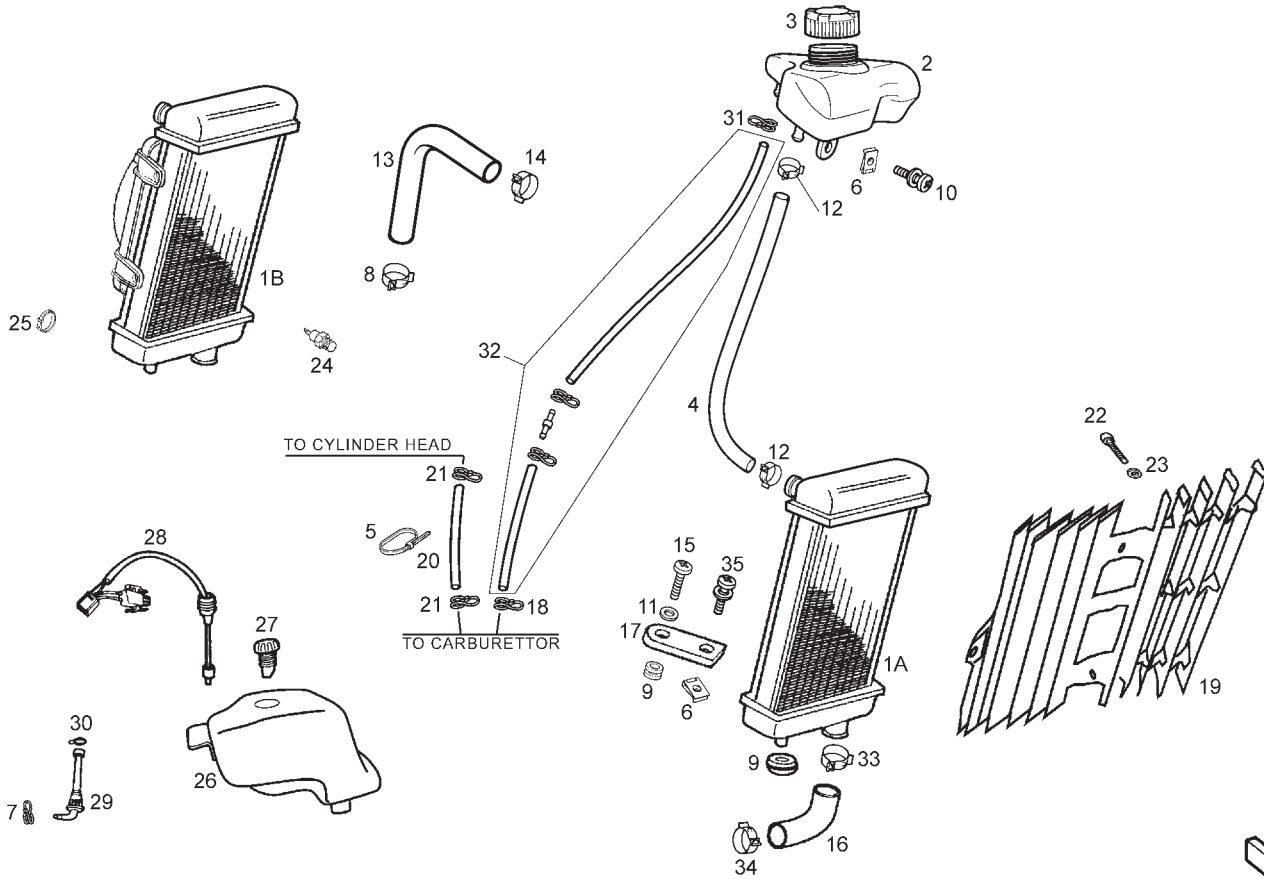

1st VERSION



Fig.	Ver.	COD. KOD.	DESCRIPCIÓN DENOMINAZIONE NAME	BEZEICHNUNG DESIGNATION	MOD.	NOTAS NOTES NOTA MITSCHRIFT NOTES
31A		00D03700131	ABRAZADERA ELASTICA 9,8-10,4 FASCETTA CLAMP	FLANGE BRIDE	1 2 4 5 7 8	UNTIL FRAME 7H359740
32A		00H03804971	SCTO TUBO DEPOSITO EXP-CARB. TUBO TUBE	SCHLAUCH TUYAU	1 2 4 5 7 8	UNTIL FRAME 7H359740
33A		00H03800751	ABRAZADERA 21/8 W4 FASCETTA CLAMP	FLANGE BRIDE	1 2 3 4 5 6 7 8 9	UNTIL FRAME 7H359740
34A		00H03802091	ABRAZADERA 23/8 W4 FASCETTA CLAMP	FLANGE BRIDE	1 2 3 4 5 6 7 8 9	UNTIL FRAME 7H359740
35A		00D05900031	SCTO TORNILLO 6M100X10 VITE SCREW	SCHRAUBE VIS	1 2 3 4 5 6 7 8 9	

2nd VERSION

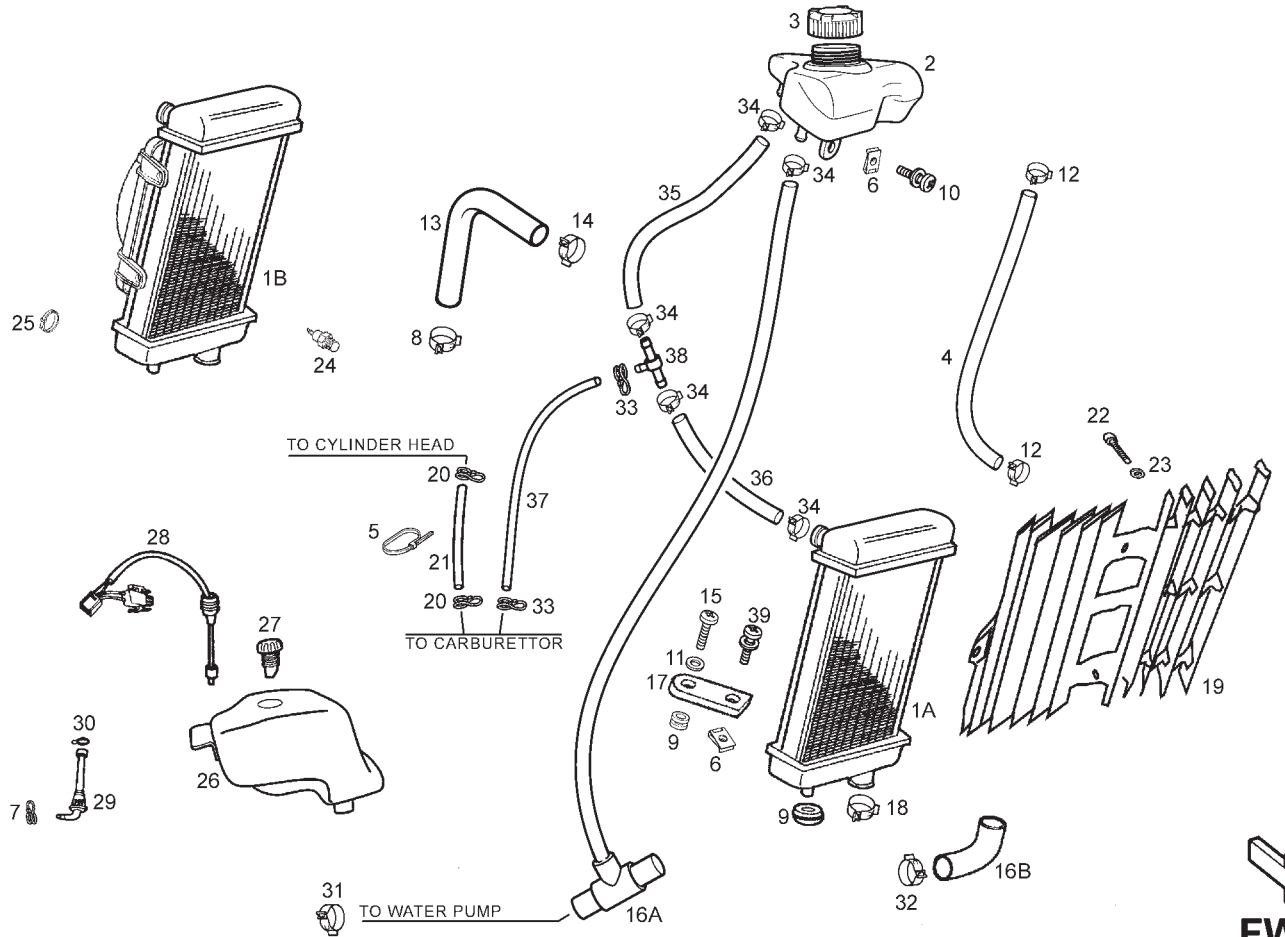
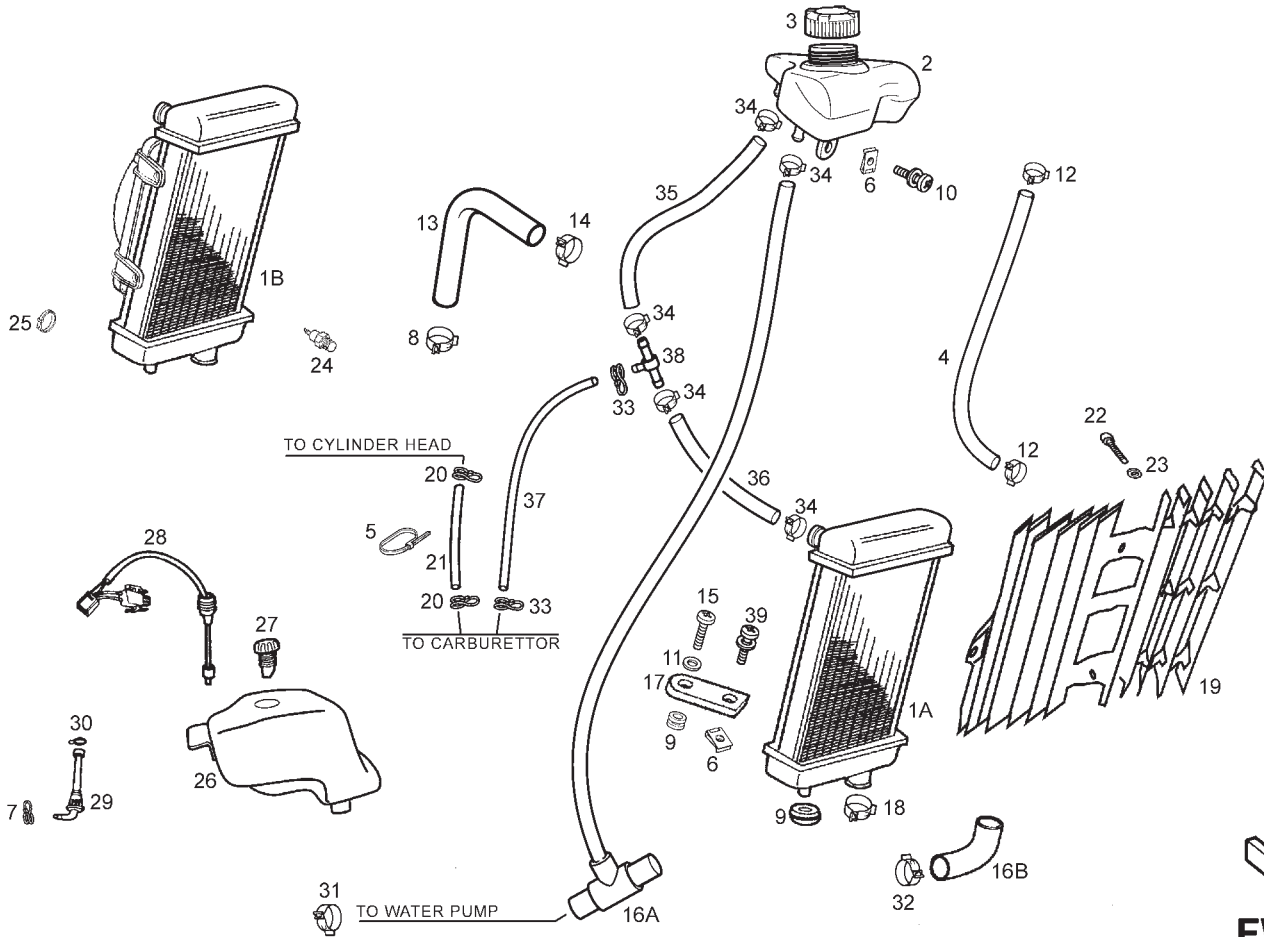

Fig.	Ver.	COD. KOD.	DESCRIPCIÓN DENOMINAZIONE NAME	BEZEICHNUNG DESIGNATION	MOD.	NOTAS NOTES NOTA MITSCHRIFT NOTES
01A		00H03805011	SCTO. RADIADOR SUBRADIATORE RADIATOR ASSY.	RADIATOR ASSY. RADIATEUR	1 4 7	
01B		00H03802541	CTO. RADIADOR CON ELECTROVENT. SUBRADIATORE RADIATOR ASSY.	RADIATOR ASSY. RADIATEUR	2 3 5 6 8 9	
02A		00H03810501	DEPOSITO AGUA RADIADOR SERBATOIO ACQUA RADIATORE WATER TANK	WASSERBEHALTER VASE DI EXPANSION	1 2 4 5 7 8	
02B		00H03802501	DEPOSITO AGUA RADIADOR SERBATOIO ACQUA RADIATORE WATER TANK	WASSERBEHALTER VASE DI EXPANSION	3 6 9	ONLY SCANDINAVIA
03A		00H03802472	CTO. TAPON DEPOSITO AGUA TAPPO RADIATORE/SERBATOIO WATER RESERVOIR/RAD CAP ASSY	KUEHLERDECKEL BOUCHON DE RESERVOIR D,EAU	1 2 3 4 5 6 7 8 9	
04A		00G03800601	TUBO DEPOSITO-RADIADOR TUBO TUBE	SCHLAUCH TUYAU	3 6 9	ONLY SCANDINAVIA
05A		00D00900531	BRIDA 200 X 3,6 FLANGIA UNIONE CAVI BLACK CABLE TIE	KABELBINDER COLLIER	1 2 4 5 7 8	
06A		00D01501371	TUERCA FIJ. D6 DADO NUT	MUTTER ECROU	1 2 3 4 5 6 7 8 9	
07A		00F03710131	ABRAZADERA ELASTICA FASCETTA CLAMP	FLANGE BRIDE	1 2 3 4 5 6 7 8 9	
08A		00H03802751	ABRAZADERA 24/8W4 FASCETTA CLAMP	BEF. SCHELLE COLLIER	1 2 3 4 5 6 7 8 9	
09A		00008915020	PROTECCION CABLES PROTEZIONE CAVI RUBBER,CABLE PROTECTOR	GUMMI PASSE-CABLE	1 2 3 4 5 6 7 8 9	



2nd VERSION

FWD

Fig.	Ver.	COD. KOD.	DESCRIPCIÓN DENOMINAZIONE NAME	BEZEICHNUNG DESIGNATION	MOD.	NOTAS NOTES NOTA MITSCHRIFT NOTES
10A		00H05900021	SCTO TORNILLO 6M100X16 VITE SCREW	SCHRAUBE VIS	1 2 3 4 5 6 7 8 9	
11A		00D01500552	CAZOLETA SCADELLINO FISSAGGIO HOUSING EXHAUST PIPE SUPPORT	ABDECKSCHEIBE CUVETTE	1 2 3 4 5 6 7 8 9	
12A		00G03801701	ABRAZADERA FASCETTA FISSAGGIO MANICA RADI CLAMP FASTERING RADIATOR BUSHI	OIL TANK FLANGE TUBE BRIDE TUBE RESPIRATION RÏSERVO	3 6 9	ONLY SCANDINAVIA
13A		00H03808021	TUBO CULATA-RADIADOR TUBO TESTATA-RACCORDO TERMOCON CYLINDER HEAD PIPE-TERMOCONTACT	WASSERSCHLAUCH TUBE	1 2 3 4 5 6 7 8 9	
14A		00H03800751	ABRAZADERA 21/8W4 FLANGIA FISSAGGIO SECURING CLAMP	BEF.-SHELLE COLLIER	1 2 3 4 5 6 7 8 9	
15A		00092061214	TORNILLO C/RED CRUZ 6M100X12 VITE SCREW	SCHRAUBE VIS	1 2 3 4 5 6 7 8 9	
16A		862493	TUBO RADIADOR A BOMBA/DEPOSITO TUBO REFRIGERAZIONE POMPA-RADI RADIATOR PUMP RUBBER TUBE	KUHLMITTELSCHLAUCH PUMPE K TUBE POMPE-RADIATEUR	1 2 4 5 7 8	SINCE FRAME 7H359741
16B		00H03802031	TUBO BOMBA-RADIADOR TUBO REFRIGERAZIONE POMPA-RADI RADIATOR PUMP RUBBER TUBE	KUHLMITTELSCHLAUCH PUMPE K TUBE POMPE-RADIATEUR	3 6 9	ONLY SCANDINAVIA
17A		00G02200692	OREJA SUP.SOPORTE RADIADOR PIASTRA SUPPORTO SUPERIORE UPPER RADIATOR SUPPORT	OESE KUEHLERBLOCK OREILLE SUPERIEURE SUPPORT RAD	1 2 3 4 5 6 7 8 9	
18A		00H03800751	ABRAZADERA 21/8 W4 FASCETTA CLAMP	FLANGE BRIDE	1 2 3 4 5 6 7 8 9	
19A		00H03805301	REJILLA RADIADOR GRIGLIA RADIATORE RADIATOR GRID	RADIATOR RADIATEUR	1 2 3 4 5 6 7 8 9	

2nd VERSION

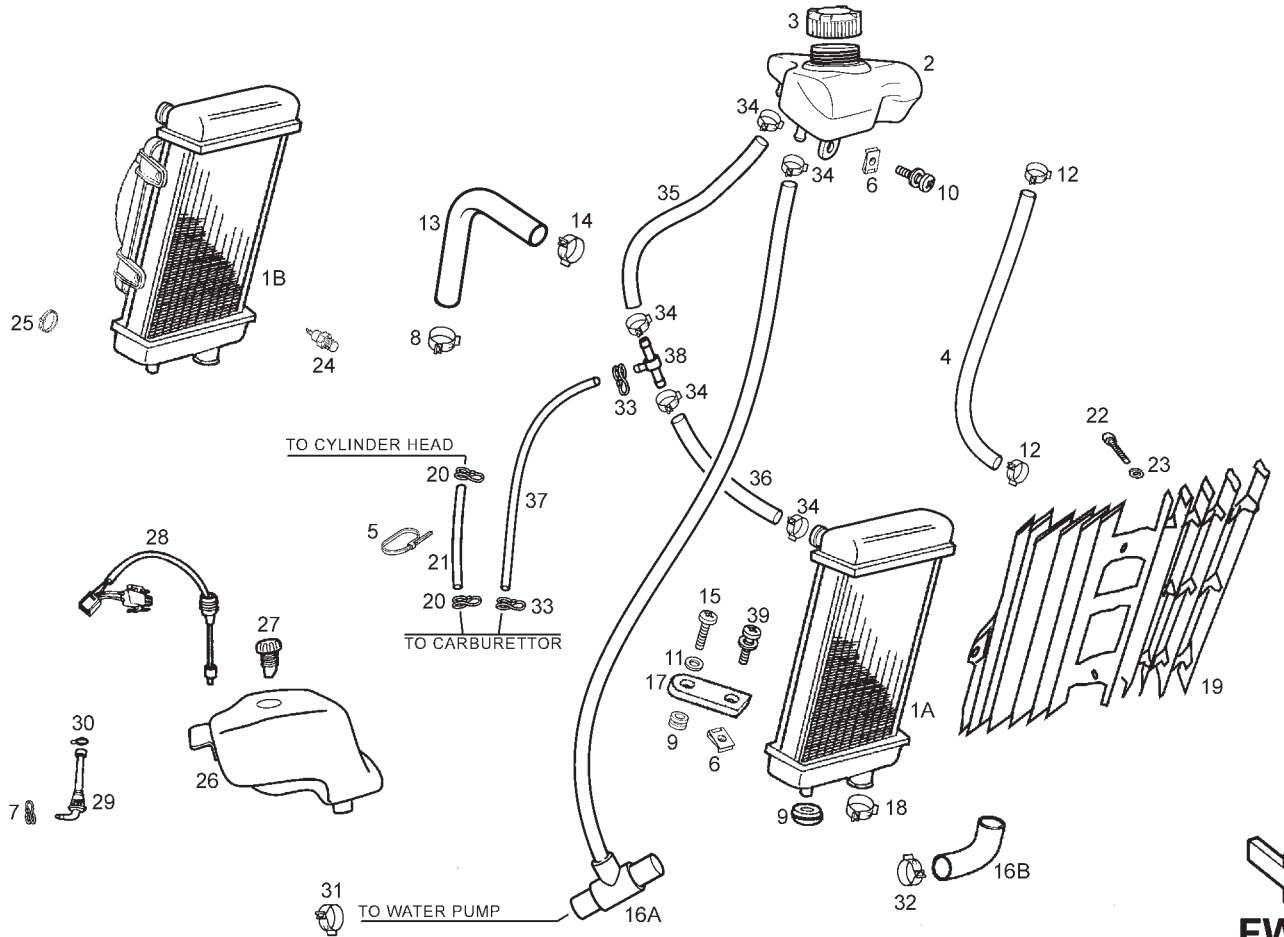
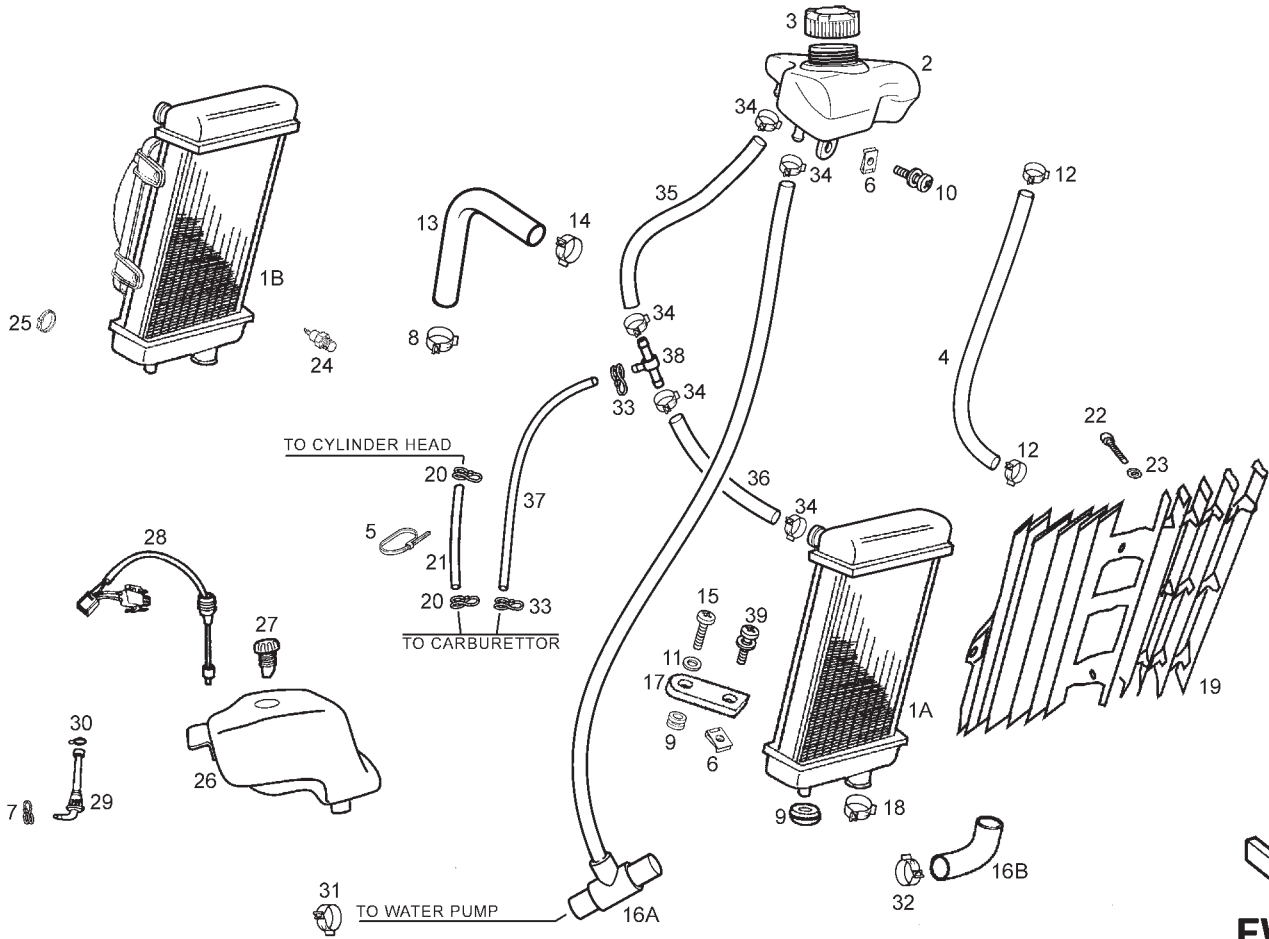

Fig.	Ver.	COD. KOD.	DESCRIPCIÓN DENOMINAZIONE NAME	BEZEICHNUNG DESIGNATION	MOD.	NOTAS NOTES NOTA MITSCHRIFT NOTES
20A		00H00400501	ABRAZADERA ELASTICA 7,8-8,3 TUBO TUBE	SCHLAUCH TUYAU	1 2 4 5 7 8	
21A		00H03801961	TUBO CARBURADOR A RACORD CULATA FASCETTA CLAMP	FLANGE BRIDE	1 2 4 5 7 8	
22A		00011141300	TORNILLO AUT.C/CR.NG.4,8X13 VITE SCREW	SCHRAUBE VIS	1 2 3 4 5 6 7 8 9	
23A		00D02600631	ARANDELA RONDELLA WASHER	SCHEIBE RONDELLE	1 2 3 4 5 6 7 8 9	
24A		00G03800741	TERMOCONTACTO ELECTROVENTILADOR TERMOCONTATTO ELETTROVENTOLA THERMOCONTACT ELECTROVENTILATO	TEMPERATURFUHLER THERMOCONTACTEUR	2 3 5 6 8 9	
25A		00A00900531	BRIDA FLANGIA UNIONE CAVI BLACK CABLE TIE	KABELBINDER COLLIER	2 3 5 6 8 9	
26A		00H03704081	SCTO.DEPOSITO ACEITE SUBSERBATOIO OLIO SE OIL, TANK	OILTANK RESERVOIR D,HUILE	1 2 3 4 5 6 7 8 9	
27A		00F03710241	CTO.TAPON DEPOSITO ACEITE TAPPO SERBATOIO OLIO OIL RESERVOIR FILLER PLUG ASSY	STOPFEN OELTANK ENS. BOUCHON RESERV.HUILE S	1 2 3 4 5 6 7 8 9	
28A		00H03703051	CTO NIVEL ACEITE TAPPO SERBATOIO OLIO OIL RESERVOIR FILLER PLUG ASSY	OLSTANDSGEBER NIVEAU D#HUILE	1 2 3 4 5 6 7 8 9	SINCE FRAME 7H379833
28B		864490	CTO NIVEL ACEITE TAPPO SERBATOIO OLIO OIL RESERVOIR FILLER PLUG ASSY	OLSTANDSGEBER NIVEAU D#HUILE	1 2 3 4 5 6 7 8 9	UNTIL FRAME 7H379834
29A		00H03701411	CTO.FILTRO ACEITE. FILTRO OLIO BY-PAS OIL FILTER	FILTER FILTRE A HUILLE	1 2 3 4 5 6 7 8 9	



2nd VERSION

FWD

Fig.	Ver.	COD. KOD.	DESCRIPCIÓN DENOMINAZIONE NAME	BEZEICHNUNG DESIGNATION	MOD.	NOTAS NOTES NOTA MITSCHRIFT NOTES
30A		00G00400501	ABRAZADERA FIJ. GRIFO FASCETTA ELASTICA CLAMP	BEF.-SCHELLE ENTRETOISE	1 2 3 4 5 6 7 8 9	
31A		00H03800751	ABRAZADERA 21/8 W4 FASCETTA CLAMP	FLANGE BRIDE	1 2 4 5 7 8	SINCE FRAME 7H359741
32A		00H03802091	ABRAZADERA 23/8 W4 FASCETTA CLAMP	FLANGE BRIDE	3 6 9	ONLY SCANDINAVIA
33A		00H00400501	ABRAZADERA ELASTICA FASCETTA CLAMP	FLANGE BRIDE	1 2 4 5 7 8	SINCE FRAME 7H359741
34A		00G03801701	ABRAZADERA 13/8 W4 FASCETTA CLAMP	FLANGE BRIDE	1 2 4 5 7 8	SINCE FRAME 7H359741
35A		862542	TUBO DEPOSITO A RACORD TUBO TUBE	SCHLAUCH TUYAU	1 2 4 5 7 8	SINCE FRAME 7H359741
36A		862544	TUBO RACORD A RADIADOR TUBO TUBE	SCHLAUCH TUYAU	1 2 4 5 7 8	SINCE FRAME 7H359741
37A		862543	TUBO RACORD A CARBURADOR TUBO TUBE	SCHLAUCH TUYAU	1 2 4 5 7 8	SINCE FRAME 7H359741
38A		862541	RACORD «T» RACCORDO RACORD	RACORD RACCORD	1 2 4 5 7 8	SINCE FRAME 7H359741
39A		00D05900031	SCTO TORNILLO 6M100X10 VITE SCREW	SCHRAUBE VIS	1 2 3 4 5 6 7 8 9	

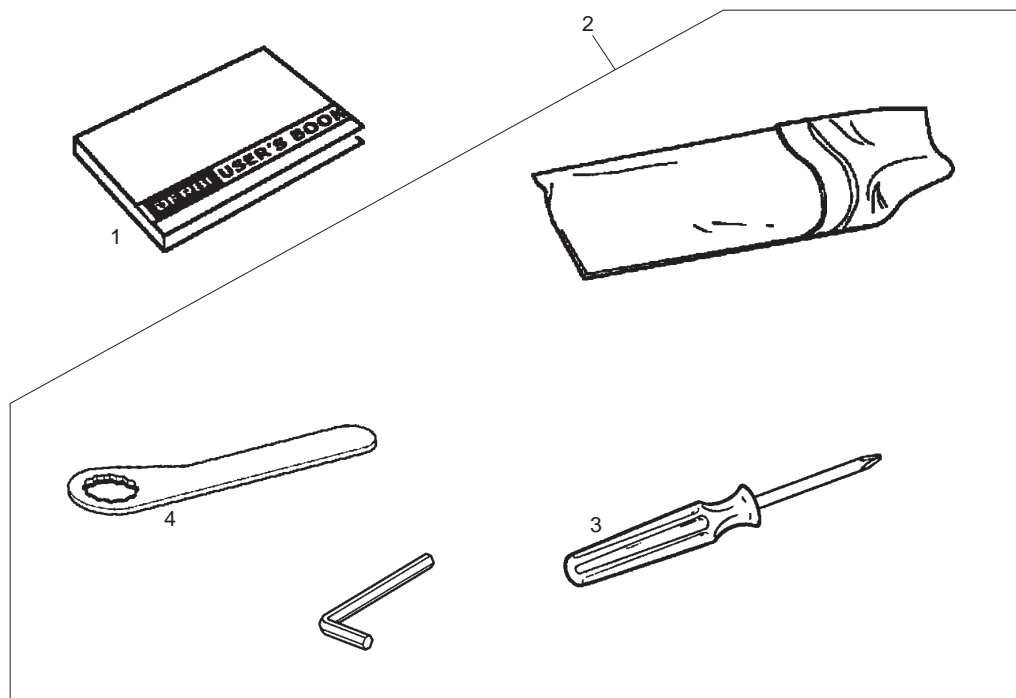

Fig.	Ver.	COD. KOD.	DESCRIPCIÓN DENOMINAZIONE NAME	BEZEICHNUNG DESIGNATION	MOD.	NOTAS NOTES NOTA MITSCHRIFT NOTES
01A		00H05160121	MANUAL INSTRUCCIONES LIBRETTI DI ISTRUZIONI USER'S BOOK	BEDIENUNGSANLEITUNG MANUEL D'INSTRUCTIONS	1 2 4 5 7 8	EXCEPT DENMARK
01B		861781	MANUAL INSTRUCCIONES DENMARK LIBRETTI DI ISTRUZIONI USER'S BOOK	BEDIENUNGSANLEITUNG MANUEL D'INSTRUCTIONS	2 5 8	ONLY DENMARK
01C		861781	MANUAL INSTRUCCIONES LIBRETTI DI ISTRUZIONI USER'S BOOK	BEDIENUNGSANLEITUNG MANUEL D'INSTRUCTIONS	3 6 9	
02A		00H05101561	CTO.BOLSA HERRTAS. SACCO FERRI TOOL POUCH	WERKZEUGTASCHE TROUSSE A OUTILS	1 2 3 4 5 6 7 8 9	
03A		00005551290	DESTORNILLADOR. CACCIAVITE SCREW DRIVER	SCHRAUBENZIEHER TOURNEVIS	1 2 3 4 5 6 7 8 9	
04A		00H05101011	SCTO.LLAVE BUJIA SUBCHIAVE CANDELA SE SPARK PLUG	ZUND KERZENSCHLUSSEL CLE A BOUGIE	1 2 3 4 5 6 7 8 9	

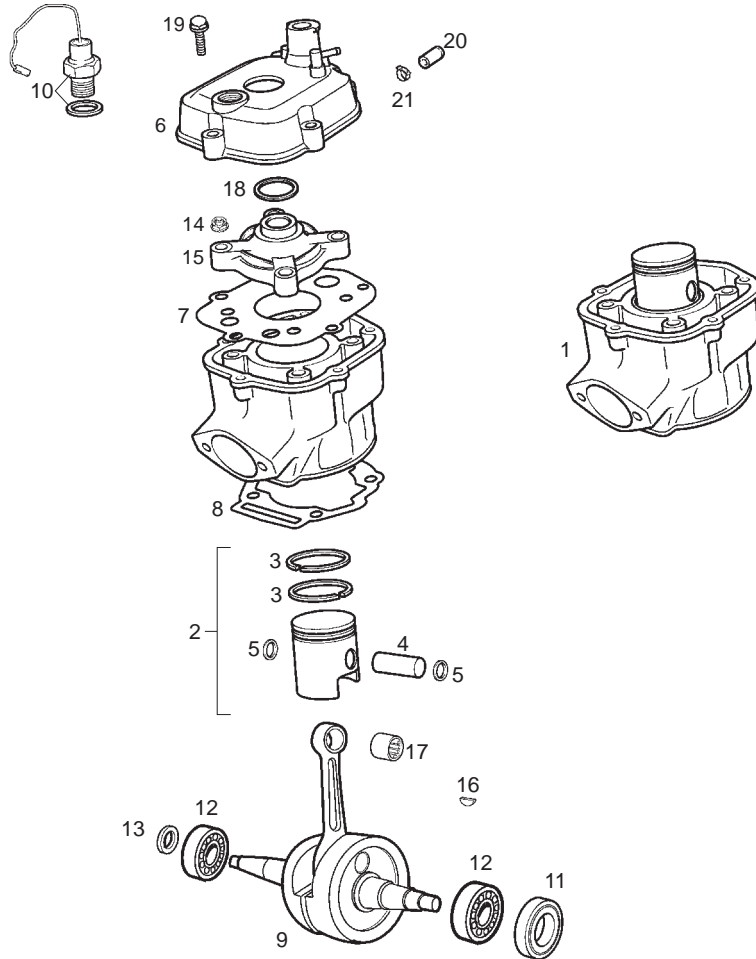

Fig.	Ver.	COD. KOD.	DESCRIPCIÓN DENOMINAZIONE NAME	BEZEICHNUNG DESIGNATION	MOD.	NOTAS NOTES NOTA MITSCHRIFT NOTES
01A		847508	R-CTO CILINDRO PISTON COMP.CILINDRO PISTONE CYLINDER PISTON ASSEMBLY	ZYLINDER UND KOLBEN CYLINDRE ET PISTON COMPLET	1 2 3 4 5 6 7 8 9	
02A		8472625001	CTO. PISTON (A) PISTONE (A) PISTON (A)	KOLBEN KOMPL.(A) PISTON-COMPLET (A)	1 2 3 4 5 6 7 8 9	
02B		8472625002	CTO. PISTON (B) PISTONE (B) PISTON (B)	KOLBEN KOMPL. (B) PISTON-COMPLET (B)	1 2 3 4 5 6 7 8 9	
02C		8472625003	CTO. PISTON (C) PISTONE (C) PISTON (C)	KOLBEN KOMPL. (C) PISTON-COMPLET (C)	1 2 3 4 5 6 7 8 9	
02D		8472625004	CTO. PISTON (D) PISTONE (D) PISTON (D)	KOLBEN KOMPL. (D) PISTON-COMPLET (D)	1 2 3 4 5 6 7 8 9	
03A		847006	R-ARO PISTON.SENDA R-SEGMENTO PISTONE PISTON RING	KOLBENDICHTRING SEGMENT DE PISTON	1 2 3 4 5 6 7 8 9	
04A		847012	R-BULON PISTON SPINOTTO PISTONE PISTON PIN	KOLBENBOLZEN AXE PISTON	1 2 3 4 5 6 7 8 9	
05A		847178	R-ANILLO BULON R-SEGMENTO SPINOTTO CIRCLIP, PISTON PIN	SICHERUNGSRING CLIPS AXE PISTON	1 2 3 4 5 6 7 8 9	
06A		CM151902	TAPA CULATIN COPERCHIO TESTA CYLINDER HEAD COVER	ZYLINDERKOPF DECKEL COUVERCLE CULASSE	1 2 3 4 5 6 7 8 9	
07A		847009	JUNTA CULATA CILINDRO GUARNIZIONE TESTA GASKET CYLINDER HEAD	ZYLINDERKOPFDICHTUNG JOINT DE CULASSE	1 2 3 4 5 6 7 8 9	
08A		847014	JUNTA CILINDRO GUARNIZIONE CILINDRO GASKET, CYLINDER	ZYLINDERPUBDICHTUNG JOINT DE CYLINDRE	1 2 3 4 5 6 7 8 9	

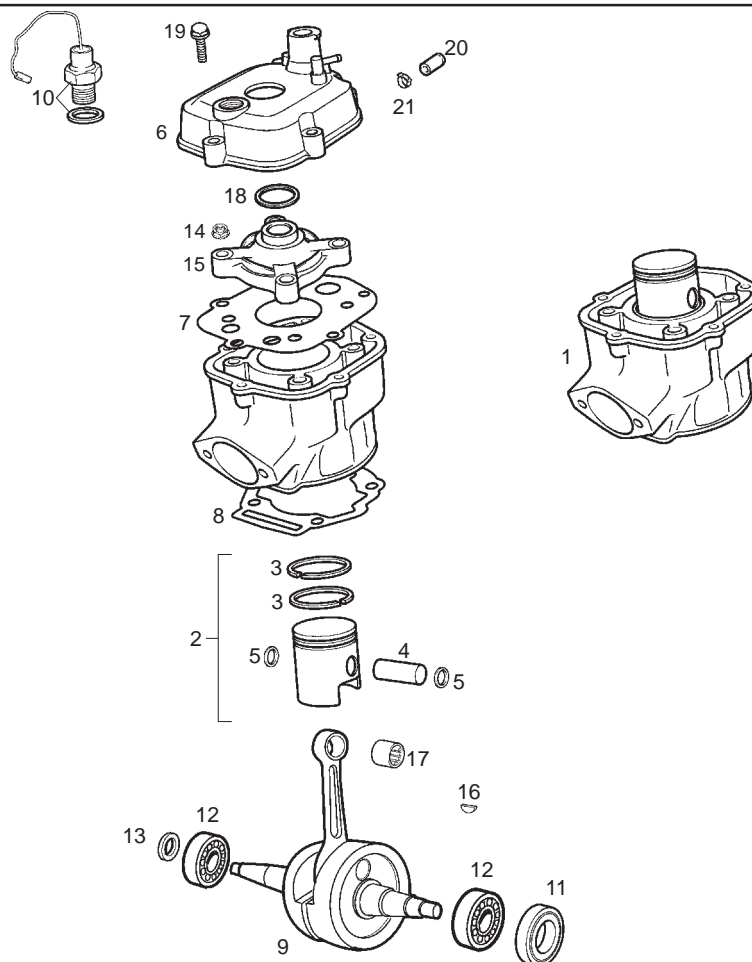

Fig.	Ver.	COD. KOD.	DESCRIPCIÓN DENOMINAZIONE NAME	BEZEICHNUNG DESIGNATION	MOD.	NOTAS NOTES NOTA MITSCHRIFT NOTES
09A		847026	CTO CIGÜEÑAL-BIELA ALBERO MOTORE CRANK SHAFT ROD	KURBELWELLE VILEBREQUIN COMPLET	1 2 3 4 5 6 7 8 9	
10A		847010	TERMOCONTACTO TERMOCONTATTO TERMOCONTACT	THERMOKONTAKT TERMOCONTATTO	1 2 3 4 5 6 7 8 9	
11A		847020	RETEN CIGUEÑAL GIUNTO TENUTA SEAL	DICHTRING JOINT	1 2 3 4 5 6 7 8 9	
12A		847172	COJINETE CUSCINETTO BEARING	LAGER COUSSINET	1 2 3 4 5 6 7 8 9	
13A		847020	RETEN CIGUEÑAL GIUNTO TENUTA SEAL	DICHTRING JOINT	1 2 3 4 5 6 7 8 9	
14A		436947	TUERCA EXAGONAL C/BRIDA 7M100 DADO NUT	MUTTER ECROU	1 2 3 4 5 6 7 8 9	
15A		847008	CULATIN TESTA CYLINDER HEAD	ZYLINDERKOPF CULASSE	1 2 3 4 5 6 7 8 9	
16A		847215	CHAVETA VOLANTE MAGNETICO SPINA KEY	KEIL CLAVETTE	1 2 3 4 5 6 7 8 9	
17A		847529	JAULA PIE BIELA GABBIA PIEDE BIELLA BEARING, PISTON PIN	NADELLAGER CAGE A AIGUILLE DE PIED DE	1 2 3 4 5 6 7 8 9	
18A		847007	JUNTA TORICA CULATIN GUARNIZIONE TESTA GASKET CYLINDER HEAD	ZYLINDERKOPFDICHTUNG JOINT DE CULASSE	1 2 3 4 5 6 7 8 9	
19A		CM149804	TORNILLO FIJACION TAPA 6X25 VITE SCREW	SCHRAUBE VIS	1 2 3 4 5 6 7 8 9	

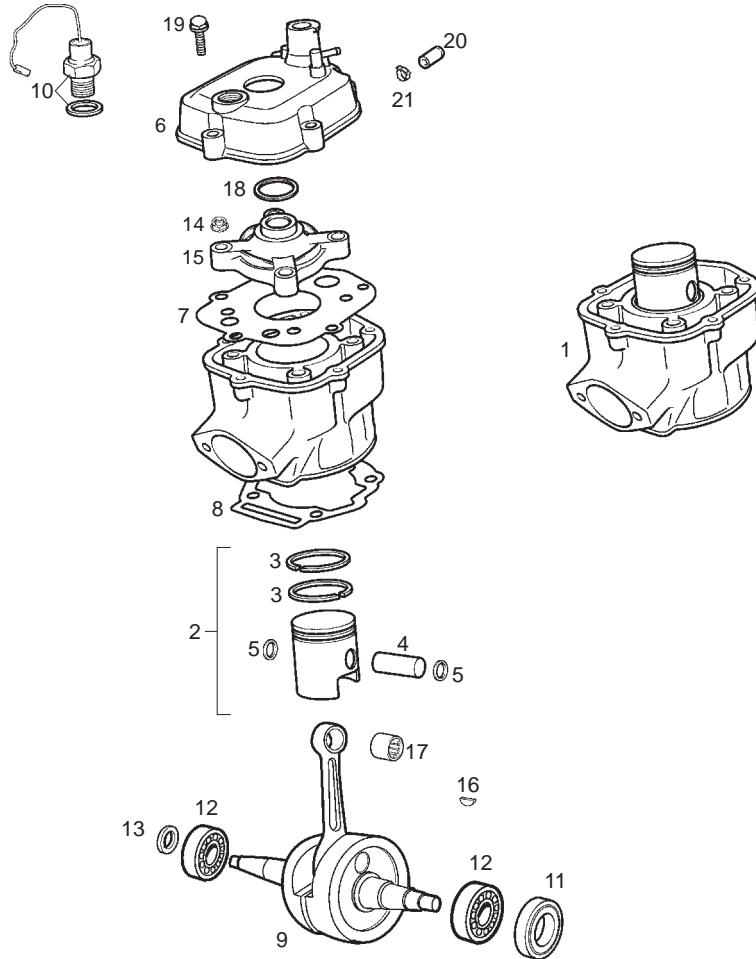

Fig.	Ver.	COD. KOD.	DESCRIPCIÓN DENOMINAZIONE NAME	BEZEICHNUNG DESIGNATION	MOD.	NOTAS NOTES NOTA MITSCHRIFT NOTES
20A		00H05001411	TAPON RACORD CULATA TAPO CAP	KAPPE BOUCHON	3 6 9	
21A		00F03700131	ABRAZADERA FIJACION FASCETTA CLAMP	FLANGE BRIDE	3 6 9	

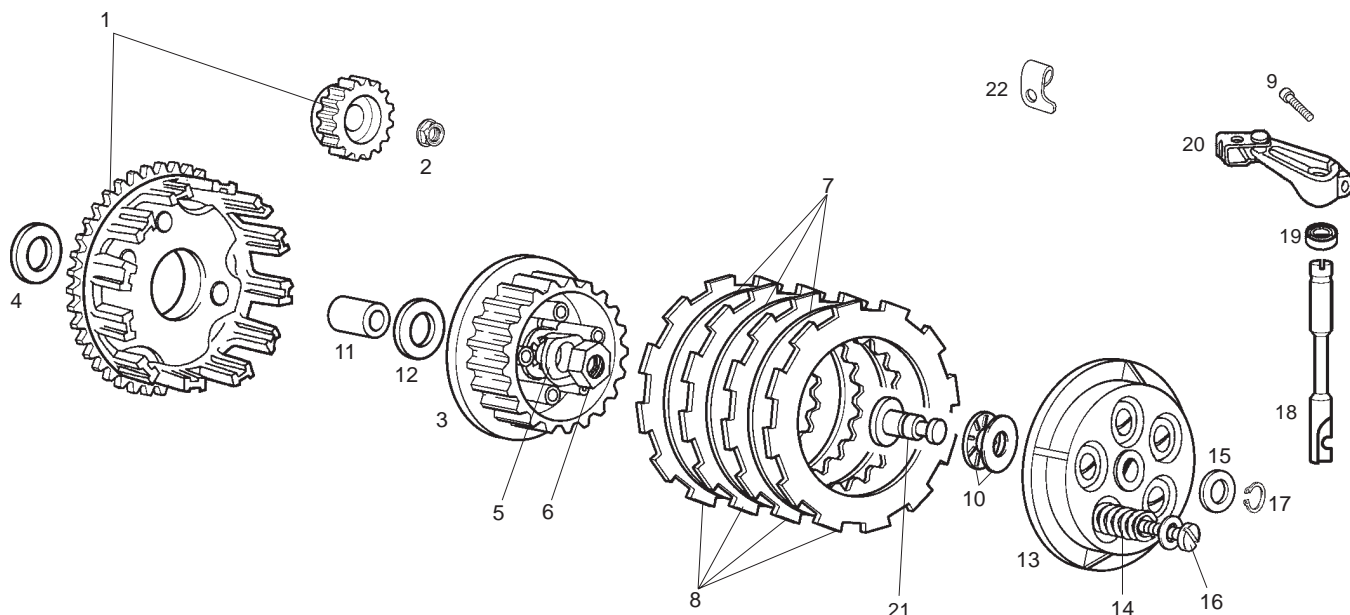

Fig.	Ver.	COD. KOD.	DESCRIPCIÓN DENOMINAZIONE NAME	BEZEICHNUNG DESIGNATION	MOD.	NOTAS NOTES NOTA MITSCHRIFT NOTES
01A		847098	CTO. RUEDA AMORT. EMBRAGUE R-RUOTA FRIZIONE CLUTCH HOUSING AND DAMPER	KUPPLUNGSRAD CLOCHE EMBRAYAGE AVEC PIGNO	1 2 3 4 5 6 7 8 9	
02A		847217	TUERCA C/BASE 10M100 DADO NUT	MUTTER ECROU	1 2 3 4 5 6 7 8 9	
03A		847045	CAMPANA CONDUCIDA CAMPANA GUIDATA CLUTCH HUB.	GLOCKE TAMBOUR EMBRAYAGE	1 2 3 4 5 6 7 8 9	
04A		847218	ARANDELA PROTEC.INT.BUJE EMBRAG. RONDELLA WASHER	SCHEIBE RONDELLE	1 2 3 4 5 6 7 8 9	
05A		847220	PRECTO.TCA.EMBRG. PIASTRINA DADO FRIZIONE WASHER, RETAINING	SICHERUNG FREIN DIECROU DIEMBAYAGE	1 2 3 4 5 6 7 8 9	
06A		847221	TUERCA EMBRAGUE DADO NUT	MUTTER ECROU	1 2 3 4 5 6 7 8 9	
07A		847043	DISCO CONDUCIDO DISCO GUIDATO DRIVEN CLUTCH PLATE	SCHEIBE DISQUE EMBRAYAGE LISSE	1 2 3 4 5 6 7 8 9	
08A		847044	SCTO.DISCO CONDUCTOR SUBDISCO GUIDA CLUTCH PLATE	KUPPLUNGSRELAG DISQUE EMBRAYAGE GARNI	1 2 3 4 5 6 7 8 9	
09A		847179	TORNILLO 6M100X20 VITE SCREW	SCHRAUBE VIS	1 2 3 4 5 6 7 8 9	
10A		82835R	RODAMTO.AXIAL CREMALL.EMBRG. CUSCINETTO SFERE RADIALE CREMA BALL BEARING	LAGER ROULEMENT AXIAL	1 2 3 4 5 6 7 8 9	
11A		847040	CASQUILLO BUJE EMBRAGUE GHIERA BRONZINA FRIZIONE BUSHING	FUHRUNGSBUCHSE GABELSCHENK ENTRETOISE	1 2 3 4 5 6 7 8 9	

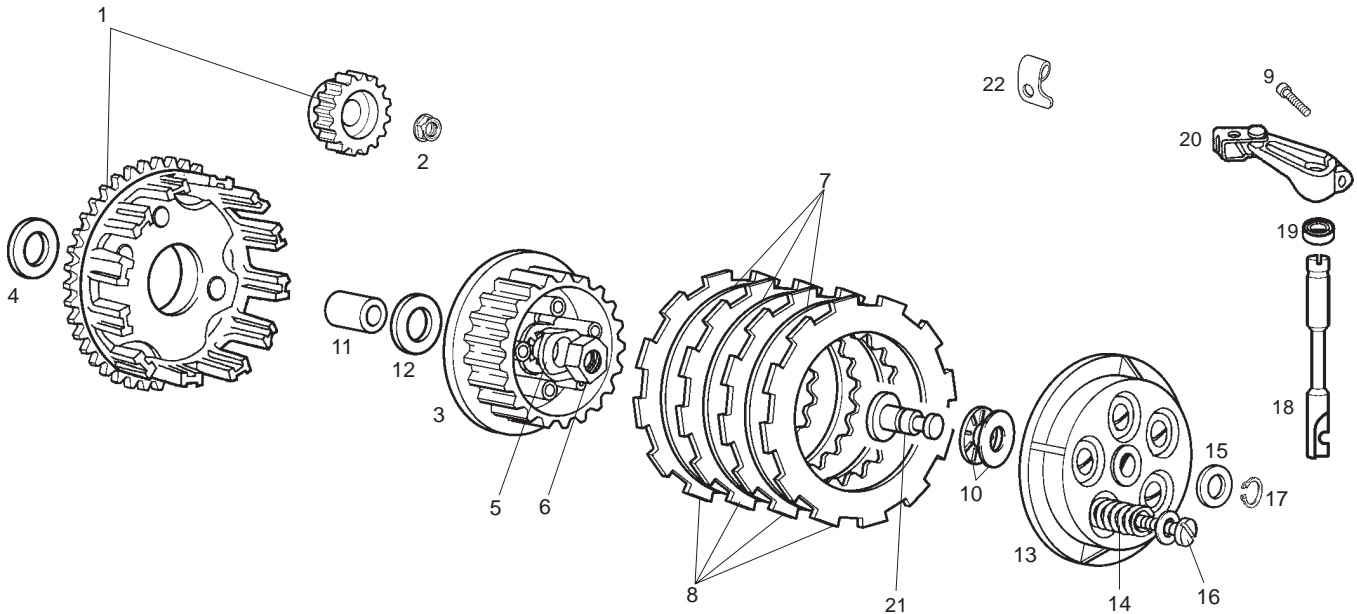

Fig.	Ver.	COD. KOD.	DESCRIPCIÓN DENOMINAZIONE NAME	BEZEICHNUNG DESIGNATION	MOD.	NOTAS NOTES NOTA MITSCHRIFT NOTES
12A		847042	ARANDELA ROZAMTO.CAMPANA. RONDELLA WASHER	SCHEIBE RONDELLE	1 2 3 4 5 6 7 8 9	
13A		847046	TAPA CIERRE EMBRAG COPERCHIO CHIUSURA FRIZIONE G. OUTER CLUTCH PLATE	KUPPLINGS-VERSCHLUSSECKEL PLATEAU EXTERIEUR D,EMBRAYA	1 2 3 4 5 6 7 8 9	
14A		847047	MUELLE REGULAC. EMBRAGUE MOLLA REGOLAZIONE FRIZIONE CLUTCH SPRING	STELLFEDER RESORT REGLAGE	1 2 3 4 5 6 7 8 9	
15A		847224	ARANDELA TOPE PIÑON INTERMD. RONDELLA WASHER	SCHEIBE RONDELLE	1 2 3 4 5 6 7 8 9	
16A		847048	SCTO. TORNILLO 5M80X35 VITE SCREW	SCHRAUBE VIS	1 2 3 4 5 6 7 8 9	
17A		847225	ANILLO SEGURIDAD ANELLO SICUREZZA CIRCLIP	SEEGERRING CIRCLIP	1 2 3 4 5 6 7 8 9	
18A		847083	EJE DESEMBRAGUE ASSE DISINNESCO FRIZIONE CLUTCH SHAFT	KUPPLUNGSACHSE AXE	1 2 3 4 5 6 7 8 9	
19A		847075	RETEN EJE MANDO GIUNTO TENUTA SEAL	DICHTRING JOINT	1 2 3 4 5 6 7 8 9	
20A		CM151201	SCTO.PALANCA DESEMBRAGUE SUBLEVA DISINNESCO F CLUTCH LEVER	KUPPLUNGSHEBEL LEVIER EMBRAYAGE	1 2 3 4 5 6 7 8 9	
21A		847223	DESPLAZABLE EMBRAGUE ASSE FRIZIONE CLUTCH SHAFT	KUPPLUNGSACHSE AXE	1 2 3 4 5 6 7 8 9	
22A		847090	PLACA TENSOR CABLE EMBRAGUE PIASTRINA PLATE	PLATTE PLAQUE	1 2 3 4 5 6 7 8 9	

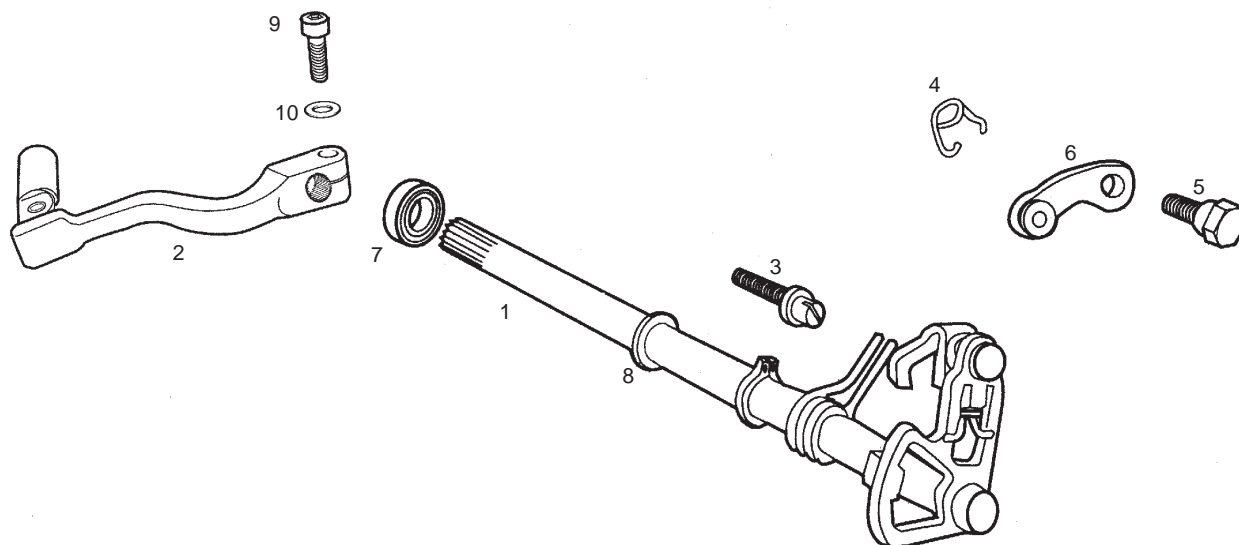

Fig.	Ver.	COD. KOD.	DESCRIPCIÓN DENOMINAZIONE NAME	BEZEICHNUNG DESIGNATION	MOD.	NOTAS NOTES NOTA MITSCHRIFT NOTES
01A		847236	EJE SELECTOR SUBASSE SELETTORE S-ASSY. SELECTOR SHAFT	SCHALTACHSE S-ENSEMBLE AXE SELECTEUR	1 2 3 4 5 6 7 8 9	
02A		00H02703421	CTO PALANCA CAMBIO LEVA CAMBIO GEARSHIFT ASSY.	GRUPPE GANGSCHALTHEBEL PEDALE DE SELECTEUR	1 2 3 4 5 6 7 8 9	
03A		847073	ESPARRAGO MUELLE SELECTOR BULLONE MOLLA SELETTORE SCREW, SELECTOR SPRING ADJ.	FEDERSTIFT AXE EXCENTRIQUE	1 2 3 4 5 6 7 8 9	
04A		847069	MUELLE FIJ.MARCHAS. MOLLA FISSAGGIO MARCE GEAR FIXING SPARING	BEF.-FEDER RESSORT	1 2 3 4 5 6 7 8 9	
05A		847070	TORNILLO GUIA FIJ.MARCHAS VITE SCREW	SCHRAUBE VIS	1 2 3 4 5 6 7 8 9	
06A		847068	SCTO.PALANCA FIJ.MARCHAS. SUBLEVA FISSAGGIO MA LEVER FIXING GEARS	GANSCHALTHEEEL LEVIER FIXATION PIGNONS	1 2 3 4 5 6 7 8 9	
07A		847075	RETEN EJE MANDO RICHIAMO ASSE COMANDO SELETTOR OIL SEAL, SELECTOR SHAFT	SIMMERRING JOINT ANTI-FUITE	1 2 3 4 5 6 7 8 9	
08A		847228	ARANDELA SEGURO TAMBOR RONDELLA WASHER	SCHEIBE RONDELLE	1 2 3 4 5 6 7 8 9	
09A		00002062511	TORNILLO C/ALLEN 6M100X25 VITE SCREW	SCHRAUBE VIS	1 2 3 4 5 6 7 8 9	
10A		00442060002	ARANDELA MUELLE D6 RONDELLA WASHER	SCHEIBE RONDELLE	1 2 3 4 5 6 7 8 9	

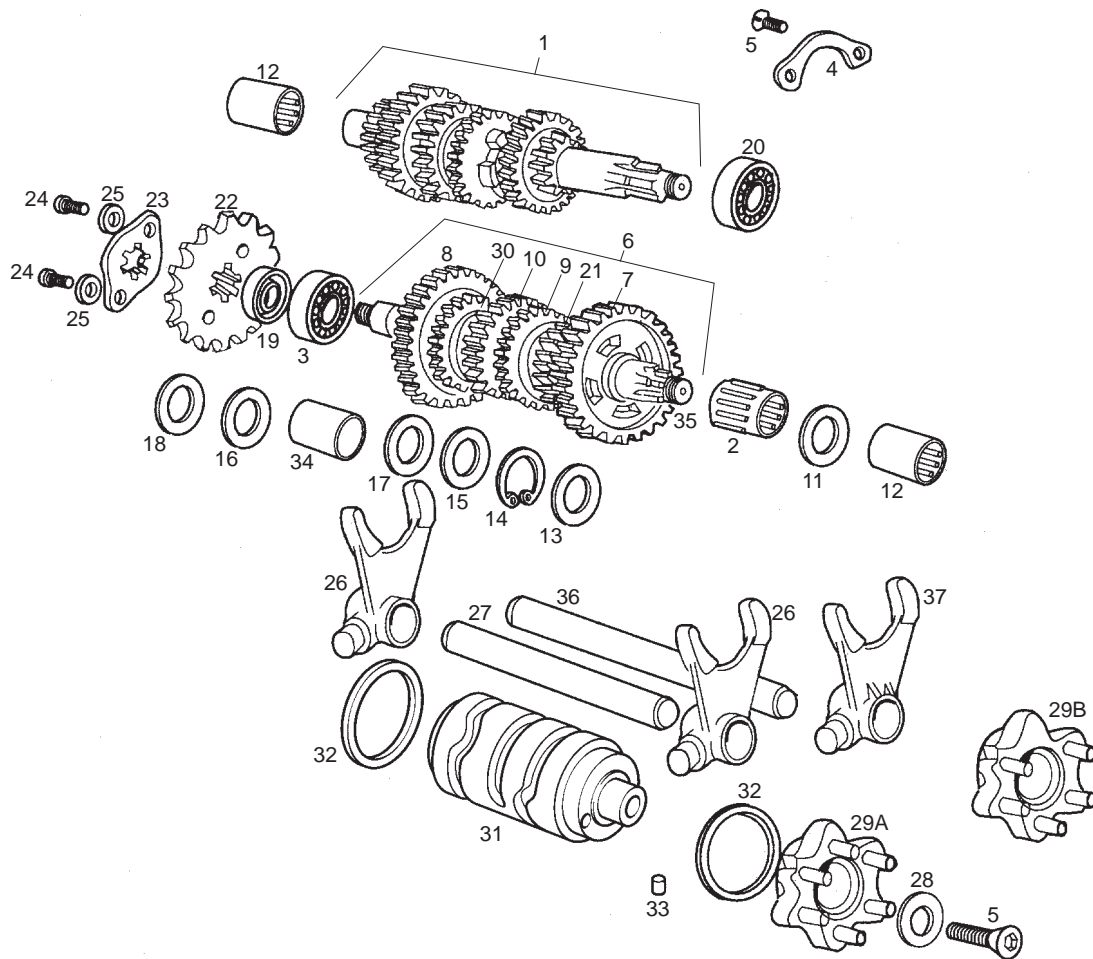

Fig.	Ver.	COD. KOD.	DESCRIPCIÓN DENOMINAZIONE NAME	BEZEICHNUNG DESIGNATION	MOD.	NOTAS NOTES NOTA MITSCHRIFT NOTES
01A		847027	SCTO. EJE PRIMARIO 6V SUBASSE PRIMARIO DRIVE SHAFT.	PRIMARCHSE AXE PRIMAIRE	1 2 3 4 5 6 7 8 9	
02A		847544	CORONA AGUJAS PIÑON CORONA RULLINI PIGNONE NEEDLE BEARING	BADELLGER ROULEMENT AIGUILLES	1 2 3 4 5 6 7 8 9	
03A		847086	COJINETE CUSCINETTO BEARING	LAGER COUSSINET	1 2 3 4 5 6 7 8 9	
04A		847021	PRECINTO COJINETE EJE PRIMARIO PIASTRINA CUSCINETTO ASSE PRIM PLATE POSITION BALL BEARINGS	KUGELLEGERPRIMDRACHSE BUTEE DE ROULEMENT	1 2 3 4 5 6 7 8 9	
05A		847210	TORNILLO AV.ALL.5M80X10 VITE SCREW	SCHRAUBE VIS	1 2 3 4 5 6 7 8 9	
06A		847028	CTO. EJE SECUNDARIO 6V ASSE SECONDARIO OUTPUT SHAFT	SEKUNDRACHSE AXE SECONDAIRE MONTE COMPLE	1 2 3 4 5 6 7 8 9	
07A		847153	PIÑON SECUNDARIO I Z-34 PIGNONE GEAR	RITZEL PIGNON	1 2 3 4 5 6 7 8 9	
08A		847157	PIÑON SECUNDARIO II Z-30 PIGNONE GEAR	RITZEL PIGNON	1 2 3 4 5 6 7 8 9	
09A		847155	PIÑON SECUNDARIO III Z-27 PIGNONE GEAR	RITZEL PIGNON	1 2 3 4 5 6 7 8 9	
10A		847156	PIÑON SECUNDARIO IV Z-24 PIGNONE GEAR	RITZEL PIGNON	1 2 3 4 5 6 7 8 9	
11A		847549	ARANDELA REGLAJE EJE SECUNDARIO RONDELLA WASHER	SCHEIBE RONDELLE	1 2 3 4 5 6 7 8 9	

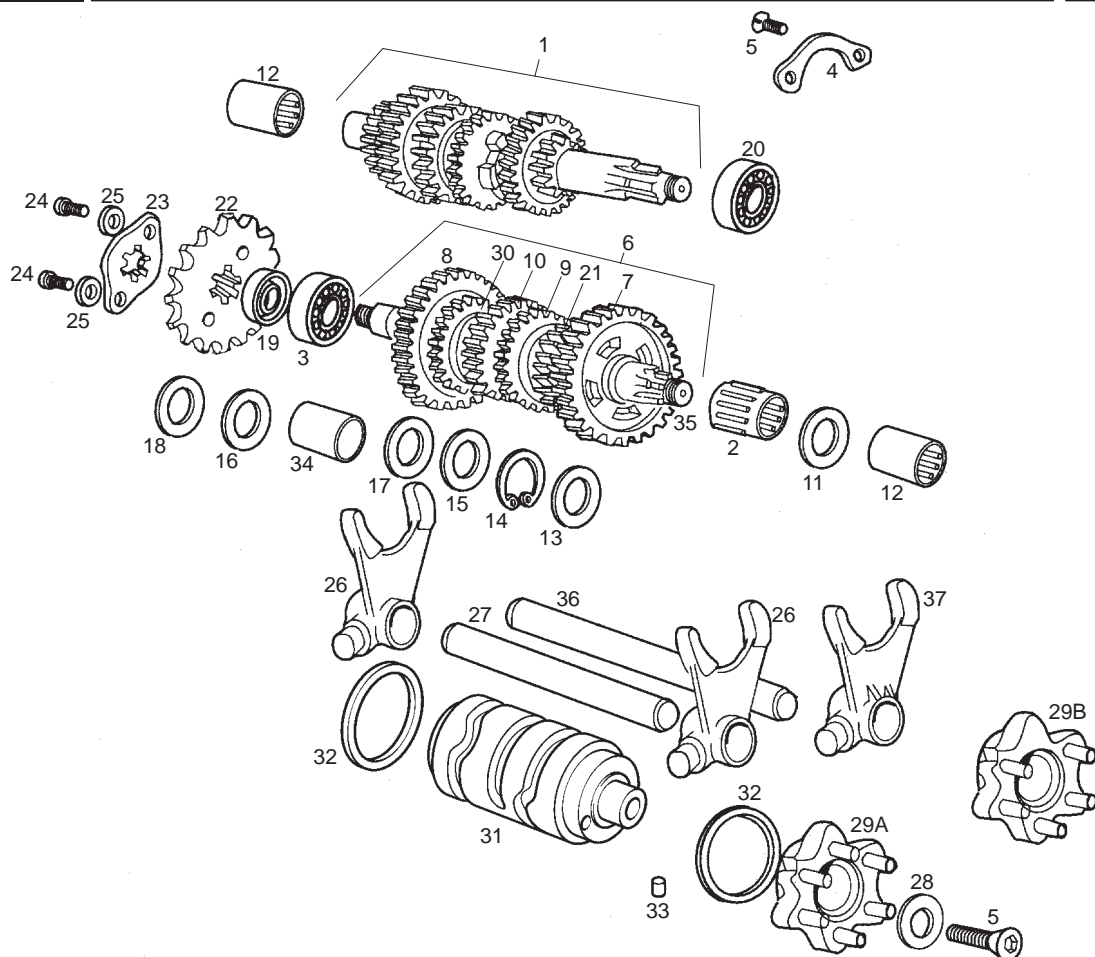

Fig.	Ver.	COD. KOD.	DESCRIPCIÓN DENOMINAZIONE NAME	BEZEICHNUNG DESIGNATION	MOD.	NOTAS NOTES NOTA MITSCHRIFT NOTES
12A		847211	CASQUILLO AGUJAS GHIERA RULLINI NEEDLE BEARING	NADELLGER CAGE A AIGUILLES	1 2 3 4 5 6 7 8 9	
13A		847550	ARANDELA ROZAMTO.PIÑON SECUND.I RONDELLA WASHER	SCHEIBE RONDELLE	1 2 3 4 5 6 7 8 9	
14A		847542	ANILLO SEGURIDAD ANELLO SICUREZZA CIRCLIP	SEEGERRING CIRCLIP	1 2 3 4 5 6 7 8 9	
15A		847548	ARANDELA RONDELLA WASHER	SCHEIBE RONDELLE	1 2 3 4 5 6 7 8 9	
16A		847541	ARANDELA RONDELLA WASHER	SCHEIBE RONDELLE	1 2 3 4 5 6 7 8 9	
17A		847546	ARANDELA RONDELLA WASHER	SCHEIBE RONDELLE	1 2 3 4 5 6 7 8 9	
18A		847545	ARANDELA RONDELLA WASHER	SCHEIBE RONDELLE	1 2 3 4 5 6 7 8 9	
19A		847019	RETEN.PIÑON SALIDA CAMBIO GIUNTO TENUTA SEAL	DICHTRING JOINT	1 2 3 4 5 6 7 8 9	
20A		847209	COJINETE CUSCINETTO BEARING	LAGER COUSSINET	1 2 3 4 5 6 7 8 9	
21A		847154	PIÑON SECUNDARIO V Z-23 PIGNONE GEAR	RITZEL PIGNON	1 2 3 4 5 6 7 8 9	
22A		00H02813371	PIÑON SALIDA CAMBIO Z-11 PIGNONE GEAR	RITZEL PIGNON	1 2 4 5 7 8	

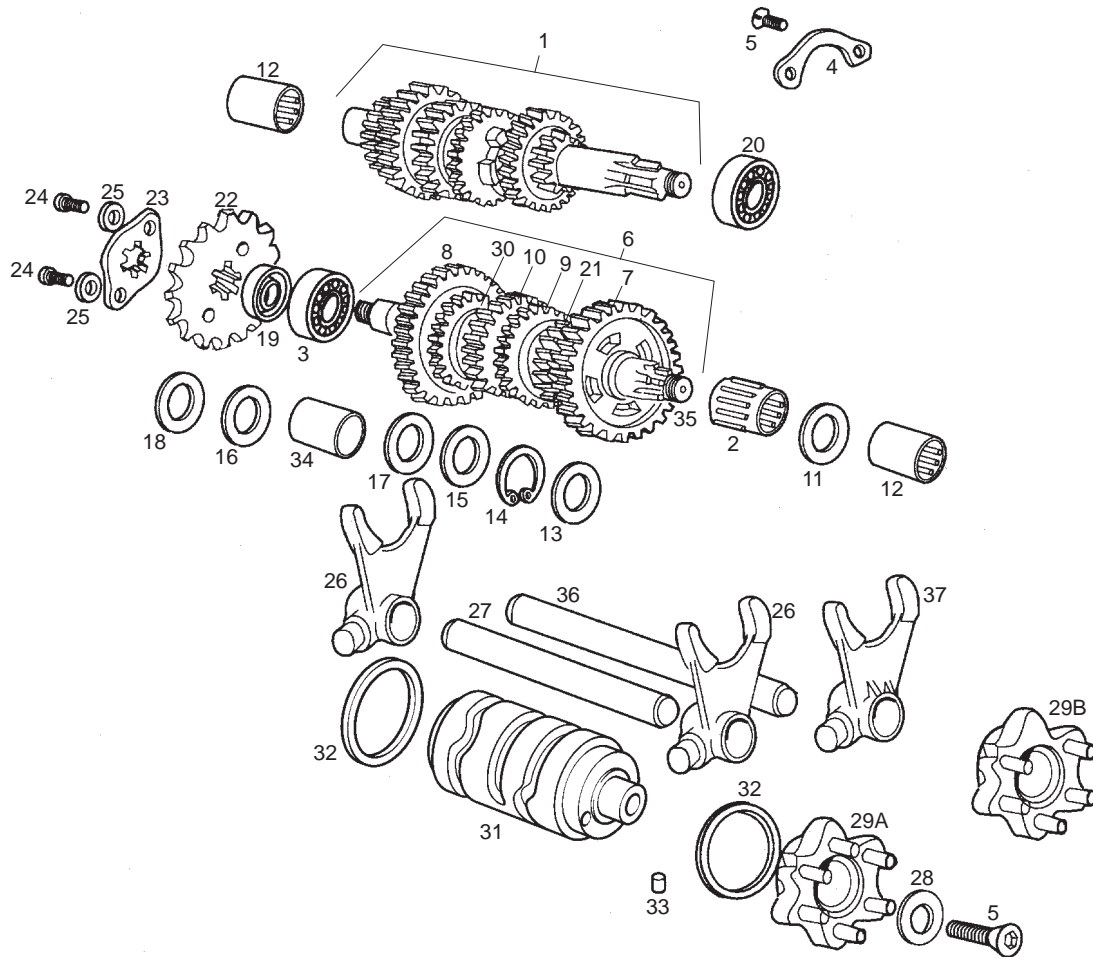

Fig.	Ver.	COD. KOD.	DESCRIPCIÓN DENOMINAZIONE NAME	BEZEICHNUNG DESIGNATION	MOD.	NOTAS NOTES NOTA MITSCHRIFT NOTES
22B		00H02808371	PIÑÓN SALIDA CAMBIO Z-12 PIGNONE GEAR	RITZEL PIGNON	3 6 9	
23A		00H02800421	PRECINTO PIÑÓN SALIDA CAMBIO PIASTRINA PIGNONE USCITA CAMBI LOCKWASHER, COUNTERSHAFT SPROK	HALTER RONDELLE DE SECURITE SBV.	1 2 4 5 7 8	
23B		00H02810421	PRECINTO PIÑÓN SALIDA CAMBIO PIASTRINA PIGNONE USCITA CAMBI LOCKWASHER, COUNTERSHAFT SPROK	HALTER RONDELLE DE SECURITE SBV.	3 6 9	
24A		00002041050	TORNILLO C/ALLEN 4M70X10 VITE SCREW	SCHRAUBE VIS	1 2 4 5 7 8	
24B		00000004510	TORNILLO C/ALLEN 5M80X10 VITE SCREW	SCHRAUBE VIS	3 6 9	
25A		00000033040	ARANDELA MUELLE D4 RONDELLA WASHER	SCHEIBE RONDELLE	1 2 4 5 7 8	
25B		00000034050	ARANDELA ESTRELLA INT D5 RONDELLA WASHER	SCHEIBE RONDELLE	3 6 9	
26A		847032	HORQUILLA SECUNDARIA FORCELLA SECONDARIA FORK OUTPUT	SHALTGABEL FOURCHETTE	1 2 3 4 5 6 7 8 9	
27A		847030	EJE HORQUILLA SECUNDARIA ASSE FORCELLA SECONDARIA SECONDARY FORK SHAFT	GABEL SEKUNDARACHSE AXE	1 2 3 4 5 6 7 8 9	
28A		847214	ARANDELA PIÑ.CONTR/MAND.TAMBOR RONDELLA WASHER	SCHEIBE RONDELLE	1 2 3 4 5 6 7 8 9	
29A		847038	CABEZA MANDO TAMBOR TESTA COMANDO TAMBORO DRUM HEAD	ESTEUERKOPF TETE TAMBOR SELECTEUR	1 2 3 4 5 6 7 8 9	EXCEPT DENMARK

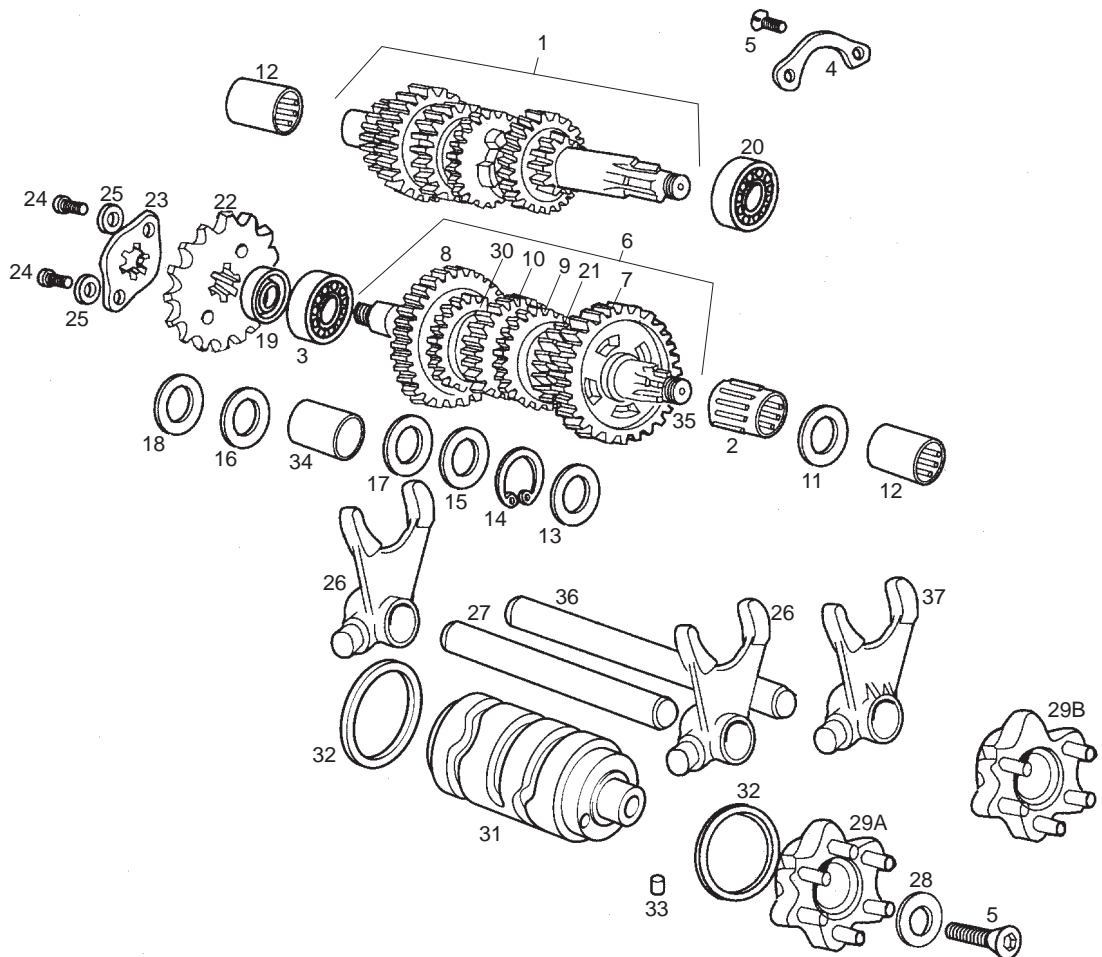

Fig.	Ver.	COD. KOD.	DESCRIPCIÓN DENOMINAZIONE NAME	BEZEICHNUNG DESIGNATION	MOD.	NOTAS NOTES NOTA MITSCHRIFT NOTES
29B		863136	CABEZA MANDO TAMBOR DENM. 30 KMH TESTA COMANDO TAMBORO DRUM HEAD	ESTEUERKOPF TETE TAMBOUR SELECTEUR	2 5 8	ONLY DENMARK
30A		847158	PIÑÓN SECUNDARIO VI Z-22 PIGNONE GEAR	RITZEL PIGNON	1 2 3 4 5 6 7 8 9	
31A		847081	TAMBOR DISTRIBUIDOR TAMBORO DISTRIBUTORE SHIFT DRUM	VERTEILERTROMMEL BARILLET	1 2 3 4 5 6 7 8 9	
32A		847036	ARANDELA TAMBOR DISTRIBUIDOR RONDELLA WASHER	SCHEIBE RONDELLE	1 2 3 4 5 6 7 8 9	
33A		847213	RODILLO.4X6. RULLO ROLLER	WALZE FUR SCHA LTUNG GALETS	1 2 3 4 5 6 7 8 9	
34A		847547	CASQUILLO PIÑÓN SECUND.II. GHIERA PIGNONE SECONDARIO .II. BUSHING	FUHRUNGSBUCHSE GABELSCHENK ENTRETOISE	1 2 3 4 5 6 7 8 9	
35A		847159	SCTO EJE SECUNDARIO 6V. ASSE SECONDARIO OUTPUT SHAFT	SEKUNDARACHSE AXE SECONDAIRE MONTE COMPLE	1 2 3 4 5 6 7 8 9	
36A		847029	EJE HORQUILLA PRIMARIA. ASSE FORCELLA PRIMARIA PRIMARY FORK SHAFT	GABEL PRIMARACHSE AXE	1 2 3 4 5 6 7 8 9	
37A		847031	HORQUILLA PRIMARIA V-VI. FORCELLA PRIMARIA FORK OUTPUT	SHALTGABEL FOURCHETTE	1 2 3 4 5 6 7 8 9	

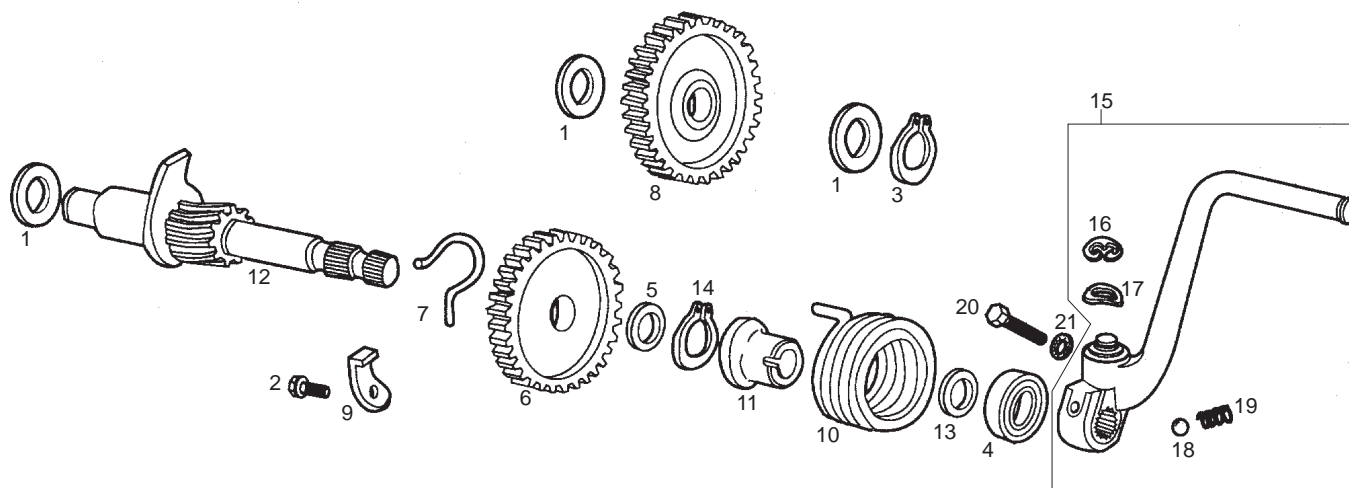

Fig.	Ver.	COD. KOD.	DESCRIPCIÓN DENOMINAZIONE NAME	BEZEICHNUNG DESIGNATION	MOD.	NOTAS NOTES NOTA MITSCHRIFT NOTES
01A		847228	ARANDELA RONDELLA WASHER	SCHEIBE RONDELLE	1 2 3 4 5 6 7 8 9	
02A		CM149802	TORNILLO FIJ.TOPE ARRANQUE VITE SCREW	SCHRAUBE VIS	1 2 3 4 5 6 7 8 9	
03A		847229	ANILLO SEGURIDAD D11 ANELLO SICUREZZA CIRCLIP	SEEGERRING CIRCLIP	1 2 3 4 5 6 7 8 9	
04A		847074	RETEN EJE ARRANQUE GIUNTO TENUTA SEAL	DICHTRING JOINT	1 2 3 4 5 6 7 8 9	
05A		847232	ARANDELA TOPE PIÑON ARRANQUE RONDELLA WASHER	SCHEIBE RONDELLE	1 2 3 4 5 6 7 8 9	
06A		847061	PIÑON ARRANQUE Z-29 PIGNONE AVVIAMENTO KICKSTARTER GEAR	ANLAUFTRITZEL ROUE DE MISE EN MARCHÉ	1 2 3 4 5 6 7 8 9	
07A		847060	MUELLE PIÑON ARR. MOLLA PIGNONE AVVIAMENTO SPRING, ENGAGEMENTE REAR	RITZELFEDER RESSORT DE ROUE DE MISE EN	1 2 3 4 5 6 7 8 9	
08A		847056	PIÑON INTERMEDIO ARRANQUE PIGNONE INTERMEDIO AVVIAMENTO DRIVING GEAR	ANLAUF-ZWISCHENRITZEL ROUE INTERMEDIAIRE	1 2 3 4 5 6 7 8 9	
09A		847062	REFUERZO TOPE ARRANQUE RINFORZO FERMO AVVIAMENTO KICKSTARTER LEVER STOP	VERSTARUNG F.ANSCHULAG BUTEE PEDALE DE KICK	1 2 3 4 5 6 7 8 9	
10A		847057	MUELLE ARRANQUE, MOLLA AVVIAMENTO KICKSTARTER SPRING	ANLAUFFEDER RESSORT DE KICK	1 2 3 4 5 6 7 8 9	
11A		847058	CAZOLETA.GUIA MUELLE ARRANQUE SCODELLINO GUIDA MOLLA AVVIAMENTO SPRING GUIDE	FUHRUNGSPFANE RAMPE DE KICK	1 2 3 4 5 6 7 8 9	

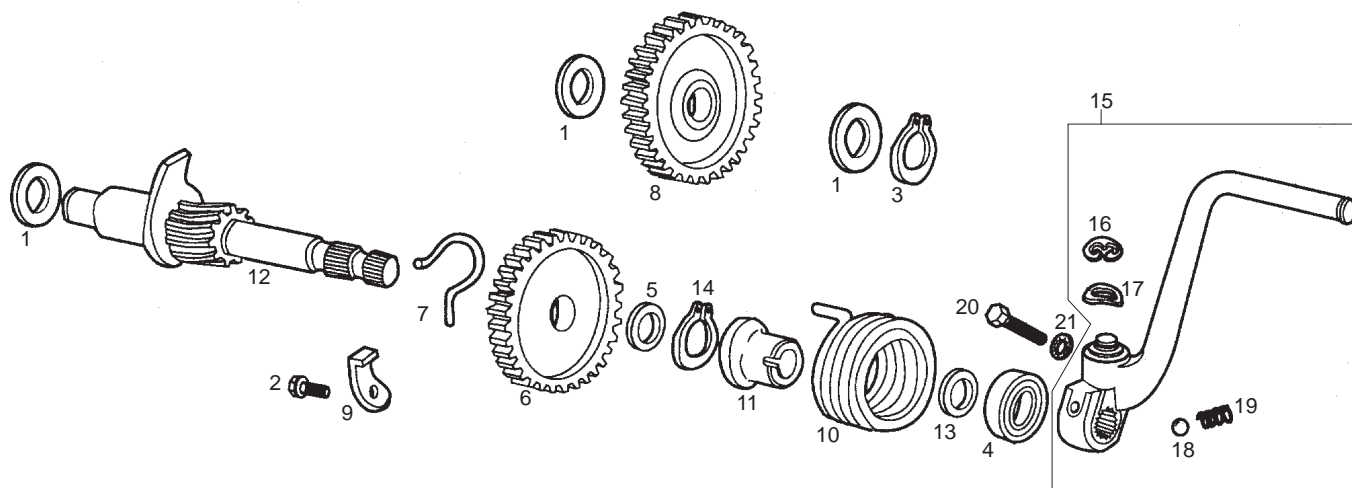

Fig.	Ver.	COD. KOD.	DESCRIPCIÓN DENOMINAZIONE NAME	BEZEICHNUNG DESIGNATION	MOD.	NOTAS NOTES NOTA MITSCHRIFT NOTES
12A		847059	SCTO.EJE ARRANQUE, SUBASSE AVVIAMENTO KICKSTARTER SHAFT	ANLAUFACHSE ARBRE DE KICK	1 2 3 4 5 6 7 8 9	
13A		847230	ARANDELA TOPE ARRANQUE RONDELLA WASHER	SCHEIBE RONDELLE	1 2 3 4 5 6 7 8 9	
14A		847231	ANILLO SEGURIDAD D22 ANELLO SICUREZZA CIRCLIP	SEEGERRING CIRCLIP	1 2 3 4 5 6 7 8 9	
15A		00H02902252	PALANCA ARRANQUE LEVA AVVIAMENTO KICKSTARTER LEVER	KICKSTARTER LEVIER DE KICK	1 2 3 4 5 6 7 8 9	
16A		00047030900	ANILLO SEGURIDAD ANELLO SICUREZZA CIRCLIP	SICHERHEITSRING ANNEAU SECURITE AXE	1 2 3 4 5 6 7 8 9	
17A		00000036100	ARANDELA MUELLE RONDELLA WASHER	SCHEIBE RONDELLE	1 2 3 4 5 6 7 8 9	
18A		00000061040	BOLA.D.4,76. PALLA BALL	KUGEL BILLE DIAMETRE	1 2 3 4 5 6 7 8 9	
19A		00003127200	MUELLE MOLLA GRILLETTO TORCIA SPRING, DETENT	FEDER RESSORT	1 2 3 4 5 6 7 8 9	
20A		00004162500	TORNILLO C/ALLEN 6M100X25 VITE SCREW	SCHRAUBE VIS	1 2 3 4 5 6 7 8 9	
21A		00037000600	ARANDELA CONICA SEG. D6 RONDELLA WASHER	SCHEIBE RONDELLE	1 2 3 4 5 6 7 8 9	

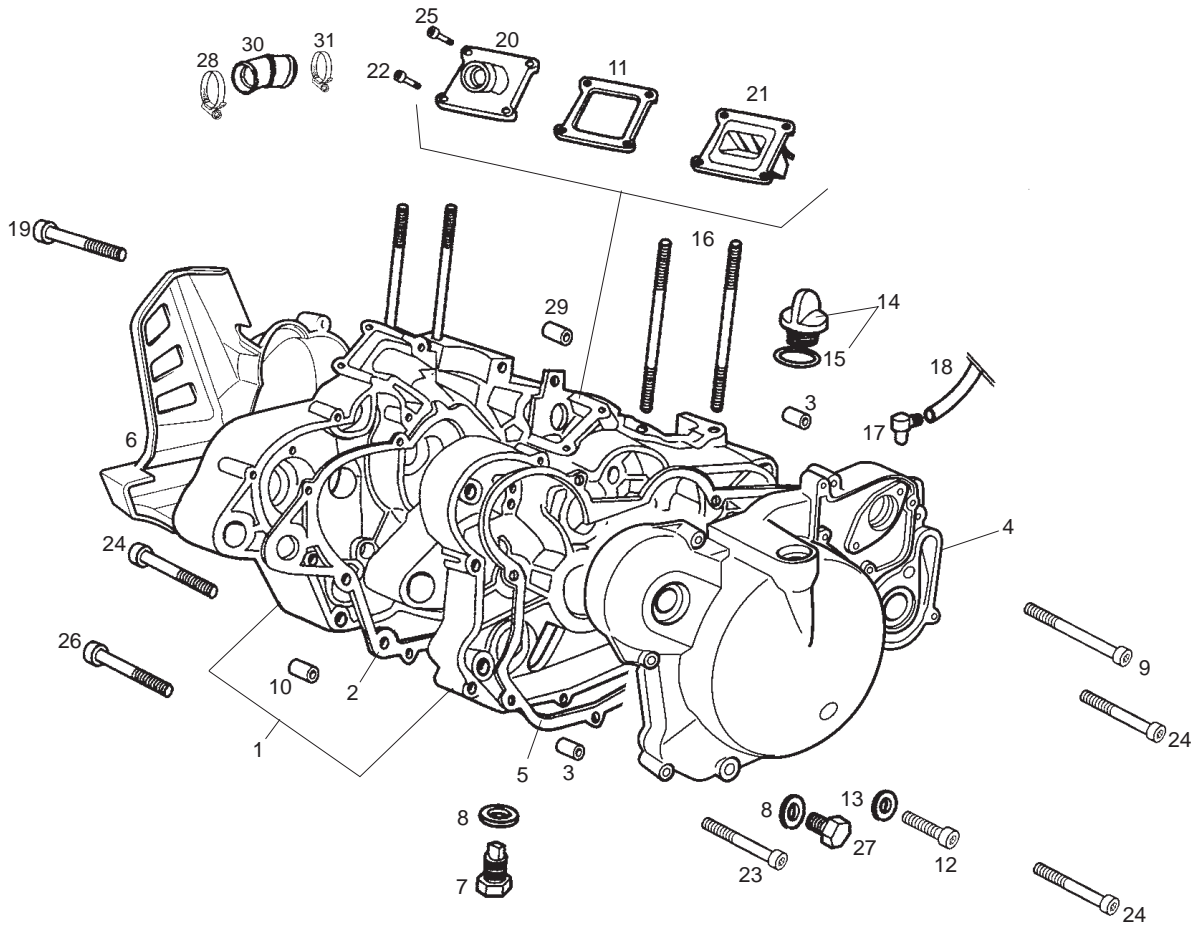

Fig.	Ver.	COD. KOD.	DESCRIPCIÓN DENOMINAZIONE NAME	BEZEICHNUNG DESIGNATION	MOD.	NOTAS NOTES NOTA MITSCHRIFT NOTES
01A		CM1503015	CTO. CARTERS CARTERS CRANCKASE ASSEMBLY	MOTORGEHAUSE ENSEMBLE DES CARTERS MOTEUR	1 2 3 4 5 6 7 8 9	
02A		847022	JUNTA CARTERS GUARNIZIONE CARTERS GASKET, CHANCKASE	GEHAUSEDICHTUNG JOINT DE CARTERS CENTRAUX	1 2 3 4 5 6 7 8 9	
03A		847241	PASADOR UNION CARTER. CHIAVISTELLO SOSTEGNO SPIRALE FORK PIN	STIFT GOUDILLE	1 2 3 4 5 6 7 8 9	
04A		CM150703	TAPA CARTER DERECHA SUBC.COP.CARTER DES. CRANCKASE COVER	KUPLINGSDECKEL CARTER DIEMBRAYAGE	1 2 3 4 5 6 7 8 9	
05A		847084	JUNTA TAPA CARTER DERECHA GUARNIZIONE COPERCHIO CARTER D GASKET RIGHT-HAND COVER	DICHTUNG JOINT DE CARTER EMBRAYAGE	1 2 3 4 5 6 7 8 9	
06A		00H03007241	TAPA CARTER IZQUIERDA COPERCHIO CARTER SINISTRO CRANCKASE COVER LEFT	GEHD US ED EDKELLINKS COUVERCLE CARTER GAUCHE	1 2 3 4 5 6 7 8 9	
07A		847237	CTO.TORNILLO VACIADO.ACEITE VITE SCREW	SCHRAUBE VIS	1 2 3 4 5 6 7 8 9	
08A		847238	ARANDELA VACIADO ACEITE RONDELLA WASHER	SCHEIBE RONDELLE	1 2 3 4 5 6 7 8 9	
09A		CM149801	TORNILLO C/ALLEN.6M100X55 VITE SCREW	SCHRAUBE VIS	1 2 3 4 5 6 7 8 9	
10A		847023	SEPARADOR CARTER GHIERA PIN	BUCHSE DOUILLE	1 2 3 4 5 6 7 8 9	
11A		847091	JUNTA SOPTE.VALVULA ADMISION GUARNIZIONE SOSTEGNO VALVOLA A INLET VALVE GASKET	DICHTUNG VENTILHALTER JOINT BTE.CLAPETS	1 2 3 4 5 6 7 8 9	

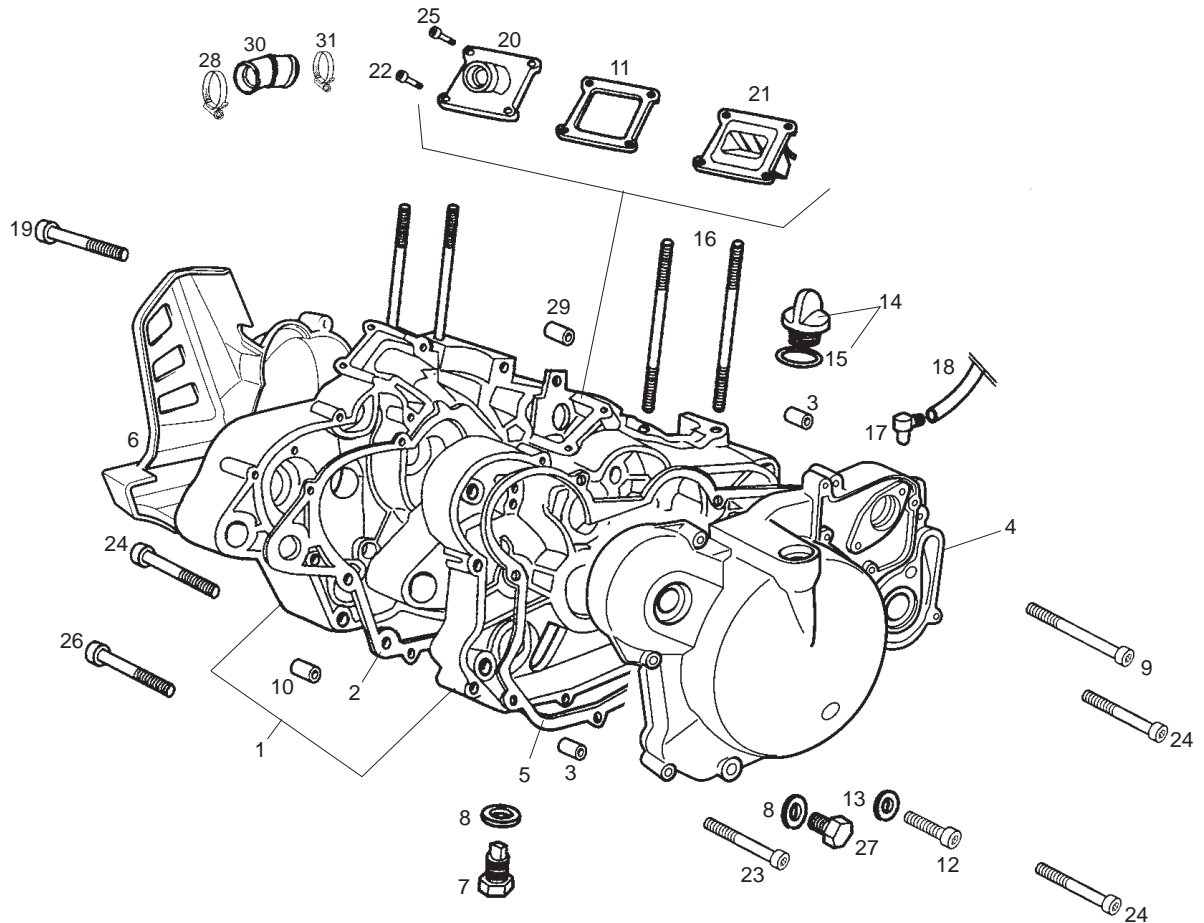

Fig.	Ver.	COD. KOD.	DESCRIPCIÓN DENOMINAZIONE NAME	BEZEICHUNG DESIGNATION	MOD.	NOTAS NOTES NOTA MITSCHRIFT NOTES
12A		847240	TORNILLO C/ALLEN.6M100X10 VITE SCREW	SCHRAUBE VIS	1 2 3 4 5 6 7 8 9	
13A		847239	ARANDELA NIVEL ACEITE.D6 RONDELLA WASHER	SCHEIBE RONDELLE	1 2 3 4 5 6 7 8 9	
14A		847087	TORNILLO LLENADO ACEITE VITE SCREW	SCHRAUBE VIS	1 2 3 4 5 6 7 8 9	
15A		847180	ANILLO TORICO TAPON NIV.ACTE. ANELLO TORICO SEAL	O-RING JOINT DE JAUGE D,HUILE	1 2 3 4 5 6 7 8 9	
16A		847015	ESPARRAGO CILINDRO MOTOR BULLONE FISSAGGIO CILINDRO STUD CYLINDER	STEBBOLZEN GOUJON DE FIXE CYLINDRE	1 2 3 4 5 6 7 8 9	
17A		847024	RACORD SALIDA GASES RACCORDI USCITA GAS CARTER . CRANKCASE VENT RACCORD	AUSGANGSSTUTZEN RACCORD DE SORTIE GAZ CARTE	1 2 3 4 5 6 7 8 9	
18A	00H03700461		TUBO RESPIRACION TUBO RESPIRAZIONE SERBATOIO VENT PIPE OIL TANK	ENTLUEFTUNGSSCHLAUCH TUYAU RESPIRATION RESERVOIR	1 2 3 4 5 6 7 8 9	
19A	00G03900821		TORNILLO FIJACION 6X30 VITE SCREW	SCHRAUBE VIS	1 2 3 4 5 6 7 8 9	
20A	847093		BOQUILLA CARBURANTE ATTACCO CARBURATORE INTAKE MANIFOLD,	ANSAUGSTUTZEN ENSEMB.PIPE DIADMISSION	1 2 3 4 5 6 7 8 9	
21A	847092		CTO.CAJA LAMINAS ADMISION CASSA LAMINA AMMISSI INLET BOX	MEMBRANE BOITE A CLAPETS	1 2 3 4 5 6 7 8 9	
22A	CM149804		TORNILLO C/ALLEN.6M100X25. VITE SCREW	SCHRAUBE VIS	1 2 3 4 5 6 7 8 9	

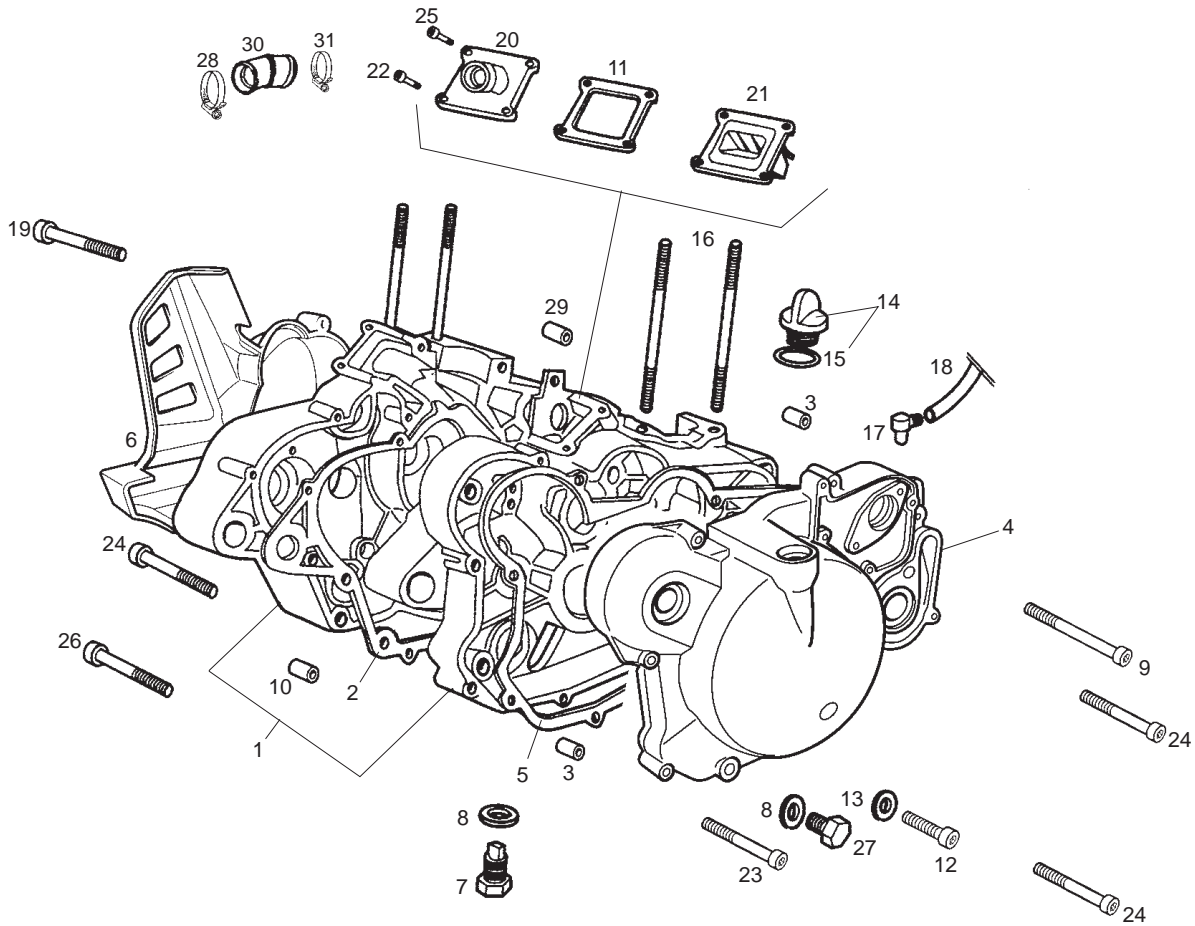

Fig.	Ver.	COD. KOD.	DESCRIPCIÓN DENOMINAZIONE NAME	BEZEICHNUNG DESIGNATION	MOD.	NOTAS NOTES NOTA MITSCHRIFT NOTES
23A		CM149806	TORNILLO C/ALLEN.6M100X35 VITE SCREW	SCHRAUBE VIS	1 2 3 4 5 6 7 8 9	
24A		CM149808	TORNILLO C/ALLEN.6M100X40 VITE SCREW	SCHRAUBE VIS	1 2 3 4 5 6 7 8 9	
25A		828152	TORNILLO VITE SCREW	SCHRAUBE VIS	1 2 3 4 5 6 7 8 9	
26A		CM149809	TORNILLO FIJACION CARTERS.6X50 VITE SCREW	SCHRAUBE VIS	1 2 3 4 5 6 7 8 9	
27A		847174	TORNILLO VACIADO ACEITE. VITE SCREW	SCHRAUBE VIS	1 2 3 4 5 6 7 8 9	
28A		00H02501491	ABRAZADERA FASCETTA CLAMP	ZÜGEL BRIDE	1 2 3 4 5 6 7 8 9	
29A		847023	SEPARADOR CARTER GHIERA PIN	BUCHSE DOUILLE	1 2 3 4 5 6 7 8 9	
30A		871319	RACORD ADMISION BRONZINA BUSHING	BUCHSE ENTRETOISE	1 2 3 4 5 6 7 8 9	
31A		847096	ABRAZADERA FASCETTA CLAMP	ZÜGEL BRIDE	1 2 3 4 5 6 7 8 9	

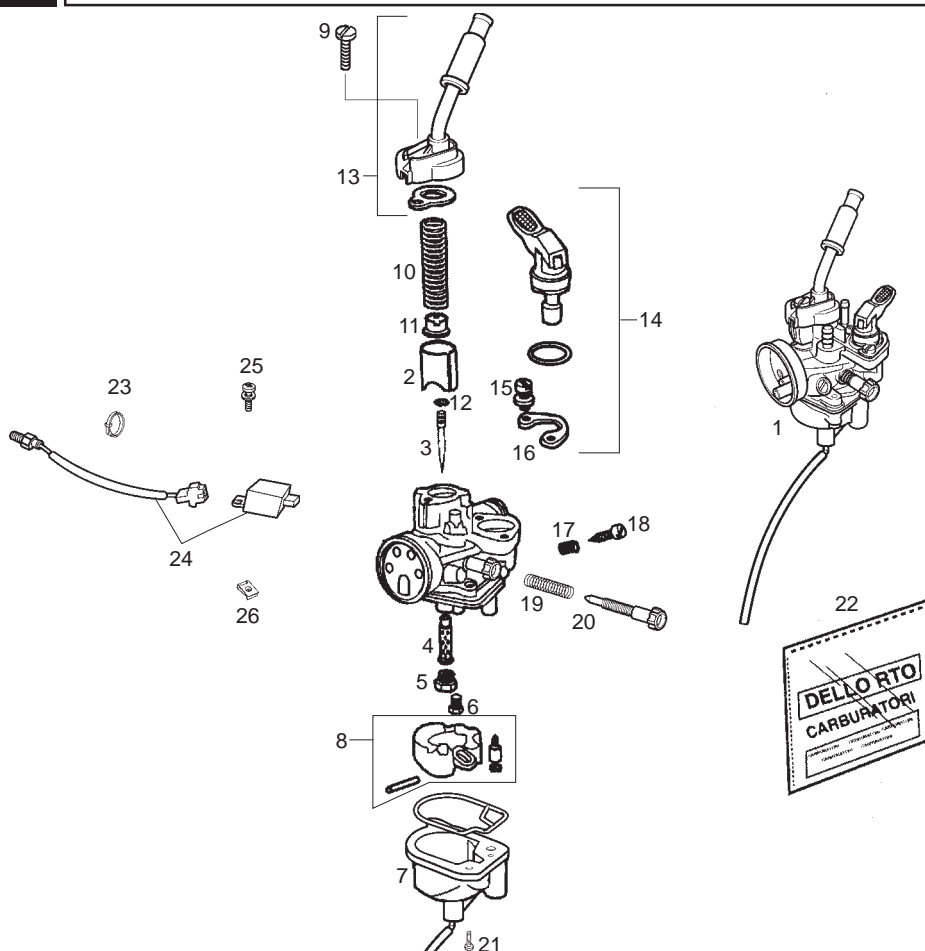

Fig.	Ver.	COD. KOD.	DESCRIPCIÓN DENOMINAZIONE NAME	BEZEICHNUNG DESIGNATION	MOD.	NOTAS NOTES NOTA MITSCHRIFT NOTES
01A		CM152702	CARBURADOR SENDA CARBURATORE CARBURETOR	VERGASER KOMPL ENSEMBLE CARBURATEUR	1 2 4 5 7 8	
01B		CM149905	CARBURADOR SENDA SCANDINAVIA CARBURATORE CARBURETOR	VERGASER KOMPL ENSEMBLE CARBURATEUR	3 6 9	
02A		00H03207211	R-COMPUERTA GAS R-VALVOLA GAS SLIDE	GASSCHIEBER BOISSEAU	1 2 4 5 7 8	
02B		00F03201211	R-COMPUERTA GAS R-VALVOLA GAS SLIDE	GASSCHIEBER BOISSEAU	3 6 9	
03A		00H03214431	R-AGUJA PULVERIZADORA SPILLO CONICO NEEDLE	DUESENDELUSE AIGUILLE PULVERIZ.	1 2 3 4 5 6 7 8 9	
04A		00H03206421	R-PULVERIZADOR «208HA» POLVERIZZATORE NEEDLE JET	ZERSTAUBERDUSE PULVERISATEUR	1 2 4 5 7 8	
04B		00H03204421	R-PULVERIZADOR «208GA» POLVERIZZATORE NEEDLE JET	ZERSTAUBERDUSE PULVERISATEUR	3 6 9	
05A		00H03208031	R-SURTIDOR MAXIMO 70 R-GETTO MASSIMO MAIN JET	HAUPT DUSE GICLEUR PRINCIPAL	1 2 4 5 7 8	
05B		00H03215031	R-SURTIDOR MAXIMO 63 R-GETTO MASSIMO MAIN JET	HAUPT DUSE GICLEUR PRINCIPAL	3 6 9	
06A		00H04101181	R-SURTIDOR MINIMO 32 R-GETTO MINIMO JET MIN	DUESE MIN. R-GICLEUR MINIMUM.	1 2 4 5 7 8	
06B		00H04106181	R-SURTIDOR MINIMO 33 R-GETTO MINIMO JET MIN	DUESE MIN. R-GICLEUR MINIMUM.	3 6 9	

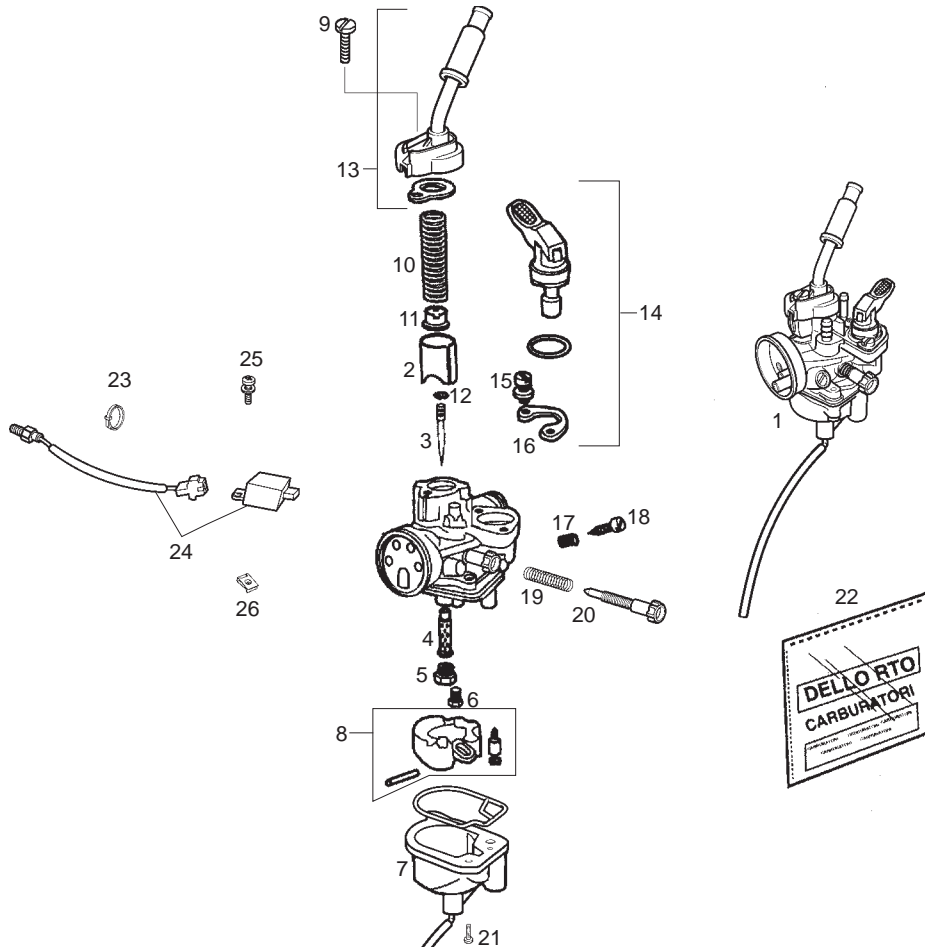

Fig.	Ver.	COD. KOD.	DESCRIPCIÓN DENOMINAZIONE NAME	BEZEICHNUNG DESIGNATION	MOD.	NOTAS NOTES NOTA MITSCHRIFT NOTES
07A		484704	VASO GASOLINA VASCHETTA BENZINA FLOAT BOWL SEET	SCHWIMMERKAMMER CUVE INFERIEURE CARBUR.	1 2 4 5 7 8	
07B		00H03201201	R-VASO GASOLINA VASCHETTA BENZINA FLOAT BOWL SEET	SCHWIMMERKAMMER CUVE INFERIEURE CARBUR.	3 6 9	
08A		00H03204281	R-KIT FLOTADOR R-GALLEGGIANTE FLOAT	SCHWIMMER R-FLOTTEUR.	1 2 4 5 7 8	
08B		00H03204281	KIT FLOTADOR R-GALLEGGIANTE FLOAT	SCHWIMMER R-FLOTTEUR.	3 6 9	
09A		00G03200061	R-TORNILLO FIJ.TAPA CAM. MEZCLA R-VITE FISSAGIO COPERCHIO CAM. MIXING XAMBER COVER SEGURING	BEF.-SCHRAUBE DECKEL MISCH R-BOUL.SER.COUV.CHAMBRE MEL	1 2 3 4 5 6 7 8 9	
10A		00G03201071	R-MUELLE VALVULA GAS R-MOLLA VALVOLA GAS THROOTLE VALVE RETURN	FEDER FUR GASVENTIL R-RESSORT VALVE ESS.	1 2 3 4 5 6 7 8 9	
11A		00G03200511	R-CASQUILLO AGUJA PULVERIZADOR GHIERA SPILLO CONICO NEEDLE BUSHING	BUCHSE DUESENNADEL R-DOUILLE AIGUI.PULVERZ.	1 2 3 4 5 6 7 8 9	
12A		00G03201371	R-PINZA AGUJA PULVERIZADOR MORSA SPILLO CONICO NEEDLE CIRCLIP	KLAMMER DUESENNADEL R-PINCE AIGUI.PULVERZ.	1 2 3 4 5 6 7 8 9	
13A		00H03204231	R-TAPA CAMARA MEZCLA R-COPERCHIO CAMARA MISCELA SE COVER CARBURETOR TOP	MISCHRAUMDECKEL COUVERCLE CARBURATEUR	1 2 3 4 5 6 7 8 9	
14A		00H03203711	R-CTO STARTER R-STARTER CHOCKE LOCK	STARTERVENTIL VANNE DU STARTER MANUEL	1 2 3 4 5 6 7 8 9	
15A		00G03200541	R-TORNILLO FIJACION STARTER R-VITE FISSAGIO STARTER AV. AUTOMA.CHOCKE SEGURING SCREE	BEF.-SCHRAUBEAUTOM STARTER R-BOULON SER.START	1 2 3 4 5 6 7 8 9	

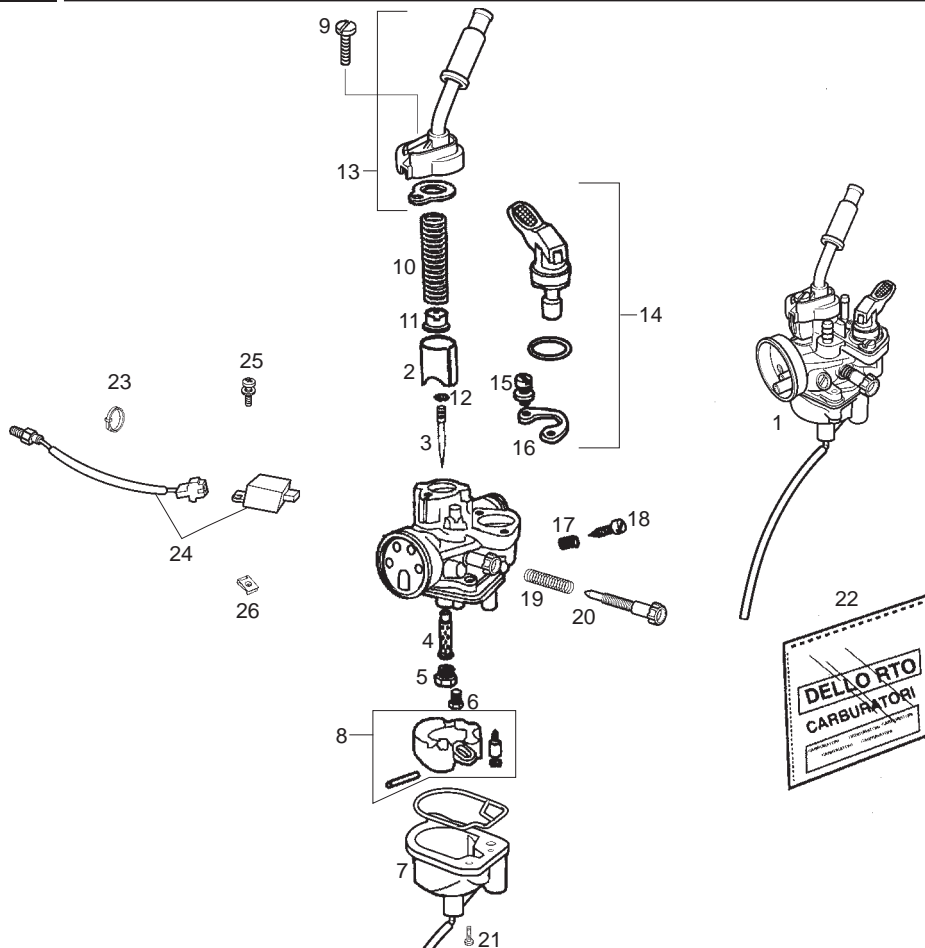

Fig.	Ver.	COD. KOD.	DESCRIPCIÓN DENOMINAZIONE NAME	BEZEICHNUNG DESIGNATION	MOD.	NOTAS NOTES NOTA MITSCHRIFT NOTES
16A		00G03200551	R-PRECINTO FIJACION STARTER PIASTRINA FIS. STARTER AUTOMA.CHOCKE SEGURING SCREE	HALTERUNG AUTOM. STARTER R-PLOMBAGE FIX.START	1 2 3 4 5 6 7 8 9	
17A		00G03200721	R-MUELLE REGULACION AIRE MIN. MOLLA REG. ARIA IDLE ADJUSTER	FEDER LUFTREGLER MIN. R-RESSORT REG.AIR MIN.	1 2 3 4 5 6 7 8 9	
18A		00G03200731	R-TORNILLO REGULACION AIRE MIN. R-VIS REG.AIR.MIN. IDLE ADJUSTER SCREW	LUFT-REGULIERSCHRAUBE MIN. R-VIS REG.AIR MIN.	1 2 3 4 5 6 7 8 9	
19A		00G03200101	R-MUELLE REGULACION VALVULA GAS MOLLA REG. VALVOLA GAS THROTTLE VALVE ADJUSTE SPRING	FEDER GAS-VENTIL-REGELUNG R-RES.REG.VALVE ESS.	1 2 3 4 5 6 7 8 9	
20A		00G04102131	R-TORNILLO REGULACION VALVULA GAS R-VITE FISSAGIO VASCHETTA THROTTLE VALVE ADJUSTER SCREW	SCHRAUBE GAS-VENTIL-REGELU R-VIS REG.VALV.ESS.	1 2 3 4 5 6 7 8 9	
21A		00G03201091	R-TORNILLO FIJACION VASO GASOLINA R-VITE FISSAGIO VASCHETTA BE FLOAT CHAMBER SEGURING SCREW	BEF.-SCHRAUBE R-BOUL.SERG.VASE ESSENC.	1 2 3 4 5 6 7 8 9	
22A		00H04103771	R-JUEGO JUNTAS CARBURADOR R-GUARNIZIONE CARBU. CARBURETOR GASKET	DICHTUNGSATZ KOMPL. VERGAS R-ENS. JOINTS CARBUR.	1 2 3 4 5 6 7 8 9	
23A		00A00900531	BRIDA FLANGIA UNIONE CAVI CLAMP	KLAMMER COLLIER	3 6 9	
24A		00H06001151	CTO KIT CALENTADOR CARBURADOR KIT RISCALDAMENTO KIT CARBURETTOR HEATER	KABELBAUN FUR HEIZUNG VERG KIT QUI CHAUFFE CARBURATEUR	3 6 9	
25A		00F05900041	SCTO TORNILLO 6M100X16 VITE SCREW	SCHRAUBE VIS	3 6 9	
26A		00D01501371	TUERCA FIJACION D6 DADO NUT	MUTTER ECROU	3 6 9	

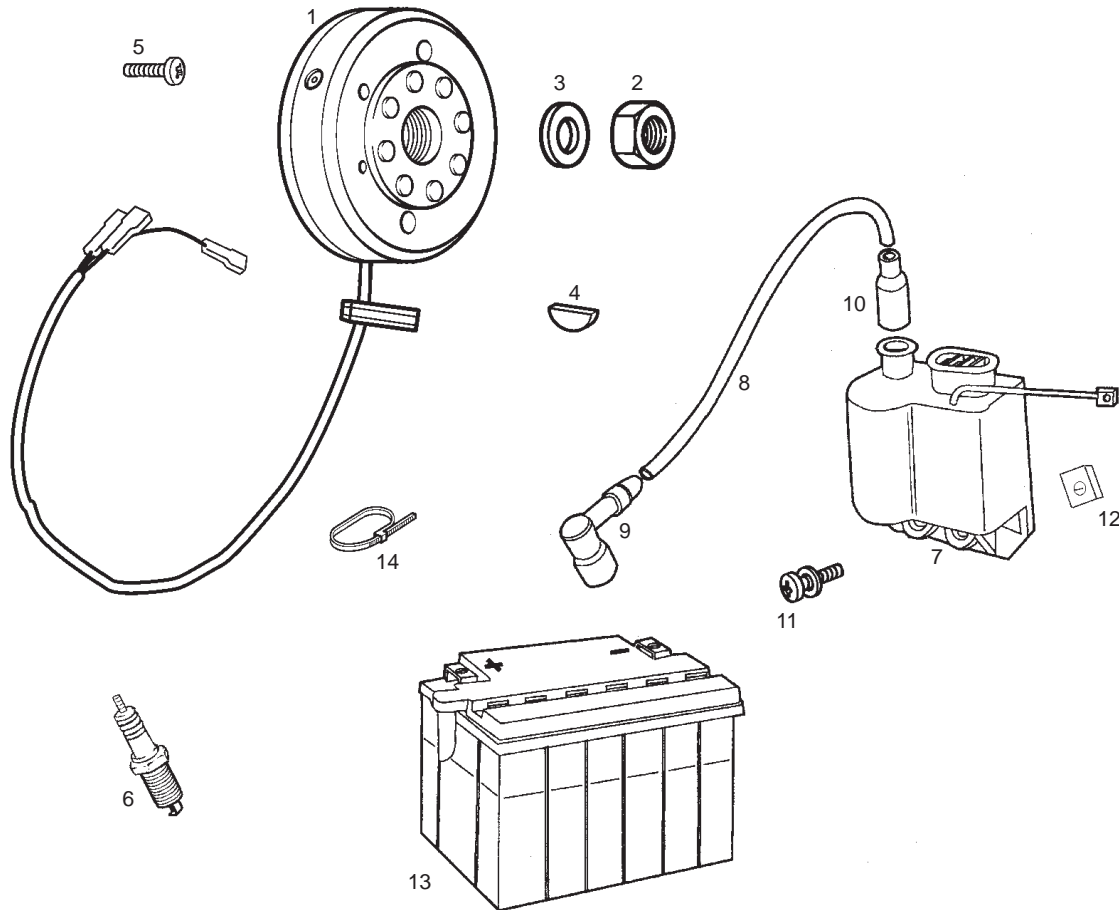

Fig.	Ver.	COD. KOD.	DESCRIPCIÓN DENOMINAZIONE NAME	BEZEICHNUNG DESIGNATION	MOD.	NOTAS NOTES NOTA MITSCHRIFT NOTES
01A		82829R	CTO VOLANTE MAGNETICO VOLANO ELETTRONICO MAGNETO ASSEMBLY	LICHTMASCHINE KOMPL. VOLANT MAGNETIQUE	1 2 3 4 5 6 7 8 9	
02A		847235	TUERCA FIJACION VOLANTE.MAGN. DADO NUT	MUTTER ECROU	1 2 3 4 5 6 7 8 9	
03A		847234	ARANDELA FIJ. VOLANTE.MAGN RONDELLA WASHER	SCHEIBE RONDELLE	1 2 3 4 5 6 7 8 9	
04A		847215	CHAVETA VOLANTE MAGNETICO SPINA VOLANO MAGNETICO .P.REC. KEY, FLYWHEEL	KEIL CLAVETTE VOLANT MAGNETIQUE	1 2 3 4 5 6 7 8 9	
05A		847233	TORNILLO FIJ.VOLTE.MAGN.5M80X10. VITE SCREW	SCHRAUBE VIS	1 2 3 4 5 6 7 8 9	
06A		847085	BUJIA CANDELA SPARK PLUG	KERZE BOUGIE	1 2 3 4 5 6 7 8 9	
07A		00H03330171	CTO CONVERSION ELECTRONICO COVERTITORE ELETTRON COIL, PRIMARY IGNITION	ZUNDSPULE BOBINE AUTE TENSION	1 2 4 5 7 8	
07B		00H03334171	CTO CONVERSION ELECTRONICO COVERTITORE ELETTRON COIL, PRIMARY IGNITION	ZUNDSPULE BOBINE AUTE TENSION	3 6 9	
08A		00F03310741	CABLE BOBINA CAVO BOBINA CABLE COIL PRIMARY IGNITION	ZUNDSPULENKABEL CABLE	1 2 3 4 5 6 7 8 9	
09A		00G03301271	CTO. PIPA BUJIA PIPETA CANDELA COVER, SPARK PLUG	ZUNDKERZENSTECRER PIPE DE BOUGIE	1 2 3 4 5 6 7 8 9	
10A		00F03300731	CAPUCHON CABLE BOBINA CAPPUCCIO CAVO BOBINA COIL CABLE RUBBER PROTECTOR	KAPPE CAPUCHON	1 2 3 4 5 6 7 8 9	

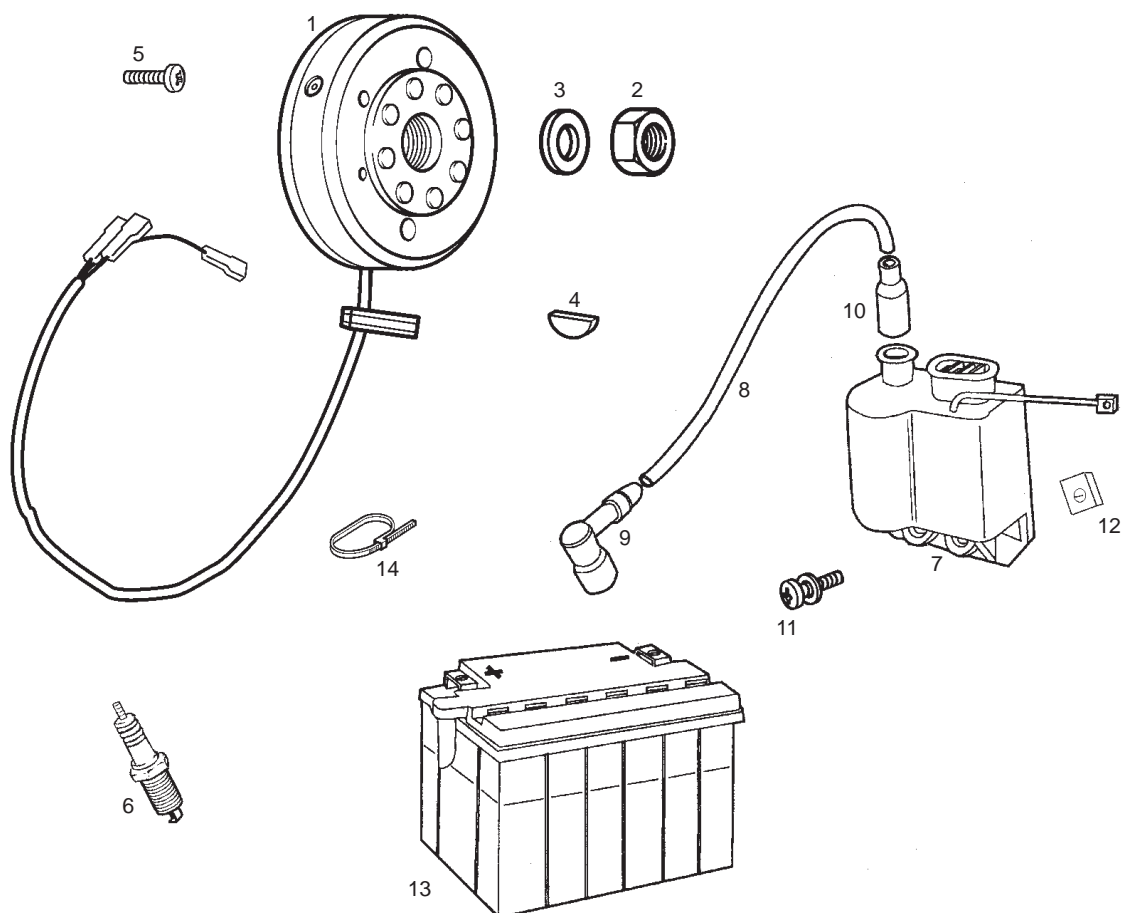

Fig.	Ver.	COD. KOD.	DESCRIPCIÓN DENOMINAZIONE NAME	BEZEICHNUNG DESIGNATION	MOD.	NOTAS NOTES NOTA MITSCHRIFT NOTES
11A		00G06800021	SCTO. TORNILLO 6M100X20 VITE SCREW	SCHRAUBE VIS	1 2 3 4 5 6 7 8 9	
12A		00D01501371	TUERCA FIJACION D6 DADO NUT	MUTTER ECROU	1 2 3 4 5 6 7 8 9	
13A		00G03301401	BATERIA 12V BATTERIA BATTERY	BATTERIE BATTERIE	1 2 3 4 5 6 7 8 9	
14A		00F00900531	BRIDA 290 X 4,8 FASCETTA FISSAGGIO RUBINETTO FUEL COCK SECURING CLAMP	BEF.-SCHELLE F.HAHN BRIDE FIXATION ROBINET	1 2 3 4 5 6 7 8 9	

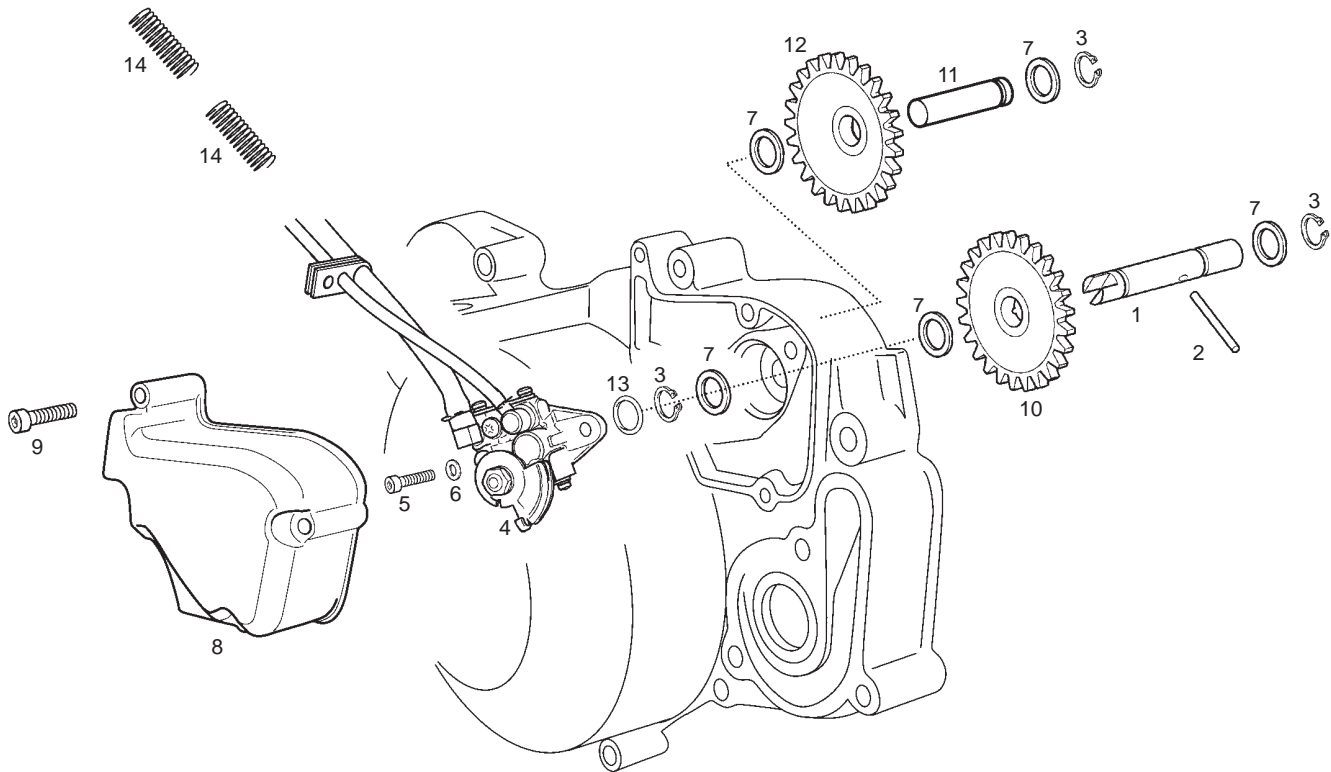

Fig.	Ver.	COD. KOD.	DESCRIPCIÓN DENOMINAZIONE NAME	BEZEICHNUNG DESIGNATION	MOD.	NOTAS NOTES NOTA MITSCHRIFT NOTES
01A		847052	EJE BOMBA ACEITE ASSE POMPA OLIO PUMPOIL AXLE	OLPUMPUNACHSE AXE DE POMPE D,HUILLE	1 2 3 4 5 6 7 8 9	
02A		847184	PASADOR EJE BOMBA CHIAVISTELLO SOSTEGNO SPIRALE FORK PIN	STIFT GOUDILLE	1 2 3 4 5 6 7 8 9	
03A		847182	ANILLO SEGURIDAD EJES D8 ANELLO SICUREZZA CIRCLIP	SEEGERRING CIRCLIP	1 2 3 4 5 6 7 8 9	
04A		847055	CTO. BOMBA ACEITE POMPA OLIO OIL PUMP	OLPUMPE POMPE A HUILLE	1 2 3 4 5 6 7 8 9	
05A		847227	TORNILLO C/ALLEN 5M80X15 VITE SCREW	SCHRAUBE VIS	1 2 3 4 5 6 7 8 9	
06A		847226	ARANDELA D5 RONDELLA WASHER	SCHEIBE RONDELLE	1 2 3 4 5 6 7 8 9	
07A		847183	ARANDELA TOPE PIÑON INTERMEDIO RONDELLA WASHER	SCHEIBE RONDELLE	1 2 3 4 5 6 7 8 9	
08A		00H03706011	TAPA BOMBA ACEITE COPERCHIO COVER	DECKEL COUVERCLE	1 2 3 4 5 6 7 8 9	
09A		00004154000	TORNILLO C/ALLEN 5M80X40 VITE SCREW	SCHRAUBE VIS	1 2 3 4 5 6 7 8 9	
10A		847051	PIÑON BOMBA ACEITE Z25 PIGNONE GEAR	ZAHNRAD PIGNON	1 2 3 4 5 6 7 8 9	
11A		847076	EJE PIÑONES INTERMEDIOS ASSE AXLE	ACHSE AXE	1 2 3 4 5 6 7 8 9	

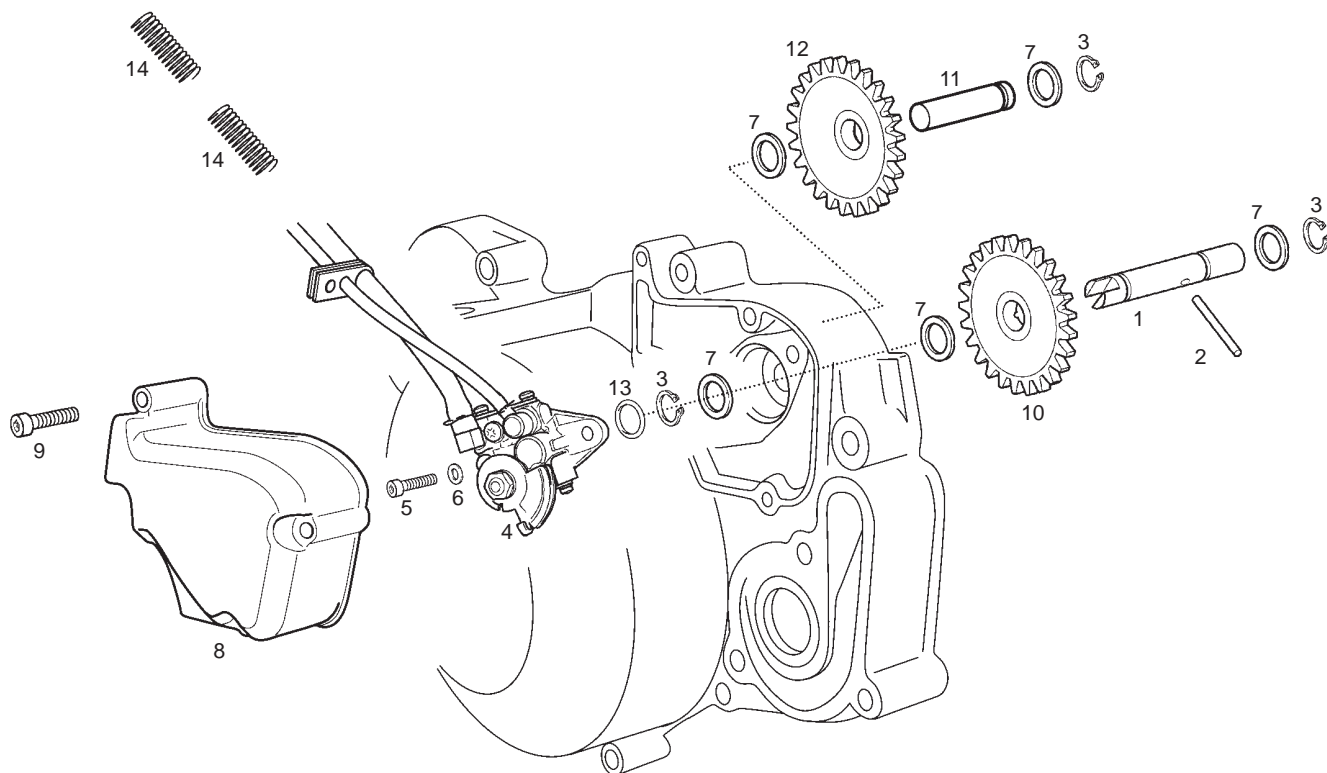

Fig.	Ver.	COD. KOD.	DESCRIPCIÓN DENOMINAZIONE NAME	BEZEICHNUNG DESIGNATION	MOD.	NOTAS NOTES NOTA MITSCHRIFT NOTES
12A		847053	PIÑÓN INTERMEDIO BOMBA Z13/24 PIGNONE GEAR	ZAHNRAD PIGNON	1 2 3 4 5 6 7 8 9	
13A		311163	JUNTA BOMBA ACEITE GUARNIZIONE GASKET	DICHTUNG JOINT	1 2 3 4 5 6 7 8 9	
14A		00H03701511	MUELLE PROTECCION TUBO ACEITE MOLLA SPRING	FEDER RESSORT	1 2 4 5 7 8	

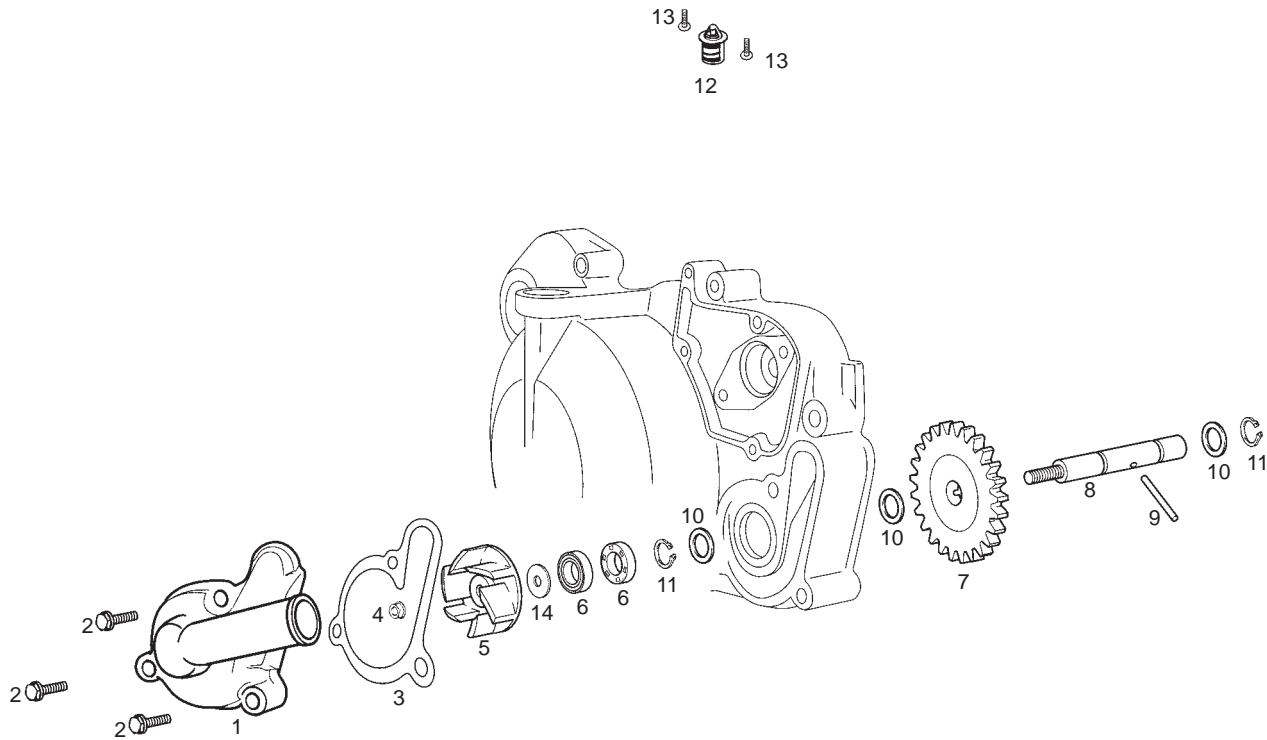

Fig.	Ver.	COD. KOD.	DESCRIPCIÓN DENOMINAZIONE NAME	BEZEICHNUNG DESIGNATION	MOD.	NOTAS NOTES NOTA MITSCHRIFT NOTES
01A		CM150802	TAPA BOMBA AGUA COPERCHIO POMPA ACQUA WATER PUMP COVER	DECKEL F. WASSERPUMPE COUVERCLE DE POMPE D,EAU	1 2 3 4 5 6 7 8 9	
02A		CM149805	TORNILLO FIJACION 6X30 Zn.B VITE SCREW	SCHRAUBE VIS	1 2 3 4 5 6 7 8 9	
03A		871688	JUNTA TAPA BOMBA AGUA GUARNIZIONE COPERCHIO GASKET	DICHTUNG F. WASSERPUMPENDE JOINT	1 2 3 4 5 6 7 8 9	
04A		847067	TUERCA 5M80 LATON DADO NUT	MUTTER ECROU	1 2 3 4 5 6 7 8 9	
05A		847079	RODETE BOMBA AGUA ROCCHETTO POMPA ACQUA WATER PUMP ROLLER	LAUFER F. WASSERPUMP CHIGNON POMPE D,EAU	1 2 3 4 5 6 7 8 9	
06A		847077	RETEN EJE BOMBA GIUNTO TENUTA SEAL	DICHTRING JOINT	1 2 3 4 5 6 7 8 9	
07A		847080	PIÑÓN BOMBA AGUA Z-32 PIGNONE GEAR	ZAHNRAD PIGNON	1 2 3 4 5 6 7 8 9	
08A		847078	EJE BOMBA AGUA ASSE POMPA ACQUA WATER-PUMP SHAFT	WASSERPUMPENACHSE AXE POMPE D,AEU	1 2 3 4 5 6 7 8 9	
09A		847184	PASADOR EJE BOMBA CHIAVISTELLO SOSTEGNO SPIRALE FORK PIN	STIFT GOUDILLE	1 2 3 4 5 6 7 8 9	
10A		847183	ARANDELA TOPE PIÑÓN INTERMEDIO RONDELLA WASHER	SCHEIBE RONDELLE	1 2 3 4 5 6 7 8 9	
11A		847182	ANILLO SEGURIDAD D8 ANELLO SICUREZZA CIRCLIP	SEEGERRING CIRCLIP	1 2 3 4 5 6 7 8 9	

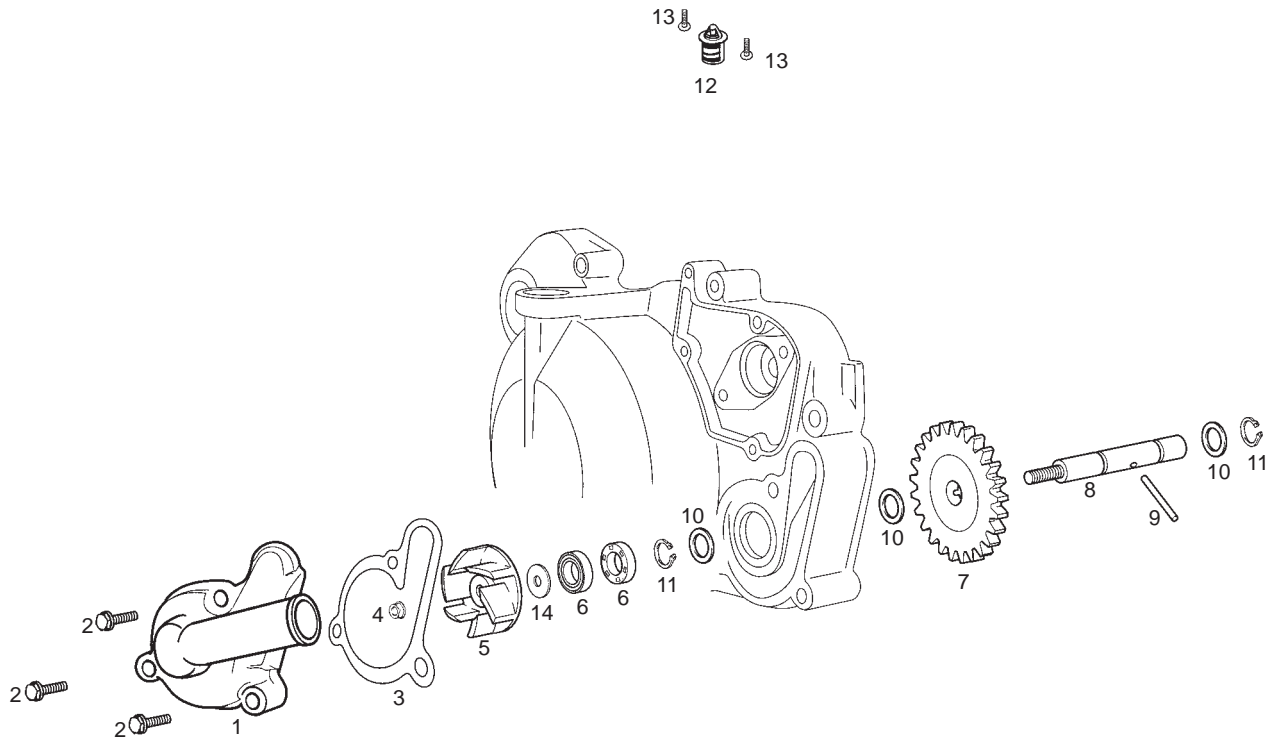

Fig.	Ver.	COD. KOD.	DESCRIPCIÓN DENOMINAZIONE NAME	BEZEICHNUNG DESIGNATION	MOD.	NOTAS NOTES NOTA MITSCHRIFT NOTES
12A		483395	INTERRUPTOR TERMICO INTERRUPTORE TERMICO THERMIC SWITCH	SCHALTER INTERRUPTEUR	1 2 3 4 5 6 7 8 9	
13A		847176	TORNILLO C/RED CRUZ NEGRO VITE SCREW	SCHRAUBE VIS	1 2 3 4 5 6 7 8 9	
14A		847181	ARANDELA RONDELLA WASHER	SCHEIBE RONDELLE	1 2 3 4 5 6 7 8 9	

Fig.	Ver.	COD. KOD.	DESCRIPCIÓN DENOMINAZIONE NAME	BEZEICHNUNG DESIGNATION	MOD.	NOTAS NOTES NOTA MITSCHRIFT NOTES
01A		00H05400451	ÚTIL MONTAJE RETENES CIGÜEÑAL CRANKSHAFT OIL SEAL FITTIN TOOL UTENSILE MONTAGGIO FERMI ALBERO A GOMITE		1 2 3 4 5 6 7 8	9
02A		00H05400581	ÚTIL MONTAJE RETÉN EJE ARRANQUE STARTER SHAFT OIL SEAL FITTIN TOOL UTENSILE MONTAGGIO FERMO ASSE AVVIAMENTO		1 2 3 4 5 6 7 8	9
03A		00H05401561	ÚTIL MONTAJE RETÉN EJE SELECTOR SELECTOR SHAFT OIL SEAL FITTIN TOOL UTENSILE MONTAGGIO FERMO ASSE SELETTORE		1 2 3 4 5 6 7 8	9
04A		00H05300041	ÚTIL FIJACIÓN CAMPANA DE EMBRAGUE CLUTHC BELL HOUSING SECURING TOOL UTENSILE FISSAGGIO CAMPANA FRIZIONE		1 2 3 4 5 6 7 8	9
05A		00H05600241	ÚTIL MONTAJE CASQUILLO DE AGUJAS EJE PRIMARIO PRIMARY SHAFT NEEDLE BUSH FITTING TOOL UTENSILE MONTAGGIO CAPUCCHIO AGHI ASSE PRIMARIO		1 2 4 5 7 8	3 6 9
06A		00H05300151	EMPUJADOR ABRIR MOTOR ENGINE OPENING PUSHER ELEMENTO DI SPINTA PER APRIRE IL MOTORE		1 2 3 4 5 6 7 8	9
07A		00H05600351	PIVOTE GUÍA RETÉN EJE SECUNDARIO GPR GPR SECONDARY SHAFT OIL SEAL GUIDE PIVOT PERNO GUIDA FERMO ASSE SECONDARIO GPR		1 2 4 5 7 8	3 6 9
08A		00F05300021	EXTRACTOR VOLANTE MAGNÉTICO ALTERNADOR ALTERNATOR MAGNETO EXTRACOR ESTRATTORE VOLANTE MAGNETICO ALTERNATORE		1 2 4 5 6 7 8	3 9
09A		00G05300011	BLOQUEADOR GIRO VOLANTE MAGNÉTICO ALTERNADOR ALTERNATOR MAGNETO TURN LOCKER BLOCANTE GIRO VOLANTE MAGNETICO ALTERNATORE		1 2 4 5 6 7 8	3 9
10A		00D05310091	PIÑÓN MOTOR SENDA SENDA ENGINE PINION PIGNONE MOTORE SENDA		1 2 3 4 5 6 7 8 9	
11A		00H05600421	RETÉN EXTERIOR BOMBA DE AGUA WATER PUMP EXTERIOR OIL SEAL FERMO ESTERNO POMPA ACQUA		1 2 3 4 5 6 7 8 9	
12A		00H05600431	RETÉN INTERIOR BOMBA DE AGUA WATER PUMP INTERIOR OIL SEAL FERMO INTERIOR POMPA ACQUA		1 2 3 4 5 6 7 8 9	
13A		00H05100101	ÚTIL TRABAR PIÑÓN MOTOR ENGINE PINION FASTENING TOOL UTENSILE PER UNIRE IL PIGNONE MOTORE		1 2 3 4 5 6 7 8	9
14A		00H05401451	JAULA EJE CONTRAPESO COUNTERWEIGHT SHAFT CAGE GABBIA ASSE CONTRAPPESO		1 2 3 4 5 6 7 8 9	
15A		00H05400461	RETÉN EJE CONTRAPESO COUNTERWEIGHT SHAFT OIL SEAL FERMO ASSE CONTRAPPESO		1 2 3 4 5 6 7 8 9	
16A		00H05601261	PIVOTE GUÍA EJE BOMBA AGUA WATER PUMP SHAFT WATER GUIDE PIVOT PERNO GUIDA ASSE POMPA ACQUA		1 2 3 4 5 7 8 9	6
17A		00H05301841	PIVOTE GUÍA RETÉN EJE CIGÜEÑAL CRANKSHAFT JOURNAL OIL SEAL GUIDE PIVOT PERNO GUIDA FERMO ASSE ALBERO A GOMITO		1 2 3 4 5 7 8	6 9

CODIGO CODE	Lám. Diagr.	Figr.	Vers.	CODIGO CODE	Lám. Diagr.	Figr.	Vers.	CODIGO CODE	Lám. Diagr.	Figr.	Vers.	CODIGO CODE	Lám. Diagr.	Figr.	Vers.
0000004510	18	24B		00012061000	03	23A		00D01500021	11	05A		00G01503701	10	06A	
00000012415	12	09A		00012061200	03	07A		00D01500471	04	32A		00G01601581	11	07A	
00000021080	06	13A		00012061200	04	20A		00D01500552	04	22A		00G01602581	11	06A	
00000023051	07	12A		00012061200	05	24A		00D01500552	13A	11A		00G01606051	11	08A	
00000023060	07	28A		00012062500	04	42A		00D01500552	13B	11A		00G02102083	06	05A	
00000023060	09	09A		00012081621	12	05A		00D01501371	03	19A		00G02200692	13A	17A	
00000031050	03	14A		00012151500	10	24A		00D01501371	04	28A		00G02200692	13B	17A	
00000031050	05	21A		00012152000	05	23A		00D01501371	05	08A		00G03200061	21	09A	
00000031050	07	45A		00012152000	11	02A		00D01501371	07	14A		00G03200101	21	19A	
00000031080	06	10A		00012161600	04	30A		00D01501371	13A	06A		00G03200511	21	11A	
00000033040	18	25A		00014041200	06	09A		00D01501371	13B	06A		00G03200541	21	15A	
00000034050	18	25B		00022083021	08	21A		00D01501371	21	26A		00G03200551	21	16A	
00000036100	19	17A		00022084021	01	04A		00D01501371	22	12A		00G03200721	21	17A	
00000056205	01	14A		00022084521	01	07A		00D01520096	01	20A		00G03200731	21	18A	
00000061040	19	18A		00023108000	01	05A		00D01540456	01	21A		00G03201071	21	10A	
00001113192	09	04A		00023108000	10	20A		00D02100901	06	22A		00G03201091	21	21A	
00002041050	18	24A		00023108000	12	07A		00D02600631	04	35A		00G03201371	21	12A	
00002062011	12	04A		00023112000	03	13A		00D02600631	10	26A		00G03204272	04	13A	
00002062511	17	09A		00026005000	07	15A		00D02600631	11	03A		00G03301271	22	09A	
00002082021	11	10A		00031086022	08	24A		00D02600631	12	12A		00G03301401	22	13A	
00002182000	09	08A		00031106000	02	22A		00D02600631	13A	23A		00G03800601	13A	04A	
00002212070	08	10A		00031106000	07	21A		00D02600631	13B	23A		00G03800601	13B	04A	
00002212070	09	21A		00031106000	07	25A		00D03210491	04	27B		00G03800741	13A	24A	
00002215152	01	25A		00034000802	08	23A		00D03700131	04	12A		00G03800741	13B	24A	
00002503230	03	04A		00036008000	01	02A		00D03700131	13A	31A		00G03801701	13A	12A	
00002518790	01	17A		00037000600	19	21A		00D05310091	25	10A		00G03801701	13B	12A	
00003112322	03	03A		00047030400	04	04A		00D05900031	13A	35A		00G03801701	13B	34A	
00003112322	08	03A		00047030900	19	16A		00D05900031	13B	39A		00G03900821	20	19A	
00003115422	03	12A		00058120100	08	04A		00D05900081	07	17A		00G04102131	21	20A	
00003127200	19	19A		00058120100	09	05A		00D05910081	12	13A		00G04400752	05	12A	
00003306570	01	28A		00073481964	04	31A		00F00400131	04	07A		00G04401462	05	04A	
00003710110	07	04A		00092061214	13A	15A		00F00400771	04	08A		00G04401462	07	38A	
00003710120	07	05A		00092061214	13B	15A		00F00403321	04	14A		00G04401462	10	25A	
00004053500	07	32A		00232120032	08	16A		00F00900531	06	21A		00G04700141	08	20A	
00004061600	06	23A		00262080022	01	08A		00F00900531	07	22A		00G04700141	10	23A	
00004154000	23	09A		00262100032	01	27A		00F00900531	10	10A		00G05300011	25	09A	
00004162500	19	20A		00262120032	03	24A		00F00900531	22	14A		00G06300671	05	07A	
00005010760	06	25A		00262120032	09	13A		00F00902291	06	06A		00G06800021	22	11A	
00005527540	10	19A		00402060001	09	03A		00F00910291	06	16A		00H00204601	02	04A	
00005551290	14	03A		00402080001	01	03A		00F00920551	06	18A		00H00300912	03	21A	
00006309260	06	26A		00402080001	08	22A		00F01210312	09	12A		00H00301401	03	05A	
00006309260	10	02A		00402080001	10	18A		00F03201211	21	02B		00H00303892	03	11A	
00006321040	06	12A		00402080001	12	06A		00F03300731	22	10A		00H00308971	03	01A	
00006321040	10	03A		00402100001	01	23A		00F03310741	22	08A		00H00400501	13A	18A	
00008061500	02	21A		00442060002	17	10A		00F03700131	15	21A		00H00400501	13A	21A	
00008061500	07	39A		00A00900531	06	28A		00F03710131	04	16A		00H00400501	13B	20A	
00008063000	07	37A		00A00900531	07	20A		00F03710131	13A	07A		00H00400501	13B	33A	
00008213182	08	06A		00A00900531	13A	25A		00F03710131	13B	07A		00H00403831	04	44A	
00008902630	01	11A		00A00900531	13B	25A		00F03710241	13A	27A		00H00404051	04	24A	
00008915020	04	21A		00A00900531	21	23A		00F03710241	13B	27A		00H00404687	04	01A	
00008915020	13A	09A		00D00200761	02	26A		00F04201361	12	10A		00H00406011	04	09A	
00008915020	13B	09A		00D00900531	07	27A		00F04700121	08	25A		00H00406521	04	43A	
0000A517011	07	23A		00D00900531	13A	05A		00F04700121	10	27A		00H00501761	05	25A	
00011021300	07	16A		00D00900531	13B	05A		00F05300021	25	08A		00H00600341	04	18A	
00011041300	03	08A		00D01000701	06	24A		00F05900041	05	10A		00H00604141	04	02A	
00011041300	10	11A		00D01100201	10	04A		00F05900041	21	25A		00H00618163	05	20A	
00011051401	05	22A		00D01200171	03	18A		00G00200112	02	25A		00H00618166	05	20B	
00011051801	04	19A		00D01200171	04	29A		00G00400181	04	11A		00H00622013	04	17A	
00011141300	03	20A		00D01200171	05	14A		00G00400501	04	10A		00H00705121	05	13A	
00011141300	13A	22A		00D01201091	08	11A		00G00400501	13A	30A		00H00712023	05	01B	
00011141300	13B	22A		00D01300091	08	05A		00G00400501	13B	30A		00H00712024	05	01A	
00012045000	07	40B		00D01300192	03	06A		00G01001571	07	13A		00H00712341	05	11A	
00012051200	07	44A		00D01301401	09	10A		00G01500951	12	03A		00H00800422	01	13A	
00012053000	07	40A		00D01500021	05	19A		00G01503701	05	09A		00H00804081	01	10A	

CODIGO CODE	Lám. Diagn.	Figr.	Vers.	CODIGO CODE	Lám. Diagn.	Figr.	Vers.	CODIGO CODE	Lám. Diagn.	Figr.	Vers.	CODIGO CODE	Lám. Diagn.	Figr.	Vers.
00H00805072	01	12A		00H01600911	11	04A		00H03703051	13B	28A		00H05600431	25	12A	
00H00819012	01	09A		00H01616021	11	09A		00H03704081	13A	26A		00H05601261	25	16A	
00H00912012	06	01A		00H01625521	11	01A		00H03704081	13B	26A		00H05700101	07	42B	
00H00915751	06	11A		00H01628521	11	01B		00H03706011	23	08A		00H05700481	07	35A	
00H00917301	06	17A		00H01703301	07	24A		00H03800571	04	45A		00H05701061	07	46A	
00H00930071	06	15A		00H01703391	07	26A		00H03800722	07	11A		00H05701101	07	42A	
00H00930091	06	04A		00H01800402	12	08A		00H03800751	13A	14A		00H05703141	07	06A	
00H00931171	06	03A		00H01801411	11	11A		00H03800751	13A	33A		00H05900021	03	17A	
00H00934171	06	03B		00H01801771	01	15A		00H03800751	13B	14A		00H05900021	04	34A	
00H01000131	07	07A		00H01802081	02	18A		00H03800751	13B	18A		00H05900021	05	02A	
00H01000371	07	10A		00H01803331	03	09A		00H03800751	13B	31A		00H05900021	05	03A	
00H01001701	10	07A		00H01809541	04	25A		00H03801961	13A	20A		00H05900021	05	17A	
00H01001911	07	29A		00H01961602	01	01A		00H03801961	13B	21A		00H05900021	13A	10A	
00H01002341	07	08A		00H02100191	06	07A		00H03802031	13A	16A		00H05900021	13B	10A	
00H01002821	07	33A		00H02100861	06	08A		00H03802031	13B	16B		00H05900621	05	27A	
00H01005311	07	19A		00H02101621	06	02A		00H03802091	13A	34A		00H05908251	11	12A	
00H01006321	07	09A		00H02105611	06	27A		00H03802091	13B	32A		00H06001151	21	24A	
00H01008841	07	18A		00H02201302	01	24A		00H03802461	04	37A		00H06007211	04	25B	
00H01013011	07	03B		00H02201312	01	06A		00H03802472	13A	03A		00H06101231	04	23A	
00H01015011	07	03A		00H02201591	05	18A		00H03802472	13B	03A		00H06201061	04	15A	
00H01046301	07	01A		00H02213671	06	19A		00H03802501	13A	02B		00H06300791	11	13A	
00H01100172	10	17A		00H02300961	07	30A		00H03802501	13B	02B		00H06301401	01	16A	
00H01101211	10	08A		00H02304501	07	41B		00H03802541	13A	01B		00H06303752	04	05A	
00H01101731	10	05A		00H02305381	06	14A		00H03802541	13B	01B		00H06303762	04	03A	
00H01102072	10	15A		00H02305501	07	41A		00H03802751	13A	08A		00H06500451	01	19A	
00H01103611	10	14A		00H02401282	09	18A		00H03802751	13B	08A		00H06500461	04	41A	
00H01104583	10	21A		00H02402282	08	18A		00H03804971	13A	32A		00H06800461	07	34A	
00H01106181	10	12A		00H02404331	09	01A		00H03805011	13A	01A		311163	23	13A	
00H01109081	10	01A		00H02500272	01	18A		00H03805011	13B	01A		436947	15	14A	
00H01120021	10	16A		00H02501491	20	28A		00H03805301	13A	19A		483395	24	12A	
00H01202193	08	19A		00H02703421	17	02A		00H03805301	13B	19A		484704	21	07A	
00H01202331	08	15A		00H02800421	18	23A		00H03808021	13A	13A		828152	20	25A	
00H01203272	08	02A		00H02808371	18	22B		00H03808021	13B	13A		82829R	22	01A	
00H01205711	08	08A		00H02810421	18	23B		00H03810501	13A	02A		82835R	16	10A	
00H01206061	08	09A		00H02813371	18	22A		00H03810501	13B	02A		847006	15	03A	
00H01206101	08	13A		00H02902252	19	15A		00H04101181	21	06A		847007	15	18A	
00H01208111	08	14A		00H03000272	01	26A		00H04103771	21	22A		847008	15	15A	
00H01209021	08	07A		00H03007241	20	06A		00H04106181	21	06B		847009	15	07A	
00H01212081	08	12A		00H03201201	21	07B		00H04200721	04	38A		847010	15	10A	
00H01301501	09	19A		00H03201251	04	26B		00H04200741	04	40A		847012	15	04A	
00H01301691	09	20A		00H03203711	21	14A		00H04202721	04	39A		847014	15	08A	
00H01301831	08	17A		00H03204231	21	13A		00H04302181	04	06A		847015	20	16A	
00H01301831	10	22A		00H03204281	21	08A		00H04607841	07	31A		847019	18	19A	
00H01302172	09	11A		00H03204281	21	08B		00H04607841	07	36A		847020	15	11A	
00H01302351	09	17A		00H03204421	21	04B		00H04608841	07	31B		847020	15	13A	
00H01304091	09	06A		00H03206421	21	04A		00H04608921	06	20A		847021	18	04A	
00H01304202	03	02A		00H03207211	21	02A		00H04713082	08	01A		847022	20	02A	
00H01304202	09	02A		00H03207261	04	33A		00H04903292	01	22A		847023	20	10A	
00H01305531	09	16A		00H03208031	21	05A		00H05001411	15	20A		847023	20	29A	
00H01307821	09	14A		00H03208491	04	27A		00H05100101	25	13A		847024	20	17A	
00H01308361	09	22A		00H03209251	04	26A		00H05101011	14	04A		847026	15	09A	
00H01309321	09	23A		00H03214431	21	03A		00H05101561	14	02A		847027	18	01A	
00H01317032	09	15A		00H03215031	21	05B		00H05160121	14	01A		847028	18	06A	
00H01326031	09	15B		00H03330171	22	07A		00H05300041	25	04A		847029	18	36A	
00H01500691	04	36A		00H03334171	22	07B		00H05300151	25	06A		847030	18	27A	
00H01501212	09	24A		00H03404321	12	11A		00H05301841	25	17A		847031	18	37A	
00H01501811	03	15A		00H03429412	12	02A		00H05400451	25	01A		847032	18	26A	
00H01501811	10	13A		00H03446081	12	01B		00H05400461	25	15A		847036	18	32A	
00H01502201	09	07A		00H03700131	10	09A		00H05400581	25	02A		847038	18	29A	
00H01502741	07	43A		00H03700461	20	18A		00H05401451	25	14A		847040	16	11A	
00H01502871	03	22A		00H03701411	13A	29A		00H05401561	25	03A		847042	16	12A	
00H01506201	09	07B		00H03701411	13B	29A		00H05600241	25	05A		847043	16	07A	
00H01508181	03	16A		00H03701511	23	14A		00H05600351	25	07A		847044	16	08A	
00H01508191	03	10A		00H03703051	13A	28A		00H05600421	25	11A		847045	16	03A	

CODIGO CODE	Lám. Diagr.	Figr.	Vers.	CODIGO CODE	Lám. Diagr.	Figr.	Vers.	CODIGO CODE	Lám. Diagr.	Figr.	Vers.	CODIGO CODE	Lám. Diagr.	Figr.	Vers.
847046	16	13A		847215	15	16A		863156	02	16A					
847047	16	14A		847215	22	04A		863157	02	17A					
847048	16	16A		847217	16	02A		863158	02	19A					
847051	23	10A		847218	16	04A		863159	02	20A					
847052	23	01A		847220	16	05A		863160	02	23A					
847053	23	12A		847221	16	06A		863161	02	24A					
847055	23	04A		847223	16	21A		863162	02	27A					
847056	19	08A		847224	16	15A		863163	02	28A					
847057	19	10A		847225	16	17A		863164	02	29A					
847058	19	11A		847226	23	06A		8635710002	04	17B					
847059	19	12A		847227	23	05A		8635710003	04	17C					
847060	19	07A		847228	17	08A		86357200WA5	05	05A					
847061	19	06A		847228	19	01A		86357200WB0	05	05C					
847062	19	09A		847229	19	03A		86357200WN0	05	05B					
847067	24	04A		847230	19	13A		86357300WA5	05	06A					
847068	17	06A		847231	19	14A		86357300WB0	05	06C					
847069	17	04A		847232	19	05A		86357300WN0	05	06B					
847070	17	05A		847233	22	05A		86357600WB0	05	15A					
847073	17	03A		847234	22	03A		86357700WB0	05	16A					
847074	19	04A		847235	22	02A		86357800WB0	05	15B					
847075	16	19A		847236	17	01A		86357900WB0	05	16B					
847075	17	07A		847237	20	07A		86358000WB0	07	02A					
847076	23	11A		847238	20	08A		86358100WB0	07	02C					
847077	24	06A		847239	20	13A		86358100WN0	07	02E					
847078	24	08A		847240	20	12A		86358200WB0	07	02B					
847079	24	05A		847241	20	03A		86358300WB0	07	02D					
847080	24	07A		8472625001	15	02A		86358400WA5	05	26A					
847081	18	31A		8472625002	15	02B		86358400WB0	05	26E					
847083	16	18A		8472625003	15	02C		86358400WN0	05	26C					
847084	20	05A		8472625004	15	02D		86358500WA5	05	26B					
847085	22	06A		847508	15	01A		86358500WB0	05	26F					
847086	18	03A		847529	15	17A		86358500WN0	05	26D					
847087	20	14A		847541	18	16A		86389900WN0	07	02F					
847090	16	22A		847542	18	14A		86390000WB0	05	15C					
847091	20	11A		847544	18	02A		86390100WB0	05	16C					
847092	20	21A		847545	18	18A		864489	04	06B					
847093	20	20A		847546	18	17A		864490	13A	28B					
847096	20	31A		847547	18	34A		864490	13B	28B					
847098	16	01A		847548	18	15A		864515	11	01C					
847153	18	07A		847549	18	11A		871319	20	30A					
847154	18	21A		847550	18	13A		871688	24	03A					
847155	18	09A		861001	02	13A		CM149801	20	09A					
847156	18	10A		861781	14	01B		CM149802	19	02A					
847157	18	08A		861781	14	01C		CM149804	15	19A					
847158	18	30A		862493	13B	16A		CM149804	20	22A					
847159	18	35A		862541	13B	38A		CM149805	24	02A					
847172	15	12A		862542	13B	35A		CM149806	20	23A					
847174	20	27A		862543	13B	37A		CM149808	20	24A					
847176	24	13A		862544	13B	36A		CM149809	20	26A					
847178	15	05A		862964	12	01A		CM149905	21	01B					
847179	16	09A		863136	18	29B		CM1503015	20	01A					
847180	20	15A		863143	02	01A		CM150703	20	04A					
847181	24	14A		863144	02	02A		CM150802	24	01A					
847182	23	03A		863145	02	03A		CM151201	16	20A					
847182	24	11A		863146	02	05A		CM151902	15	06A					
847183	23	07A		863147	02	06A		CM152702	21	01A					
847183	24	10A		863148	02	07A									
847184	23	02A		863149	02	08A									
847184	24	09A		863150	02	09A									
847209	18	20A		863151	02	10A									
847210	18	05A		863152	02	11A									
847211	18	12A		863153	02	12A									
847213	18	33A		863154	02	14A									
847214	18	28A		863155	02	15A									