

# NACIONAL MOTOR, S.A.U. DERBI

C/ Barcelona, nº19 - Martorelles 08107 - BARCELONA (SPAIN)  
Tel. 93 565 78 78 - Fax 93 565 78 52

---

The logo consists of the word "DERBI" in a bold, white, sans-serif font, centered within a red rectangular background. This red rectangle is flanked by two grey rectangular sections on either side, all set against a white background.

**DERBI**



---

## SENDA R DRD RACING 2004 - 2005 E2

---

CÓDIGO CATÁLOGO  
CATALOGUE NUMBER

7077CH05009



**IDENTIFICACION DE MODELOS REPRESENTADOS EN ESTE  
CATALOGO SEGUN LOS DIGITOS SIGUIENTES**

**IDENTIFICAZIONE DEI MODELLI RAPPRESENTATI IN QUESTO CATALOGO  
SECONDO I NUMERI A SEGUIRE**

**THE MODELS REFERRED INTO THIS CATALOGUE ARE IDENTIFIED  
BY FOLLOWING NUMBERS**

**BESTIMMUNG DER VERSCHIEDENEN MODELLE IN DIESEM KATALOG**

**IDENTIFICATION DES MODELOES REPRESENTES DANS CE CATALOGUE,  
EN FONCTION DES CODES SUIVANTS**

MODELO MODELLI MODEL MODELL MODELE	DENOMINACION DENOMINAZIONE MODEL NAME BEZEICHNUNG DENOMINATION	CODIGO MODELO CODICE MODELLI CODE MODEL KODE MODELL CODE MODELE
1	SENDA R DRD RACING 2004 E2 ESPAÑA AZUL ( <b>SALVIA</b> ) SENDA R DRD RACING 2004 E2 FRANCE BLUE ( <b>SALVIA</b> ) SENDA R DRD RACING 2004 E2 ENGLAND BLUE ( <b>SALVIA</b> ) SENDA R DRD RACING 2004 E2 ITALY BLUE ( <b>SALVIA</b> )	00H00033E441 00H00033F441 00H00033G441 00H00033I441
2	SENDA R DRD RACING 2004 E2 AUSTRIA BLUE ( <b>SALVIA</b> ) SENDA R DRD RACING 2004 E2 BENELUX BLUE ( <b>SALVIA</b> )	00H00033U441 00H00033X441
3	SENDA R DRD RACING 2005 E2 ESPAÑA ROJO ( <b>FLUOR</b> ) SENDA R DRD RACING 2005 E2 FRANCE RED ( <b>FLUOR</b> ) SENDA R DRD RACING 2005 E2 ENGLAND RED ( <b>FLUOR</b> ) SENDA R DRD RACING 2005 E2 ITALY RED ( <b>FLUOR</b> )	00H00033E435 00H00033F435 00H00033G435 00H00033I435
4	SENDA R DRD RACING 2005 E2 AUSTRIA RED ( <b>FLUOR</b> ) SENDA R DRD RACING 2005 E2 BENELUX RED ( <b>FLUOR</b> )	00H00033U435 00H00033X435

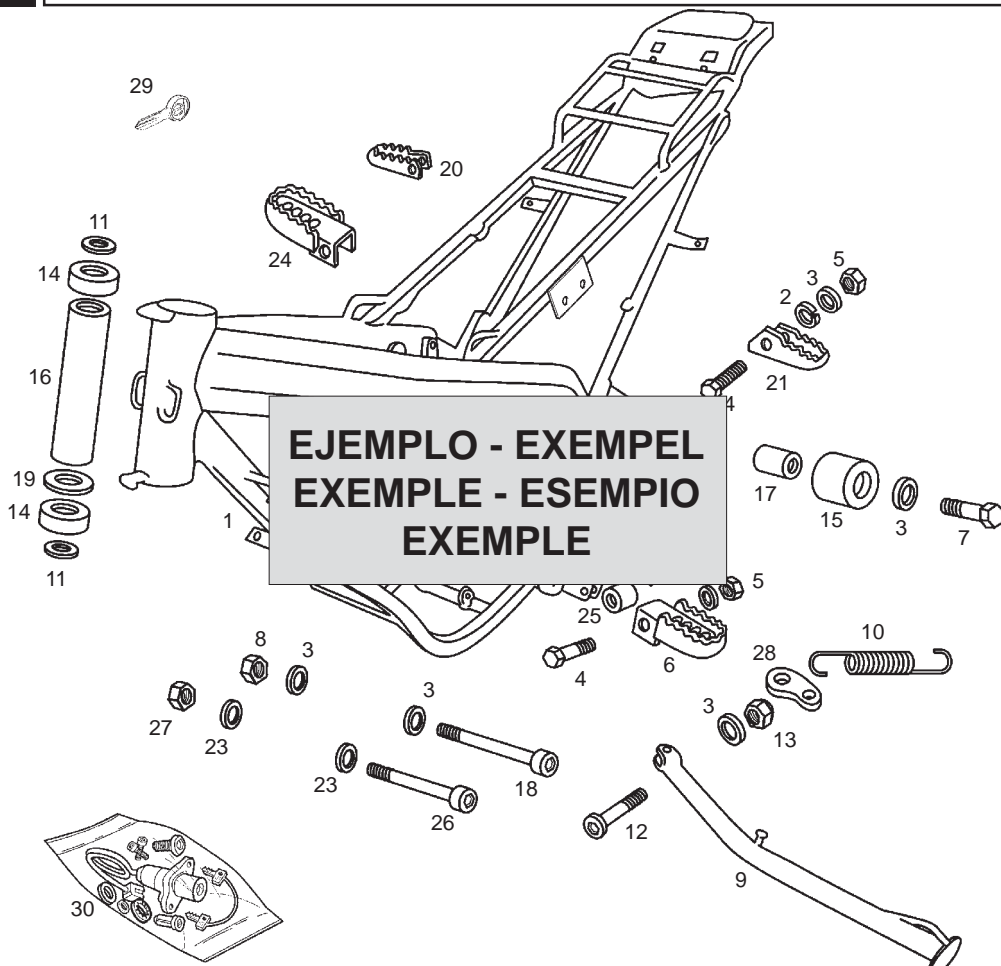

Fig.	Ver.	COD. KOD.	DESCRIPCIÓN DENOMINAZIONE NAME	BEZEICHNUNG DESIGNATION	MOD.	NOTAS NOTES NOTA MITSCHRIFT NOTES
01A		00G01924601	R-SCTO.CUADRO C/COJIN. ATLANTIS TELAIO FRAME SUB-ASSEMBLY	RHAMEN CADRE COMPLET	12	XXXXXXX
②	01A 01	00G01924601	R-SCTO.CUADRO C/COJIN. ATLANTIS TELAIO FRAME SUB-ASSEMBLY	RHAMEN CADRE COMPLET	12	XXXXXXX
③	01A 02	00G01924601	R-SCTO.CUADRO C/COJIN. ATLANTIS TELAIO FRAME SUB-ASSEMBLY	RHAMEN CADRE COMPLET	12	XXXXXXX
④	01A 03	00G01924601	R-SCTO.CUADRO C/COJIN. ATLANTIS TELAIO FRAME SUB-ASSEMBLY	RHAMEN CADRE COMPLET	12	XXXXXXX
①		⑤		⑧	⑥	⑦

1- Código de localización de piezas. 2- Código indicativo de pieza reemplazada. 3- Código indicativo de pieza anulada. 4- Código indicativo de pieza restituida (esta se monta de nuevo). 5- Código de referencia de la pieza. 6- Identificación de modelos. 7- Los códigos de esta casilla indican que, a partir del número de chasis o motor indicado dentro de esta, se monta una nueva pieza que reemplaza a la anterior (sección 2), que una pieza no se monta (sección 3), o que la pieza anulada se monta de nuevo (sección 4), y concierne a los modelos indicados (sección 6). 8- Denominación de la pieza.

1- Codice di localizzazione pezzi. 2- Codice indicatore del pezzo sostituito. 3- Il pezzo precedente non si monta. 4- Codice indicatore dei pezzi che si tornano a montare. 5- Codice di identificazione del pezzo. 6- Identificazione del modello. 7- Il codice di questa casella indica che, dal numero di Telaio/motore indicato, si monta un nuovo pezzo che sostituisce il precedente (sezione 2), che un pezzo non si monta (sezione 3), oppure che il pezzo annullato si monta di nuovo (sezione 4), facendo riferimento al modello indicato (sezione 6). 8- Denominazione del pezzo.

1- Part location number. 2- Substituted part number. 3- Withdrawn part number (no longer fitted). 4- Restored part number (newly fitted going withdrawn). 5- Part reference number. 6- Model identification number. 7- Chassis or engine number from which a new part is fitted substituting a part which has been withdrawn (see para 2) or a part is withdrawn is fitted again (see para 4), in the models indicated (see para 6). 8- Part identification label.

1- Zeichnung - Nummer. 2- Ausführung. 3- Gestrichene Ersatzteilnummer. 4- Ersetzte Ersatzteilnummer. 5- Ersatzteilnummer. 6- Modell - Nummer. 7- Rhamen - order motonummer, für die ein neues teil eingestzt wird, z.b. eine nummer, die geändert (s. para 2), order ein teil, das gestrichen wurde (s. para 3), order ein teil, das vorübergehend verschiedene modelle (s. para 6) 8- Bezeichnung.

1- Code de localisation de la pièce. 2- Code indicateur de pièce remplacé par un autre. 3- Code indicateur de pièce annulé (elle n'est plus montée). 4- Code indicateur de pièce restituée (elle se monte à nouveau). 5- Code référence de la pièce. 6- Les codes de cette case indiquant qu'à partir de numero 7- Chassis ou de moteur indiqué, un nouvelle pièce est montée en remplacement d'une autre (section 2), qu'une pièce n'est plus montée (section 3) ou la pièce anulée est montée à nouveau (section 4) et concernant les modèles indiqués (section 6). 8- Denomination de la pièce.

LAMINA / STAMPA / DIAGRAM / BILD / FEUILLE - 1

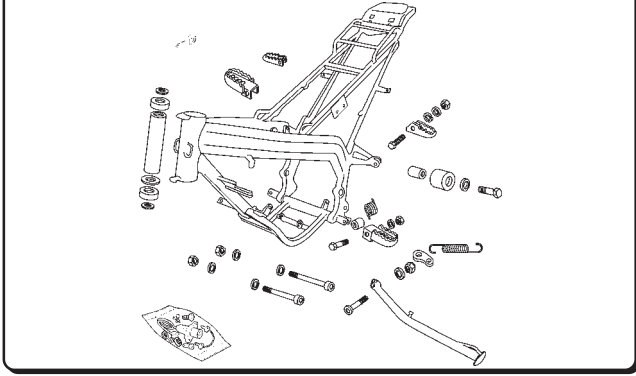

LAMINA / STAMPA / DIAGRAM / BILD / FEUILLE - 2

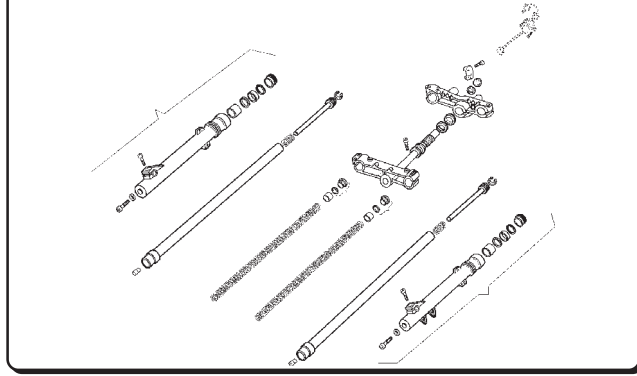

LAMINA / STAMPA / DIAGRAM / BILD / FEUILLE - 3

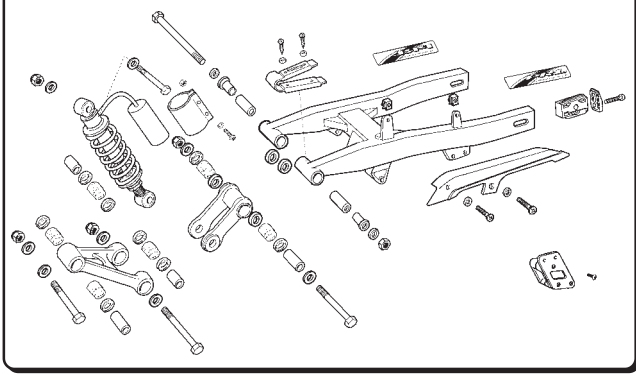

LAMINA / STAMPA / DIAGRAM / BILD / FEUILLE - 4

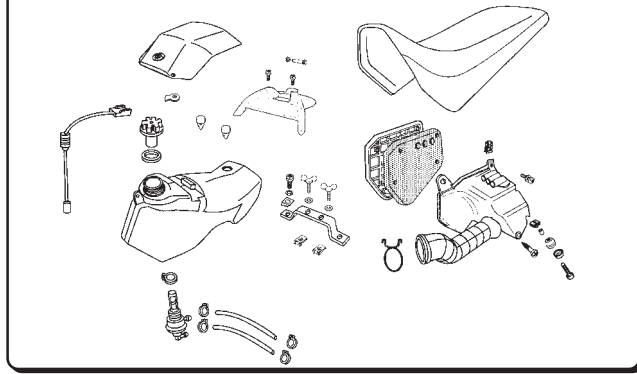

LAMINA / STAMPA / DIAGRAM / BILD / FEUILLE - 5

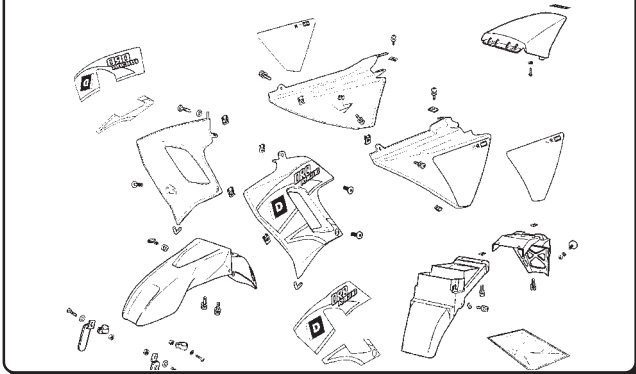

LAMINA / STAMPA / DIAGRAM / BILD / FEUILLE - 6

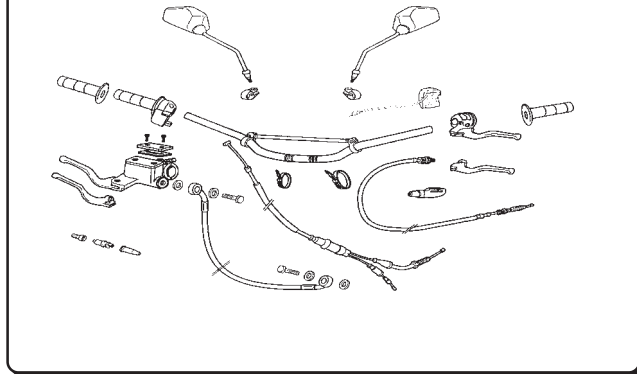

LAMINA / STAMPA / DIAGRAM / BILD / FEUILLE - 7

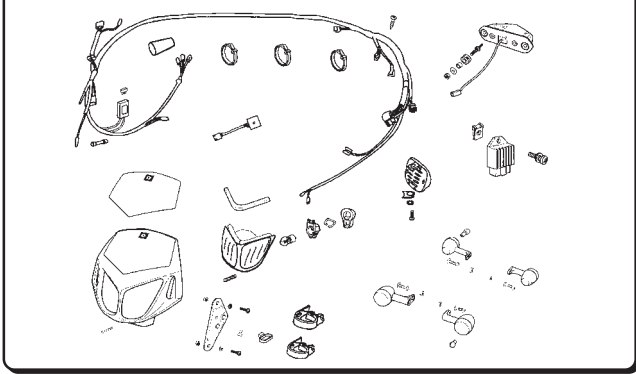

LAMINA / STAMPA / DIAGRAM / BILD / FEUILLE - 8

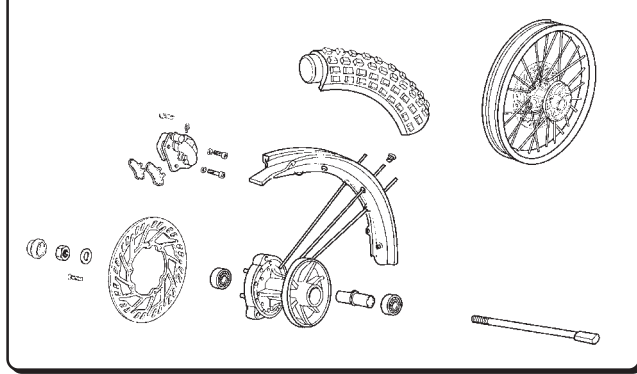

LAMINA / STAMPA / DIAGRAM / BILD / FEUILLE - 9

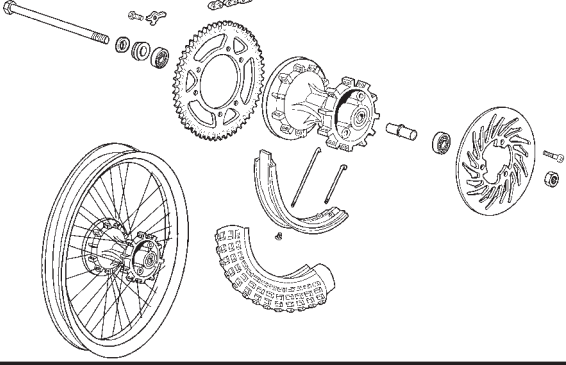

LAMINA / STAMPA / DIAGRAM / BILD / FEUILLE - 10

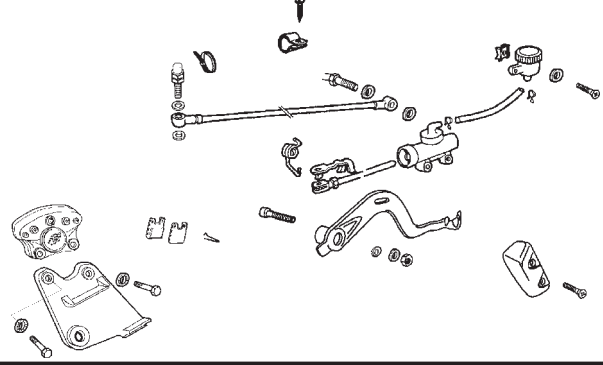

LAMINA / STAMPA / DIAGRAM / BILD / FEUILLE - 11

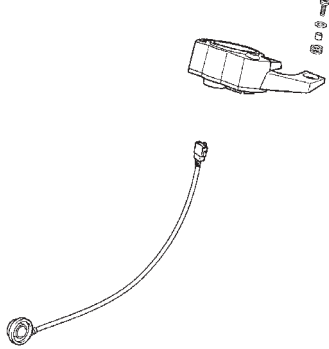

LAMINA / STAMPA / DIAGRAM / BILD / FEUILLE - 12

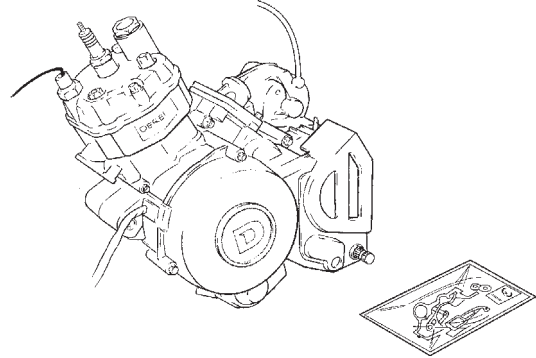

LAMINA / STAMPA / DIAGRAM / BILD / FEUILLE - 13

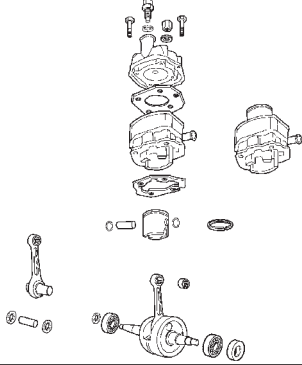

LAMINA / STAMPA / DIAGRAM / BILD / FEUILLE - 14

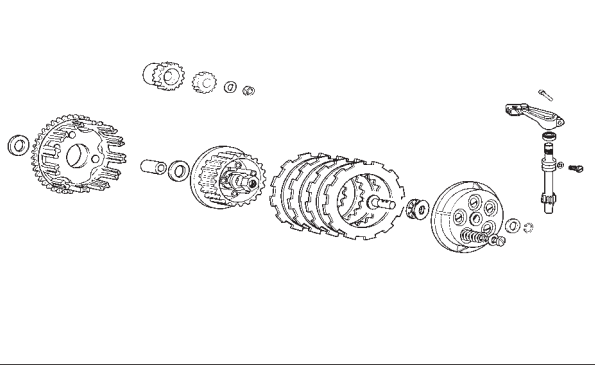

LAMINA / STAMPA / DIAGRAM / BILD / FEUILLE - 15

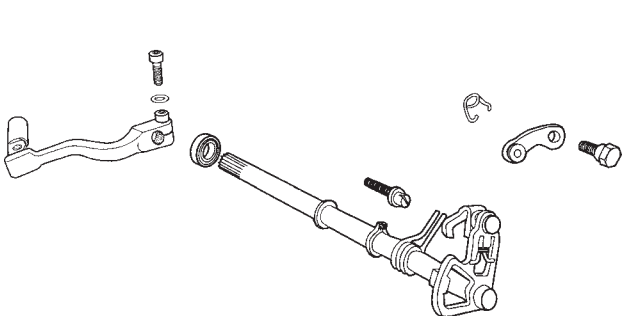

LAMINA / STAMPA / DIAGRAM / BILD / FEUILLE - 16

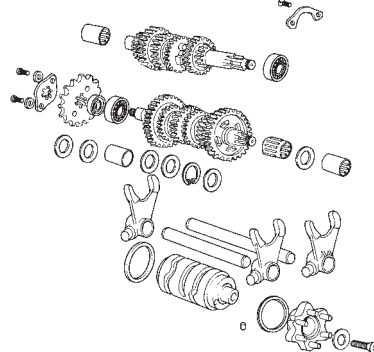

LAMINA / STAMPA / DIAGRAM / BILD / FEUILLE - 17

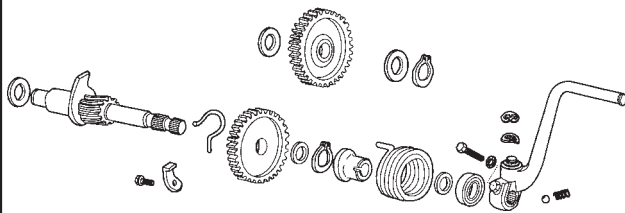

LAMINA / STAMPA / DIAGRAM / BILD / FEUILLE - 18

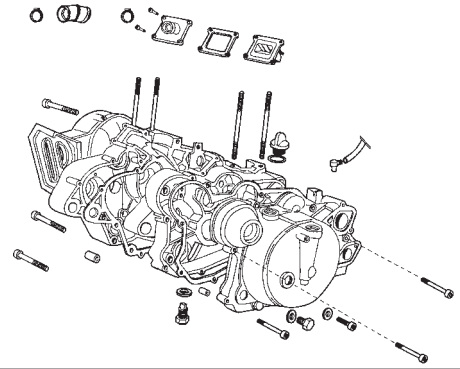

LAMINA / STAMPA / DIAGRAM / BILD / FEUILLE - 19

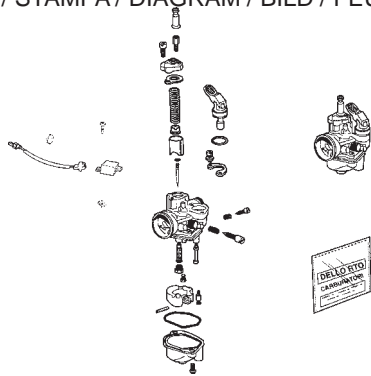

LAMINA / STAMPA / DIAGRAM / BILD / FEUILLE - 20

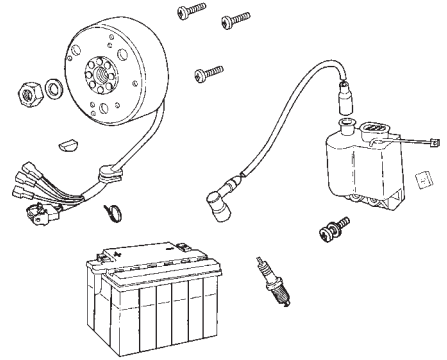

LAMINA / STAMPA / DIAGRAM / BILD / FEUILLE - 21

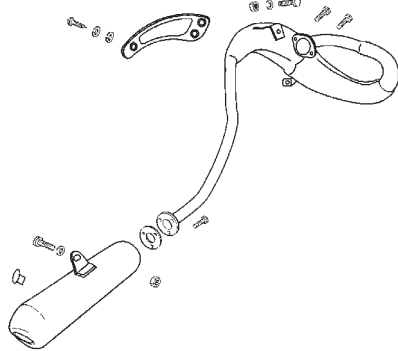

LAMINA / STAMPA / DIAGRAM / BILD / FEUILLE - 22

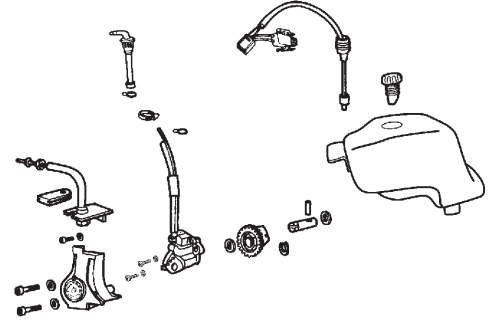

LAMINA / STAMPA / DIAGRAM / BILD / FEUILLE - 23

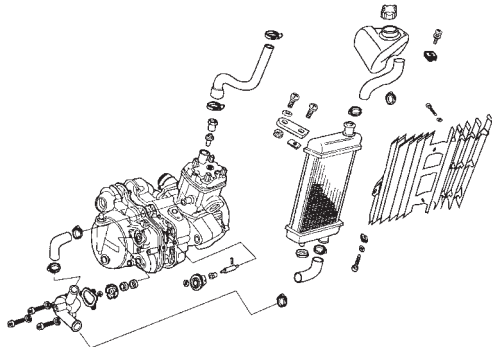

LAMINA / STAMPA / DIAGRAM / BILD / FEUILLE - 24

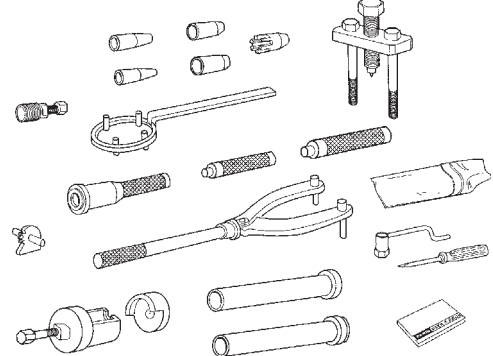



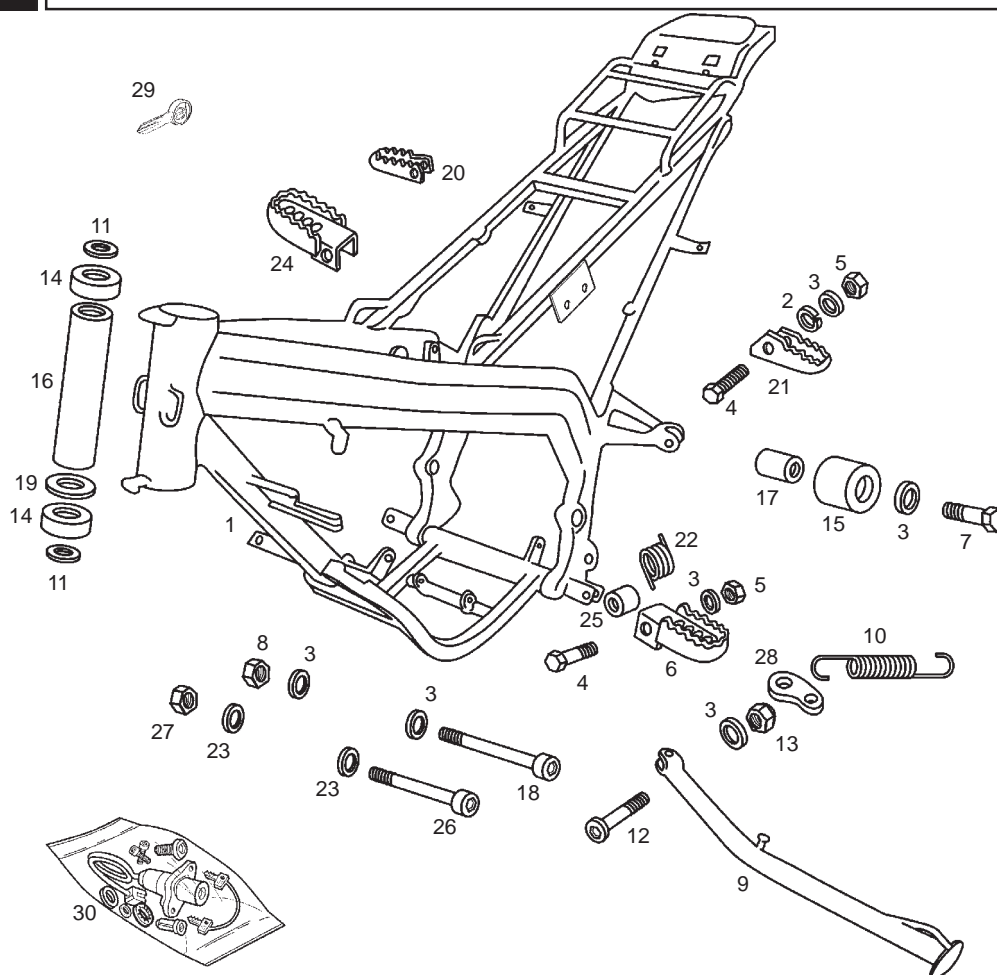

Fig.	Ver.	COD. KOD.	DESCRIPCIÓN DENOMINAZIONE NAME	BEZEICHNUNG DESIGNATION	MOD.	NOTAS NOTES NOTA MITSCHRIFT NOTES
01A		00H01978601	R-CTO. CUADRO C/RDMTOS. TELAIO FRAME	RAHMEN SOUS ENSEMBLE CADRE	1 2 3 4	
02A		00036008000	ARANDELA MUELLE B8 RONDELLA WASHER	SCHEIBE RONDELLE	1 2 3 4	
03A		00402080001	ARANDELA PLANA MECANIZ. D8 RONDELLA WASHER	SCHEIBE RONDELLE	1 2 3 4	
04A		00022084021	TORNILLO C/EXAG. 8M125X40 VITE SCREW	SCHRAUBE VIS	1 2 3 4	
05A		00023108000	TUERCA AUTOBLOC. 8M125. DADO NUT	MUTTER ECROU	1 2 3 4	
06A		00H02201312	SCTO. ESTR. IZ PILOTO ZINC. BL. APPOG. DES. FOOTREST	FUSSRASTER LINKS REPOSE PIED GAUCHE	1 2 3 4	
07A		00022084521	TORNILLO C/EXAG. 8M125X45. VITE SCREW	SCHRAUBE VIS	1 2 3 4	
08A		00262080022	TUERCA AUTOBLOC. 8M125 DADO NUT	MUTTER ECROU	1 2 3 4	
09A		00H00819011	SCTO. PATA CABALLETE ZAMPA CAVALETTO SIDE STAN SUB-ASSY	SEITENSTANDER BEQUILLE LATERALE	1 2 3 4	
10A		00H00803082	MUELLE PATA CABALLETE MOLLA SPRING	FEDER RESSORT	1 2 3 4	
11A		00008902630	ARANDELA TAPON TUBO PNA. RONDELLA WASHER	SCHEIBE RONDELLE	1 2 3 4	



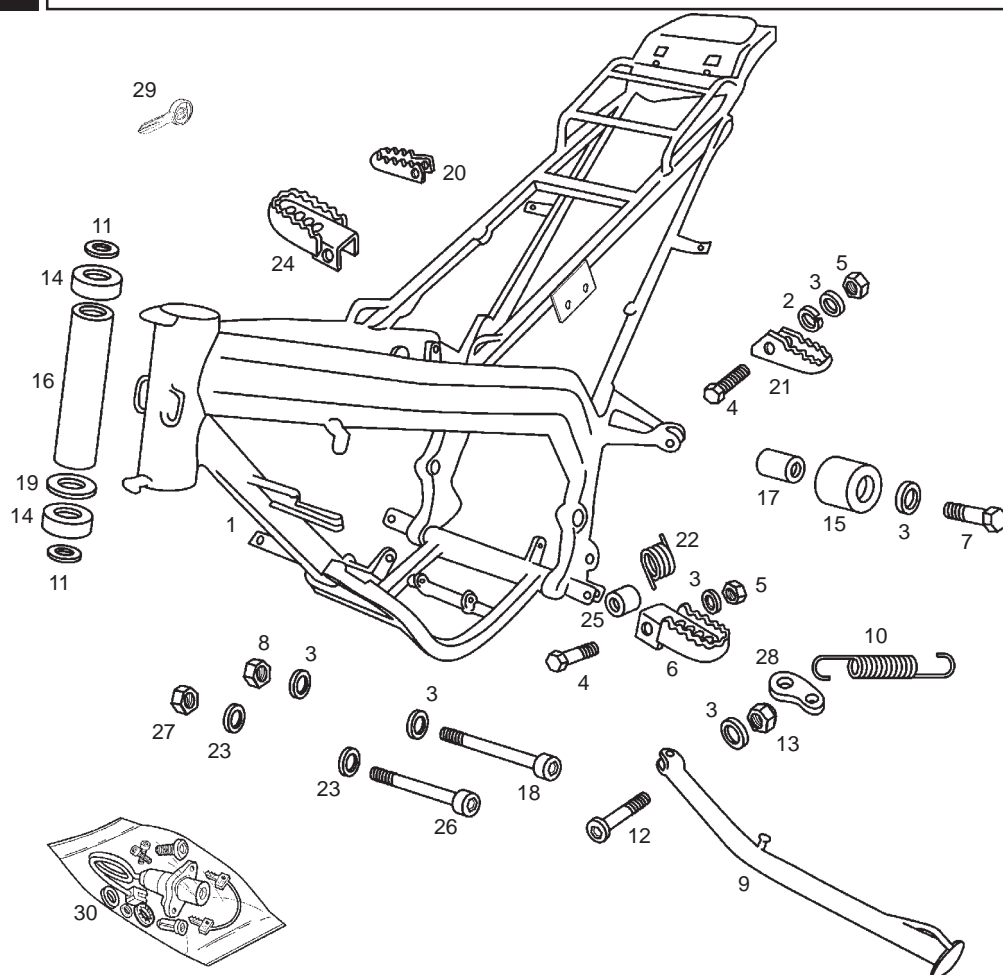

Fig.	Ver.	COD. KOD.	DESCRIPCIÓN DENOMINAZIONE NAME	BEZEICHUNG DESIGNATION	MOD.	NOTAS NOTES NOTA MITSCHRIFT NOTES
12A		00H00805072	TORNILLO FIJ. PATA CABALL. VITE SCREW	SCHRAUBE VIS	1 2 3 4	
13A		00023108000	TUERCA EXAG. 8M125 DADO NUT	MUTTER ECROU	1 2 3 4	
14A		00000056205	COJINETE CUSCINETTO BEARING	LAGER COUSSINET	1 2 3 4	
15A		00H01801771	RODILLO TENSOR CADENA RULLO TENSORE CATENA CHAIN SUPPORTY GUIDE	ROLLE ROULETTE GUIDE CHAINE	1 2 3 4	
16A		00H06303401	TUBO SEPARADOR COJINETES TUBO TUBE	ROHR TUYAU	1 2 3 4	
17A		00002518790	CASQUILLO BRONZINA BUSHING	BUCHSE ENTRETOISE	1 2 3 4	
18A		00H02500272	TORNILLO FIJ. INF. MOTOR ALL.8M125X90 VITE SCREW	SCHRAUBE VIS	1 2 3 4	
19A		00H06500451	ARANDELA COJIN. TUBO DIREC. RONDELLA WASHER	SCHEIBE RONDELLE	1 2 3 4	
20A		00D01520096	ESTRIB. DR. PASAJ. ZIRC. PEDANA DESTRA RIGHT FOOT REST	FUSSRASTER RECHTS REPOSE-PIED DROIT	1 2 3 4	
21A		00D01540456	ESTRIB. IZ. PASAJ. ZIRC. PEDANA SINISTRA LEFT FOOT REST	FUSSRASTER LINKS REPOSE-PIED GAUCHE	1 2 3 4	
22A		00H04903292	MUELLE FIJACION ESTRIBERA MOLLA SPRING	FEDER RESSORT	1 2 3 4	

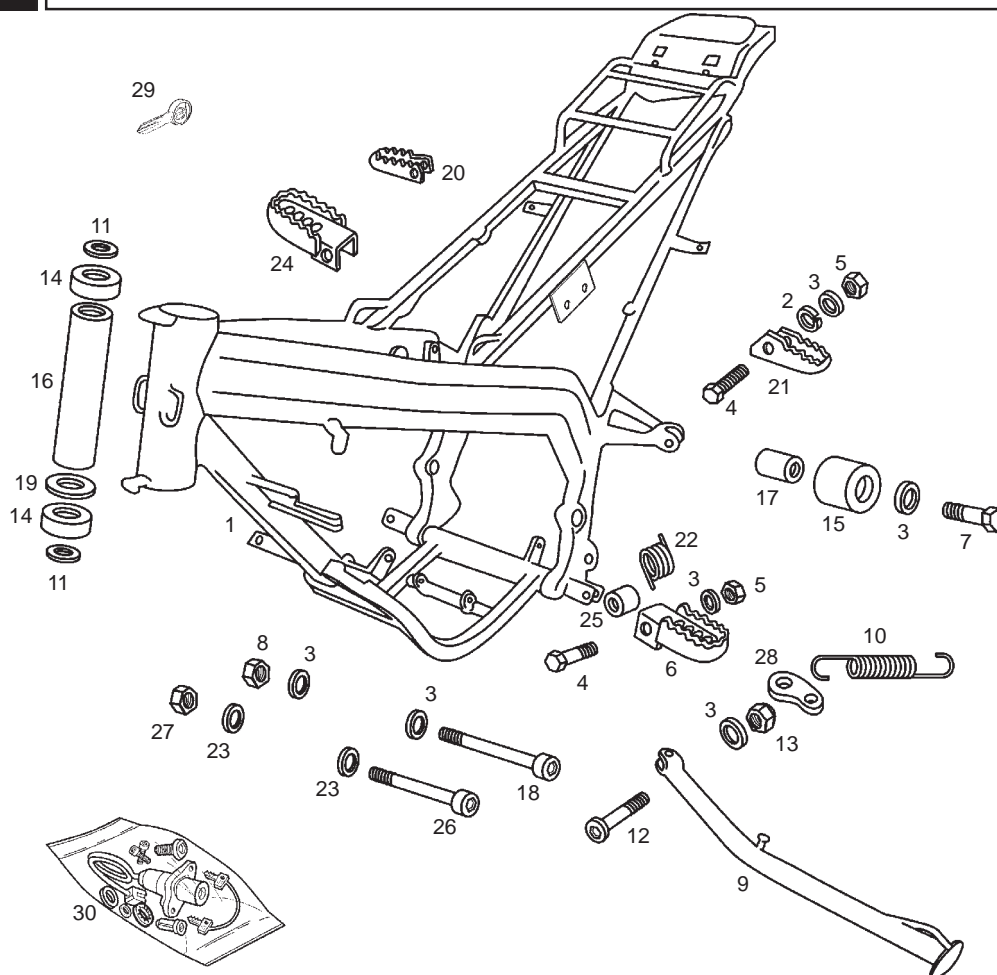

Fig.	Ver.	COD. KOD.	DESCRIPCIÓN DENOMINAZIONE NAME	BEZEICHNUNG DESIGNATION	MOD.	NOTAS NOTES NOTA MITSCHRIFT NOTES
23A		00402100001	ARANDELA PLANA D10 RONDELLA WASHER	SCHEIBE RONDELLE	1 2 3 4	
24A		00H02201302	SCTO. ESTRIB. PILOTO ZINC. BL. APOG. DES. FOOTREST	FUSSRASTER RECHTS REPOSE PIED DROIT	1 2 3 4	
25A		00002215152	CASQUILLO BRONZINA BUSHING	BUCHSE ENTRETOISE	1 2 3 4	
26A		00H03000272	TORNILLO FIJ. DT. MTO. ALL.10M150X100 VITE SCREW	SCHRAUBE VIS	1 2 3 4	
27A		00262100032	TUERCA AUTOBLOC.10M150 DADO NUT	MUTTER ECROU	1 2 3 4	
28A		00H00800422	PLACA RETORNO CABALLETE PIASTRINA RITORNO CAVALLETTA G SPRING KIK-STAND SUPPORT	PLATTE F. GESTELLRUCKFUHRU SUPPORT RESSORT DE BEQUILLE	1 2 3 4	
29A		00F01810411	R-LLAVE CERRADURAS P/MEC. CHIAVE LOCK KEYS	SCHLUSSEL CLEF	1 2 3 4	
30A		00H05908251	CTO. KIT CERRADURAS SIN LEVAS SERRATURE SENZA LEVA LOCK WITH KEYS WITHOUT LEVER	SCHLOOS-SATZ OHNE VERSCHLUSSHEBEL ENS. KIT SERRURES SANS LEVIER	1 2 3 4	

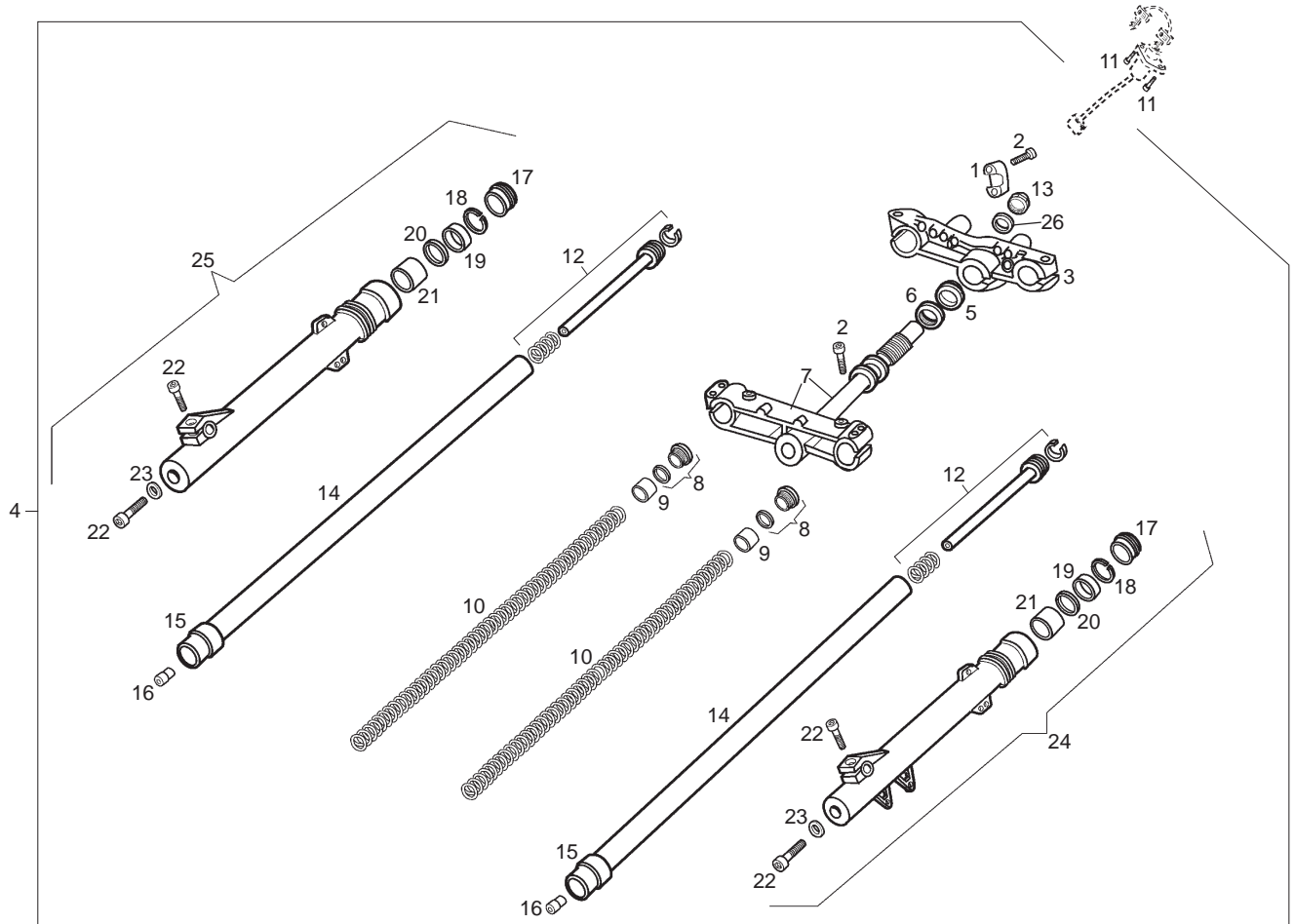

Fig.	Ver.	COD. KOD.	DESCRIPCIÓN DENOMINAZIONE NAME	BEZEICHNUNG DESIGNATION	MOD.	NOTAS NOTES NOTA MITSCHRIFT NOTES
01A		00H00201741	R-PUENTE.FIJ.MANILLAR FLANGIA FISSAGGIO MANUBRIO R.8 HANDLEBAR LOCK CLAMP	BUGEL ETRIER FIX GUIDON	1 2 3 4	
02A		00000004835	TORNILLO C/ALLEN 8M125X35 VITE SCREW	SCHRAUBE VIS	1 2 3 4	
03A		00H00208091	R-PLATINA SUP.HORQ. FLANGIA SUPERIORE FORCELLA G R-UPPER FORK PLATE	E-TEIL OBERE GABELPLATTE R-PLATINE SUPvRIEURE FOURCHE G	1 2 3 4	
04A		00H00220001	CTO. HORQUILLA DIRECTRIZ FORCELLA DIRETT. FORCKASSY	LENKGABEL ENSEMBLE FOURCHE DIRITICE	1 2 3 4	
05A		00D00200761	GUARDAPOLVO DIRECCION PARAPOLVERE STERZO DUST COVER, STEM	ABDECKUNG CACHE POUSSIÈRE DIRECTION	1 2 3 4	
06A		00G00200112	TUERCA FIJACION TIJA DADO NUT	MUTTER ECROU	1 2 3 4	
07A		00H00209011	R-SCTO. TIJA-PLAT. FUSTO PIASTRA LOWER TRIPLE CLAMP, W/PIN ASSY	SATTELSTANGE PLATINE INF. AVEC PIVOT	1 2 3 4	
08A		00H00204271	R-CTO.TAPON PNA.HORQ. TAPPO GAMBA FORCELLA FORK TUBE CAP	PFROPFEN F. GABELSCHENKEL BOUCHON	1 2 3 4	
09A		00H00202151	R-CASQ.GUIA PIERNA HORQ. GHIERA GUIDAGGIO GAMBA FORCE BUSHING	FUHRUNGSBUCHSE GABELSCHENK ENTRETOISE	1 2 3 4	
10A		00H00206171	R-MUELLE HORQ. MOLLA FORCELLA FORK SPRING	GABELFEDER RESSORT DE FOURCHE	1 2 3 4	
11A		00002082021	TORNILLO 8M125X20 VITE SCREW	SCHRAUBE VIS	1 2 3 4	

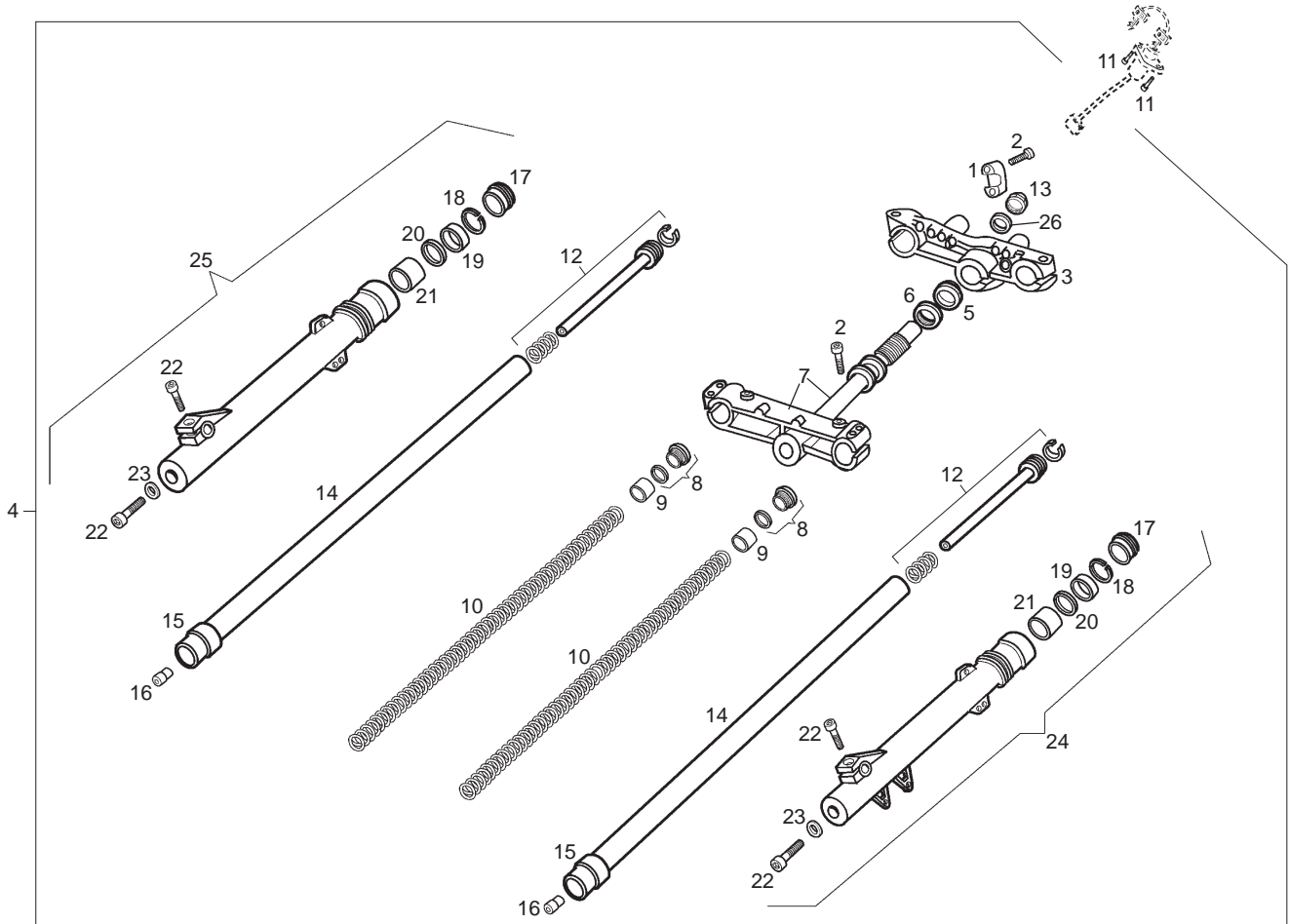

Fig.	Ver.	COD. KOD.	DESCRIPCIÓN DENOMINAZIONE NAME	BEZEICHNUNG DESIGNATION	MOD.	NOTAS NOTES NOTA MITSCHRIFT NOTES
12A		00H00201531	R-CTO. TUBO HIDRAUL. TUBO VALVOLA DAMPER TUBE ASSY.	HYDRAULIKROHR ENSEMBLE TUBE HYDRAULIQUE	1 2 3 4	
13A		00H00201111	TUERCA FIJ.TIJA DADO NUT	MUTTER ECROU	1 2 3 4	
14A		00H00204191	TUBO PRINCIPAL LOBITO TUBO TUBE	ROHR TUYAU	1 2 3 4	
15A		00H00203261	R-CASQ.INT.INF.PNA HORQ.LOBITO GHIERA INTERNA GAMBA FORCELL BUSHING	BUCHSE GABELSCHENKEL ENTRETOISE	1 2 3 4	
16A		00H00202201	R-SUPMT.GUARDAP.HORQ.LOBITO SUPPLEMENTO PARAPOLVERE FORC SUPPLEMENT DUSTGUARD FORK	ZUBEOR STAUBFANGER SUPPLEMENT POUSSIÈRE FOURCHE	1 2 3 4	
17A		00H00202231	R-GUARDAP.HORQ.LOBITO PARAPOLVERE FORCELLA HUNTER DUST PROTECTOR, UPPER FORK	RSTAUBFANGER F. GABEL CACHE POUSSIÈRE	1 2 3 4	
18A		00H00200701	R-ANILLO RETENC.ACEITE LOBITO ANELLO DI FERMO STOP RING	INBUSSCHRAUBE 6M100X25 VIS A TÊTE ALLEN 6M100X25	1 2 3 4	
19A		00H00203471	R-CASQ.RETENC.ACEITE LOBITO GIUNTO TENUTA GAMBA FORCELLA SEAL, FORK TUBE.	DICHTRING JOINT SPI FOURCHE	1 2 3 4	
20A		00H00201441	R-ARAND.CASQ.GUIA PNA.HORQ.LOB ANELLO TORICO TAPPO INFERIOR O RING	RING PFROPFENSCHRAUBE JOINT	1 2 3 4	
21A		00H00201581	R-CASQ.GUIA MUELLE HORQ.LOBITO GUIDA MOLLA FORCELLA SPRING FORK GUIDE	FUHRUNG F. GABELFEDER GUIDE RESSORT FOURCHE	1 2 3 4	
22A		00000004625	TORNILLO C/ALLEN 6M100X25 VITE SCREW	SCHRAUBE VIS	1 2 3 4	

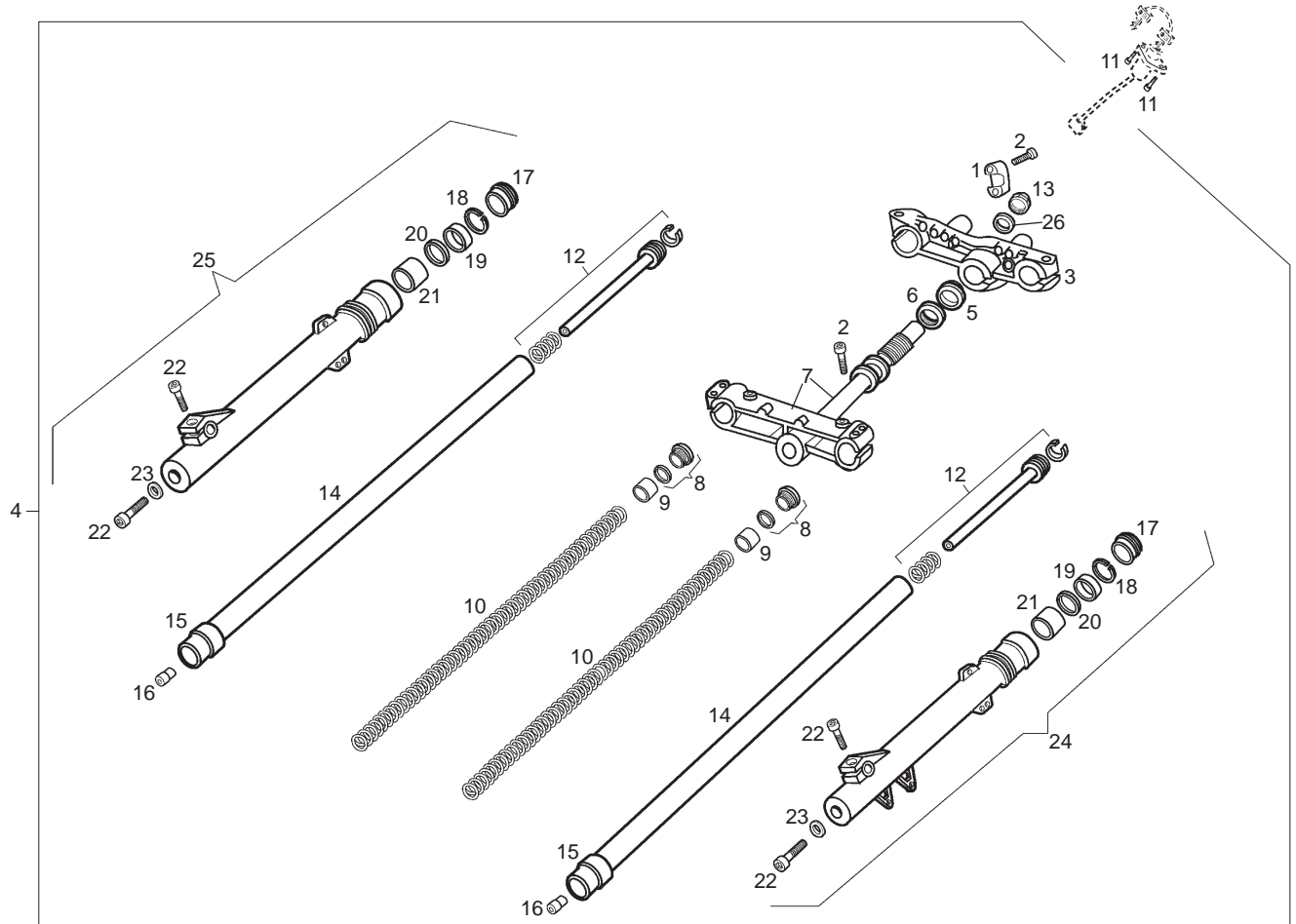

Fig.	Ver.	COD. KOD.	DESCRIPCIÓN DENOMINAZIONE NAME	BEZEICHNUNG DESIGNATION	MOD.	NOTAS NOTES NOTA MITSCHRIFT NOTES
23A		00000031060	ARANDELA PLANA MECANIZ.D.6 RONDELLA WASHER	SCHEIBE RONDELLE	1 2 3 4	
24A		00H02008031	R-CTO.TUBO PNA IZ.HORQ.LOBITO ASTA SINISTRA FORK TUBE LOWER LEFT ASSY	GABELBEIN LINKS ENSEMBLE BRANCHE GAUCHE	1 2 3 4	
25A		00H02008041	R-CTO.TUBO PNA DR.HORQ.LOBITO ASTA DESTRA FORKTUBE LOWER RIGHTASSY	GABELBEIN RECHTS BRANCHE DROITE ENSEMBLE	1 2 3 4	
26A		00H00202101	ARANDELA FIJ.TIJA RONDELLA WASHER	SCHEIBE RONDELLE	1 2 3 4	

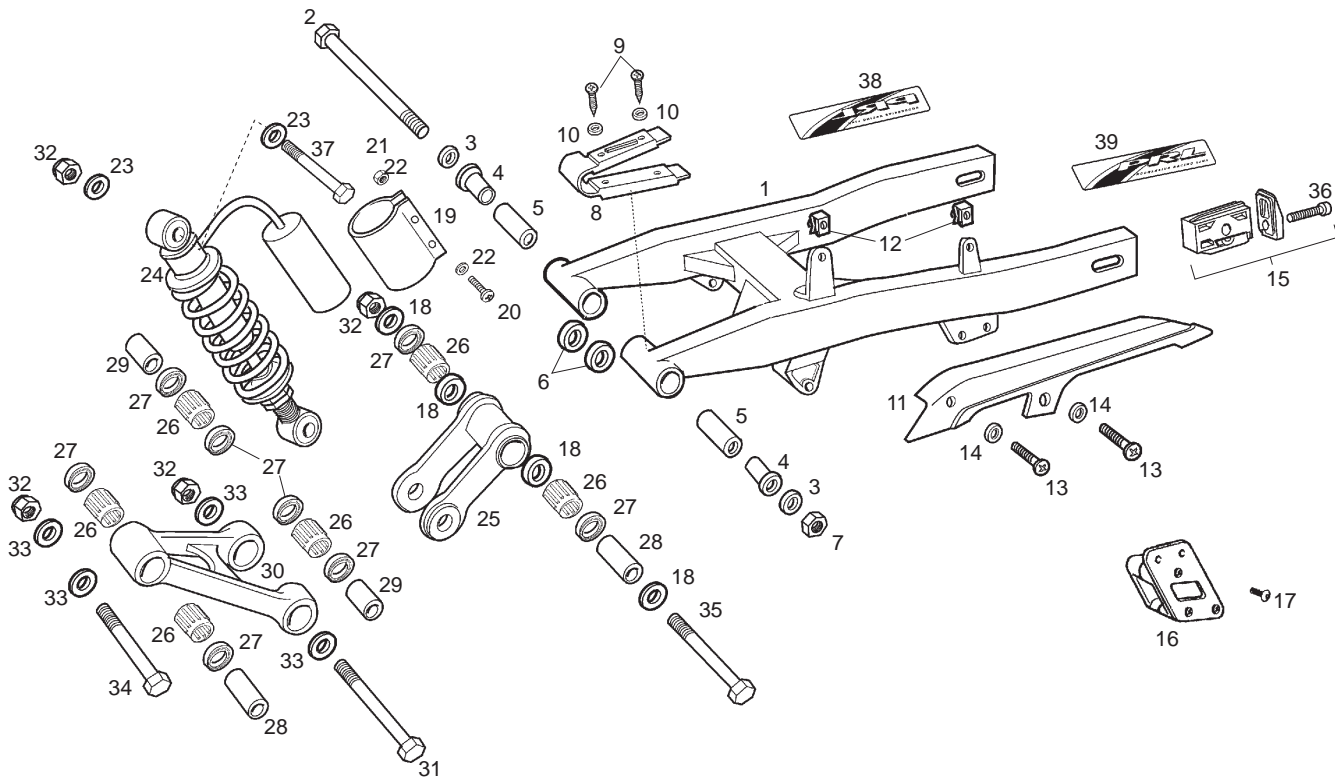

Fig.	Ver.	COD. KOD.	DESCRIPCIÓN DENOMINAZIONE NAME	BEZEICHNUNG DESIGNATION	MOD.	NOTAS NOTES NOTA MITSCHRIFT NOTES
01A		00H00325971	R-SCTO BASCULANTE C/CASQUILLO RIBALTABILE SWING ARM SUB-ASSY	SCHWINGENACHSE BRAS OSCILLANT	1 2 3 4	
02A		00H01304202	SCTO.EJE BASCTE.C-4. ASSE RIBALTABILE SWING ARM SUB-ASSEMBLY	HINTERRADACHSE AXE DE BRAS OSCILLANT	1 2 3 4	
03A		00003112322	ARANDELA EJE RUEDA RONDELLA WASHER	SCHEIBE RONDELLE	1 2 3 4	
04A		00002503230	CASQUILLO BRONZINA BUSHING	BUCHSE ENTRETOISE	1 2 3 4	
05A		00H00301401	CASQUILLO BRONZINA BUSHING	BUCHSE ENTRETOISE	1 2 3 4	
06A		00D01300192	ARANDELA EJE RONDELLA WASHER	SCHEIBE RONDELLE	1 2 3 4	
07A		00262120032	TUERCA AUTOBLOC. 12M150 DADO NUT	MUTTER ECROU	1 2 3 4	
08A		00H01804331	PLACA ROZAMTO.CADENA PIASTRA ATTRITO CATENA CHAIN FORCHIN PLATE/FLARGE	KETTEN-REIBPLATTE PLAQUE GLISSEMENT CHAINE	1 2 3 4	
09A		00011141300	TORNILLO AUT. C/C R. N G.4,8X13. VITE SCREW	SCHRAUBE VIS	1 2 3 4	
10A		00000031050	ARANDELA D5 RONDELLA WASHER	SCHEIBE RONDELLE	1 2 3 4	
11A		00H01508181	CUBRECADENA COPRICATENA CHAIN COVER	KETTENSCHUTZ COUVRE CHAINE	1 2 3 4	

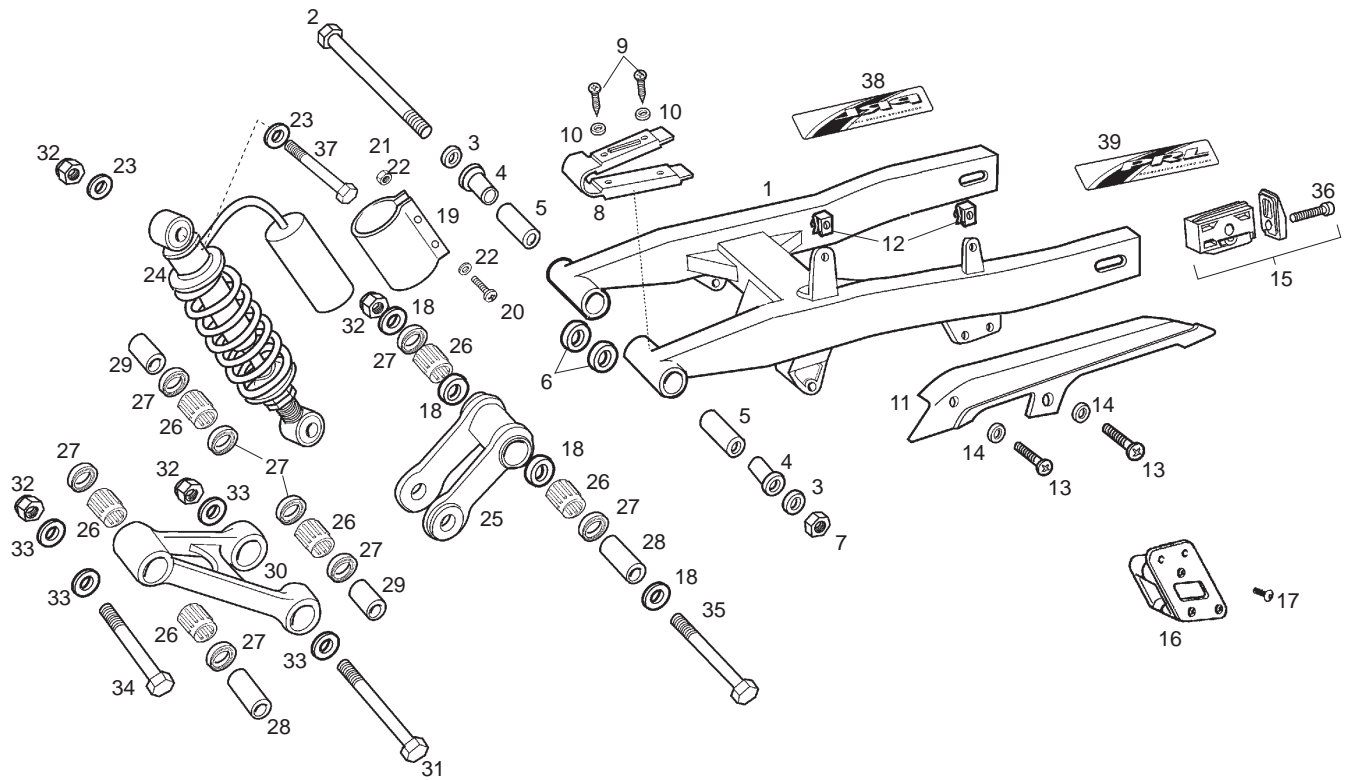

Fig.	Ver.	COD. KOD.	DESCRIPCIÓN DENOMINAZIONE NAME	BEZEICHNUNG DESIGNATION	MOD.	NOTAS NOTES NOTA MITSCHRIFT NOTES
12A		00D01501371	TUERCA FIJ. CUBRECADENA DADO NUT	MUTTER ECROU	1 2 3 4	
13A		00012061200	TORNILLO C/CRUZ NG 6M100X12 VITE SCREW	SCHRAUBE VIS	1 2 3 4	
14A		00D01200171	ARANDELA EJE LEVA-FIJ.CUBRECAD. RONDELLA WASHER	SCHEIBE RONDELLE	1 2 3 4	
15A		00H01304811	R-CTO.TENSOR RUEDATR. TENSORE RUOTA ADJUSTER, REAR WHEELASSY	HINTERRADSPANNER TENDEUR DE ROUE ENSEMBLE	1 2 3 4	
16A		00H01502871	CTO GUIA CADENA GUIDA CATENA CHAIN GUIDE	GLEITBAHN GUIDE CHAINE	1 2 3 4	
17A		00012061000	TORNILLO C/REDONDA 6X10 VITE SCREW	SCHRAUBE VIS	1 2 3 4	
18A		00001213190	CASQUILLO BRONZINA BUSHING	BUCHSE ENTRETOISE	1 2 3 4	
19A		00H02201521	BRIDA BRIGLIA BRIDLE	ZÜGEL BRIDE	1 2 3 4	
20A		00012063000	TORNILLO 6X30 VITE SCREW	SCHRAUBE VIS	1 2 3 4	
21A		00000021060	TUERCA EXAG. 6M100 DADO NUT	MUTTER ECROU	1 2 3 4	
22A		00000031070	ARANDELA M7 RONDELLA WASHER	SCHEIBE RONDELLE	1 2 3 4	



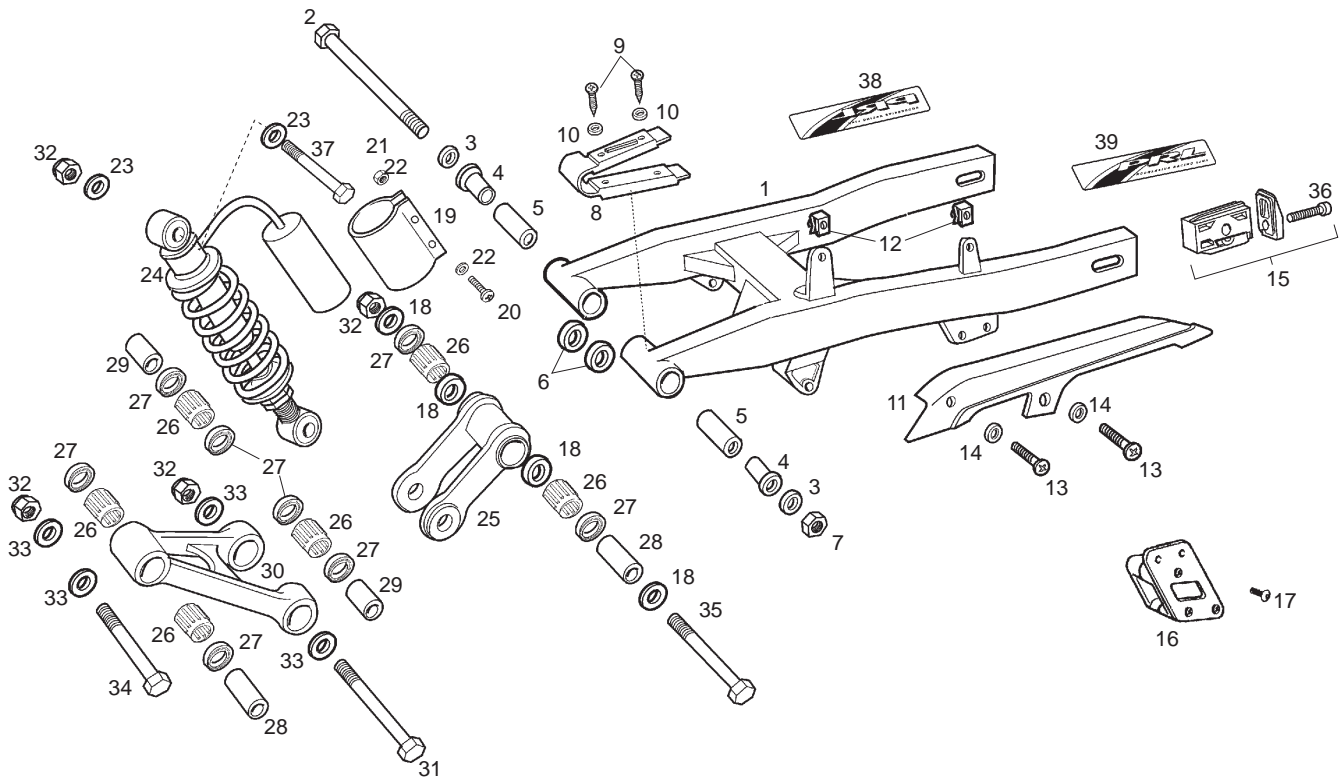

Fig.	Ver.	COD. KOD.	DESCRIPCIÓN DENOMINAZIONE NAME	BEZEICHUNG DESIGNATION	MOD.	NOTAS NOTES NOTA MITSCHRIFT NOTES
23A		00003115422	ARANDELA RONDELLA WASHER	SCHEIBE RONDELLE	1 2 3 4	
24A		00H01511191	CTO.AMORTIGUADOR AMMORTIZZATORE SHOCK ABSORBER	FEDERBEIN AMORTISSEUR	1 2 3 4	
25A		00H00301801	SCTO.BIELA ARTICUL. SCTO.BIELA ARTICUL. SUSPENSION LINKS ARTICULATION	U-GRUPPE ANGELENKTES PLEUEL S/ENSEMBLE BIELLE ARTICULATION	1 2 3 4	
26A		00H00301701	JAULA AGUJAS BIELETAS GABBIA SPILLI BIELLETTE SUSPENSION LINKS NEEDLE BEARING	NADELK < FIG PLEUEL CAGE AIGUILLES BIELLETTES	1 2 3 4	
27A		00H00301871	RETEN JAULA AGUJAS BIELETAS GIUNTO TENUTA SEAL	DICHTRING JOINT	1 2 3 4	
28A		00H00301851	CASQUILLO BRONZINA BUSHING	BUCHSE ENTRETOISE	1 2 3 4	
29A		00H00301861	CASQUILLO BRONZINA BUSHING	BUCHSE ENTRETOISE	1 2 3 4	
30A		00H00301831	SCTO.BIELA TRIANG.ARTIC. BIELLA TRIANGOLO SUSPENSION TRIANGULATION LINKS	U-GRUPPE ANGELENKTE TRIANGULA S/ENSEMBLE BIELLE TRIANGLE ART	1 2 3 4	
31A		00H00300891	TORNILLO FIJ. AMORT. 12M175X110 VITE SCREW	SCHRAUBE VIS	1 2 3 4	
32A		00023112000	TUERCA AUTOBLOC. 12M175 DADO NUT	MUTTER ECROU	1 2 3 4	
33A		00H01500421	ARANDELA FIJ. INF. AMORT. RONDELLA WASHER	SCHEIBE RONDELLE	1 2 3 4	

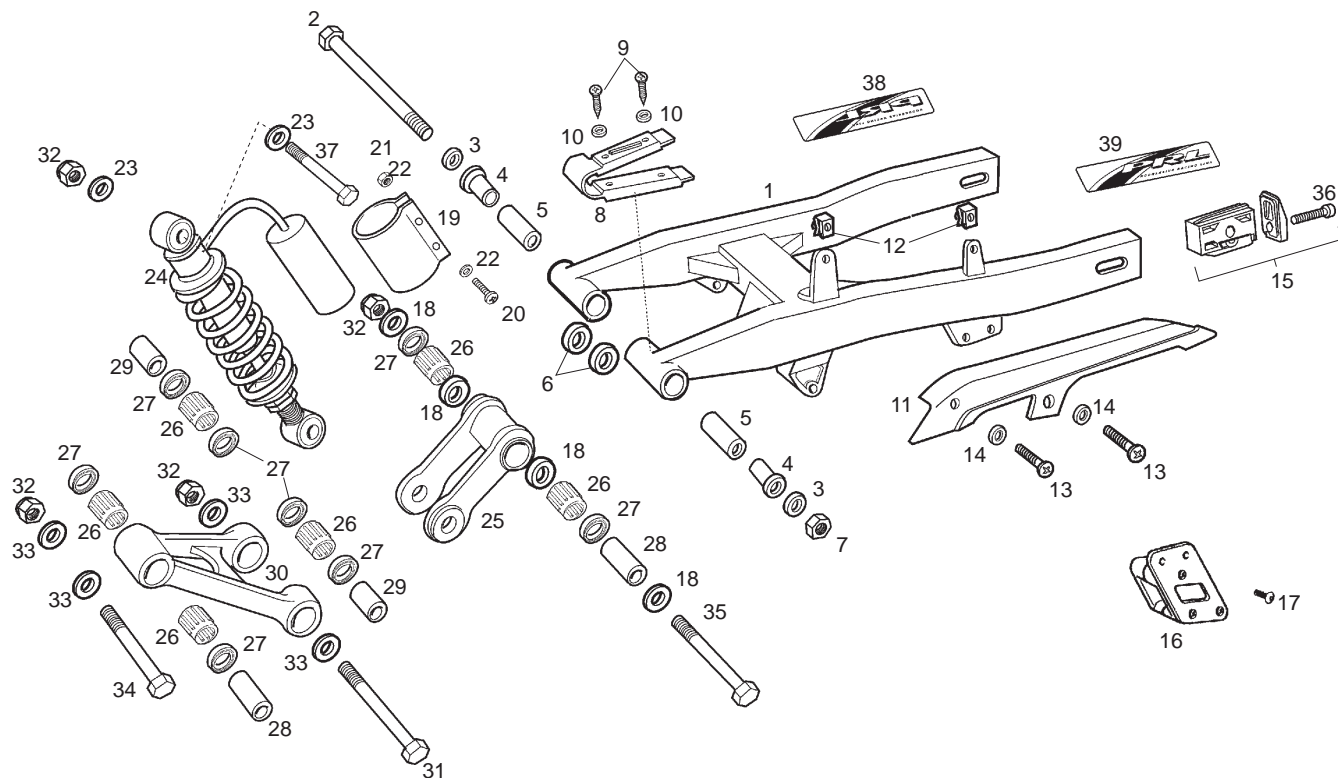

Fig.	Ver.	COD. KOD.	DESCRIPCIÓN DENOMINAZIONE NAME	BEZEICHNUNG DESIGNATION	MOD.	NOTAS NOTES NOTA MITSCHRIFT NOTES
34A		00H06800471	TG R. FIJ. B I ELA AMORT.12M175X70 VITE FISSAGGIO BIELLAAMMORTIZ. SHOCK ABSORBER ARM SECURING SC	BEFESTIGUNGSSCHRAUBE STOSSD VIS FIXATION BIELLE AMORTISSEU	1 2 3 4	
35A		00031120123	TORNILLO FIJ. BI ELETAS VITE SCREW	SCHRAUBE VIS	1 2 3 4	
36A		00H01301491	TORNILLO C/ALLEN M8X50 VITE SCREW	SCHRAUBE VIS	1 2 3 4	
37A		00H00303892	TORNILLO 12M175X58 ZB VITE SCREW	SCHRAUBE VIS	1 2 3 4	
38A		00H00310331	CALCA BASCULANTE DECALCO RIBALTABILE DECAL	ABZIEHBILD ADHESIF	1 2 3 4	
39A		00H00302621	CALCA BASCULANTE DECALCO RIBALTABILE DECAL	ABZIEHBILD ADHESIF	1 2 3 4	

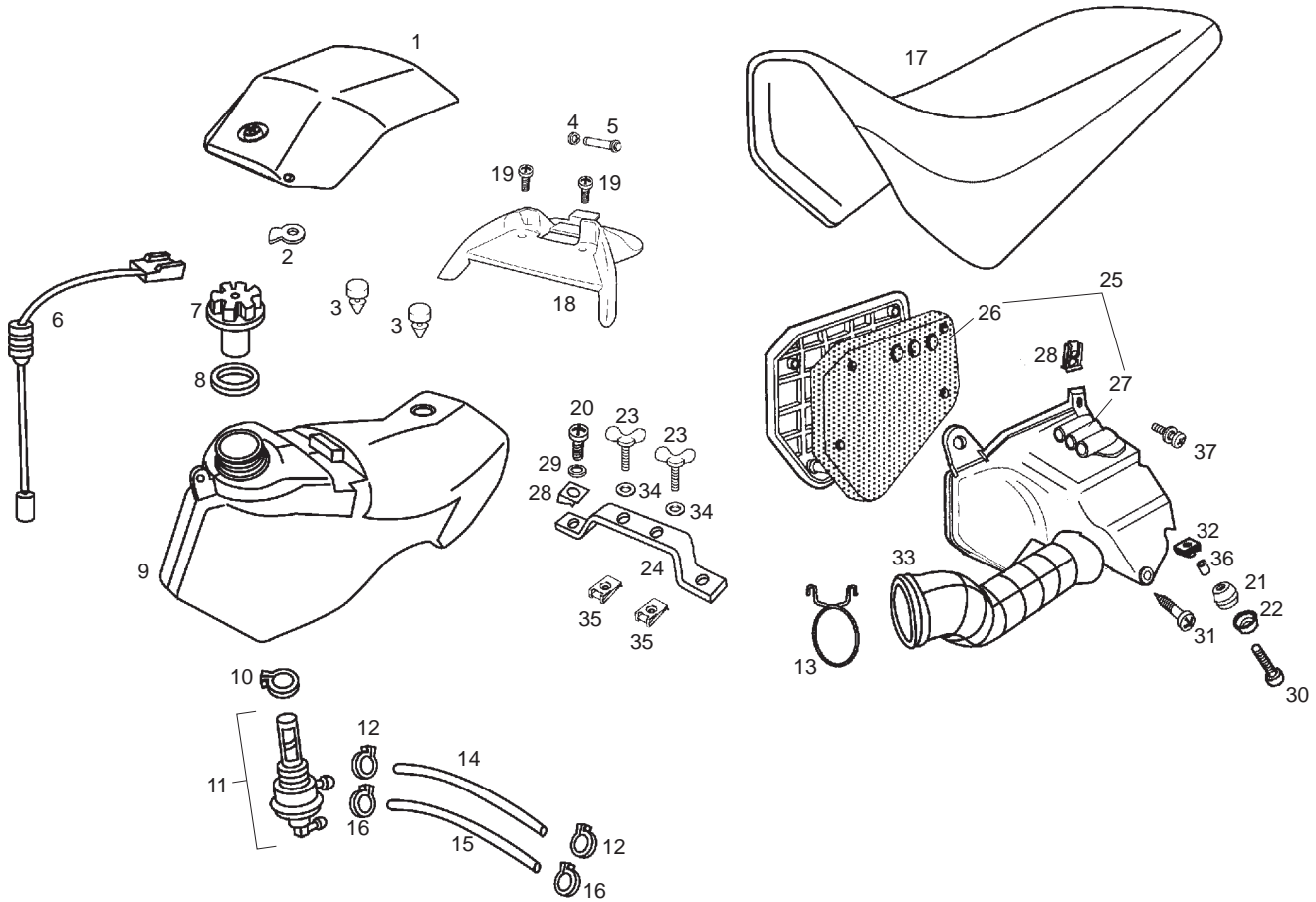

Fig.	Ver.	COD. KOD.	DESCRIPCIÓN DENOMINAZIONE NAME	BEZEICHNUNG DESIGNATION	MOD.	NOTAS NOTES NOTA MITSCHRIFT NOTES
01A		00H00415681	TAPA SUP. DEPÓSITO COPERCHIO COVER	DECKEL COUVERCLE	1 2 3 4	
02A		00H00604141	PALANCA CIERRE LEVA LEVER	SCHLOSS-VERSCHLUSSHEBEL LEVIER FERMETURE SELLE	1 2 3 4	
03A		00G01401321	TOPE GOMA GOMMA RUBBER	GUMMISTOPPEL CAOUTCHOUC	1 2 3 4	
04A		00047030400	ANILLO SEGURIDAD EJES D4 ANELLO SICUREZZA CIRCLIP	SICHERHEITSRING ANNEAU SECURITE	1 2 3 4	
05A		00H06303752	EJE ARTIC. TAPA DEPOS. GASOLINA ASSE ARTIC. COPERC. SUP. SERB. AXLE	STIFT AXE	1 2 3 4	
06A		00H04302181	CTO. NIVEL GASOLINA LIVELLO BENZINA SEND GAS LEVEL SENSOR ASSY.	KRAFTSTOFFSTAND ENSEMBLE FLOTTEUR ESSENCE	1 2 3 4	
07A		00F00400131	CTO. TAPON DEPTO. GASOLINA V. BOX TAPPO SERBATOIO BENZINA FUEL TANK CAP ASSY	FUEL TANK CAP ASSY ENS. BOUCHON RESERV. ESSENCE V.B	1 2 3 4	
08A		00F00400771	R-ARAND. TAPON DEPOSITO RONDELLA TAPPO SERBATOIO FUEL TANK CAP WASHER	SCHEIBE F. TANKDECKEL R-RONDELLE BOUCHON RESERVOI	1 2 3 4	
09A		00H00410011	DEPOSITO GASOLINA SERBATOIO BENZINA FUEL TANK	BENZINTANK RESERVOIR ESSENCE	1 2 3 4	
10A		00G00400501	ABRAZADERA FASCETTA CLAMP	KLAMMER CRAMPON	1 2 3 4	
11A		00G00400181	CTO. GRIFO GASOLINA RUBINETTO BENZINA FUEL COCK ASSY	KRAFTSTOFFHAHN UNTERDRUCK ENSEMBLE ROBINET ESSENCE	1 2 3 4	

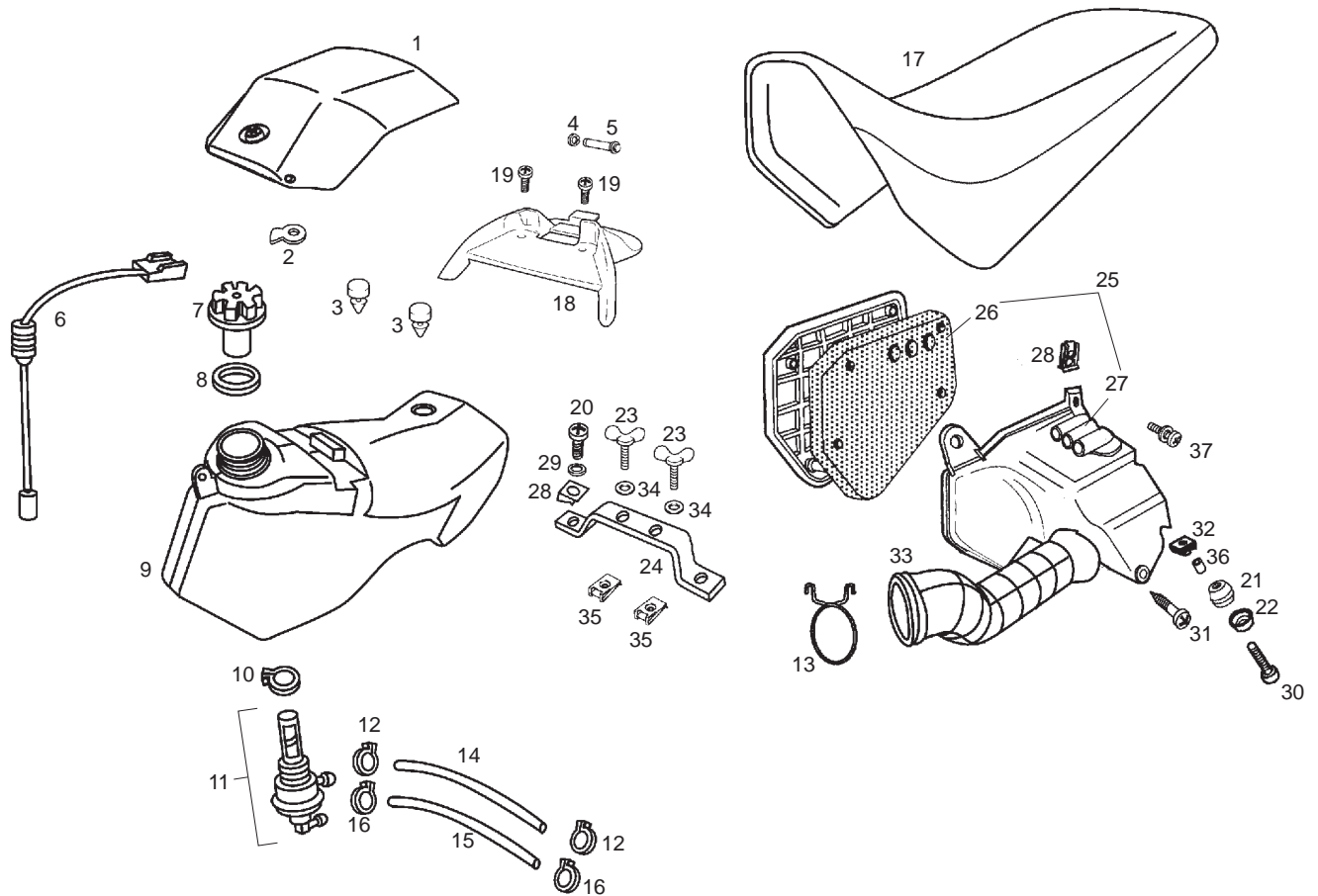

Fig.	Ver.	COD. KOD.	DESCRIPCIÓN DENOMINAZIONE NAME	BEZEICHUNG DESIGNATION	MOD.	NOTAS NOTES NOTA MITSCHRIFT NOTES
12A		00D03700131	ABRAZADERA ELASTICA FASCETTA CLAMP	KLAMMER CRAMPON	1 2 3 4	
13A		00G03204272	MUELLE TUBO ADMISION MOLLA SPRING	FEDER RESSORT	1 2 3 4	
14A		00F00403321	TUBO GASOLINA TUBO TUBE	ROHR TUYAU	1 2 3 4	
15A		00H06201061	TUBO DEPRESION TUBO TUBE	ROHR TUYAU	1 2 3 4	
16A		00F03710131	ABRAZADERA ELASTICA FASCETTA CLAMP	KLAMMER CRAMPON	1 2 3 4	
17A		00H00625011	CTO. SILLIN COMP.SELLINO SEAT	SITZBANK SELLE	1 2	
17B		00H00625012	CTO. SILLIN COMP.SELLINO SEAT	SITZBANK SELLE	3 4	
18A		00H00606021	SUPLEMENTO BASE SILLIN SUPPLEMENTO SELLINO SEAT SUPPLEM.	ZUBEHOR SITZBANK SUPL.SELLE	1 2 3 4	
19A		00011051401	TORNILLO AUTOROSCANTE.5,1X14 NG VITE SCREW	SCHRAUBE VIS	1 2 3 4	
20A		00012061200	TORNILLO C/CR. 6 M 100 X 12 VITE SCREW	SCHRAUBE VIS	1 2 3 4	
21A		00008915020	PROTECCION CABLES PROTEZIONE CAVI RUBBER, CABLE PROTECTOR	GUMMI PASSE-CABLE	1 2 3 4	

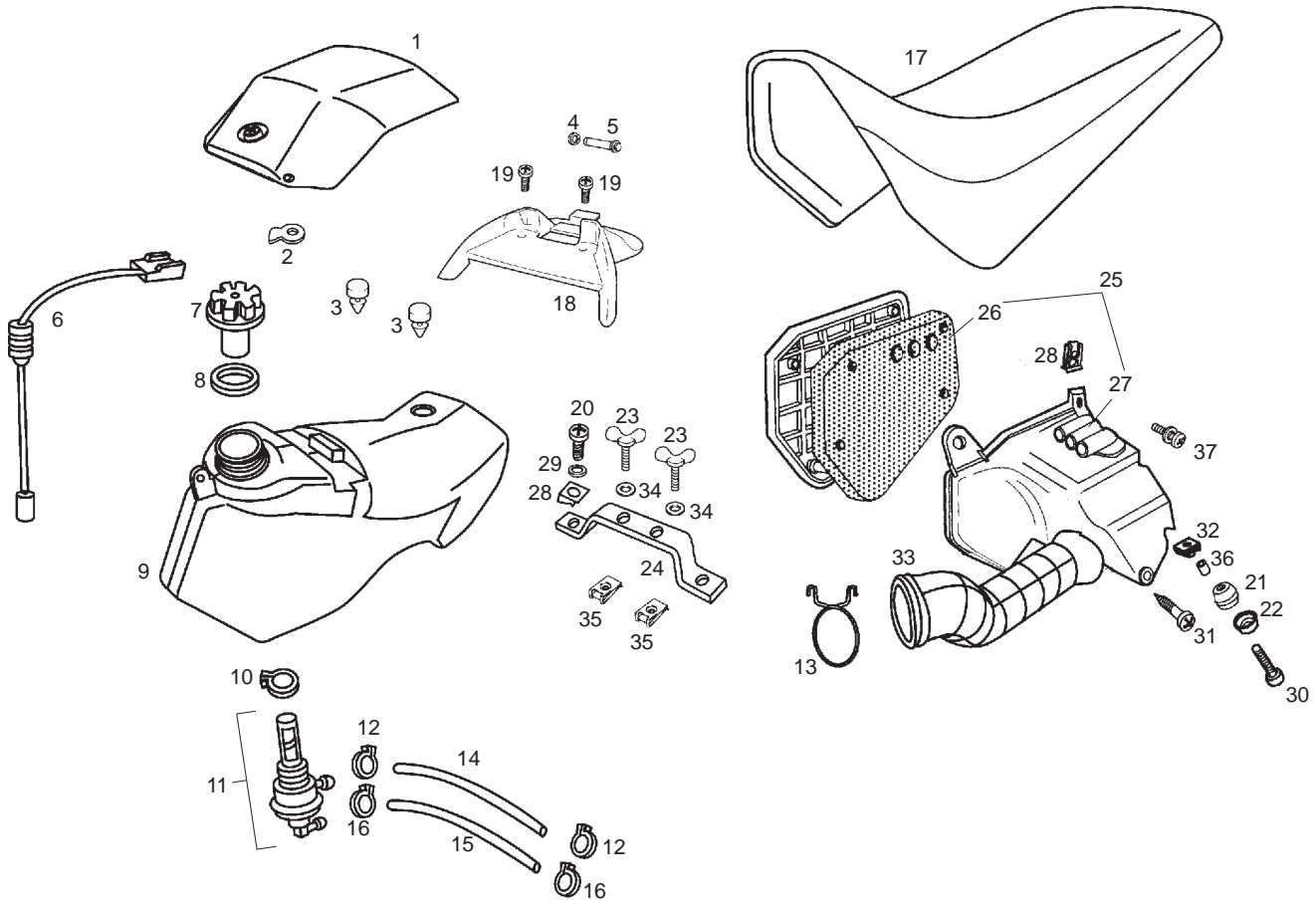

Fig.	Ver.	COD. KOD.	DESCRIPCIÓN DENOMINAZIONE NAME	BEZEICHNUNG DESIGNATION	MOD.	NOTAS NOTES NOTA MITSCHRIFT NOTES
22A		00D01500552	CAZLTA. FIJ. SILENC. SCADELLINO FISSAGGIO HOUSING	ABDECKSCHEIBE CUVETTE	1 2 3 4	
23A		00H06102251	CTO.CIERRE REPIDO CHIUSURA SELLINO LOCKING ASSY	SCHOLSS ENSEMBLE SERRURE	1 2 3 4	
24A		00H00404051	PUNTE FIJ. DPSTO. SUPPORTO INF. SERBATOIO LOWER FUEL TANK BRACKET	LOWER FUEL TANK BRACKET GPRÈRÈ SUPPORT INFËRIEUR RËSERVOIR ES	1 2 3 4	
25A		00H01800541	CTO.CAJA FILTRO CASSA FILTRO AIR FILTER BOX	FILTERKASTEN ENSEMBLE BOITE FILTRE	1 2 3 4	
26A		00H03201251	ESPUMA FILTRO AIRE ESPANSO FILTRO ARIA AIR FILTER MESH	LUFTFILTERSCHAUM FILTRE AIR	1 2 3 4	
27A		00D03210491	TUBO ASPIRACION TUBO TUBE	ROHR TUYAU	1 2 3 4	
28A		00D01501371	TUERCA FIJ. CUBRECADENA DADO NUT	MUTTER ECROU	1 2 3 4	
29A		00D01200171	ARANDELA EJE LEVA-FIJ.CUBRECAD. RONDELLA WASHER	SCHEIBE RONDELLE	1 2 3 4	
30A		00012161600	TORNILLO 6M100X16 VITE SCREW	SCHRAUBE VIS	1 2 3 4	
31A		00073481964	TORNILLO AUTR.C/CRUZ 4,8 X 19 VITE SCREW	SCHRAUBE VIS	1 2 3 4	
32A		00D01501371	TUERCA FIJACION DADO NUT	MUTTER ECROU	1 2 3 4	

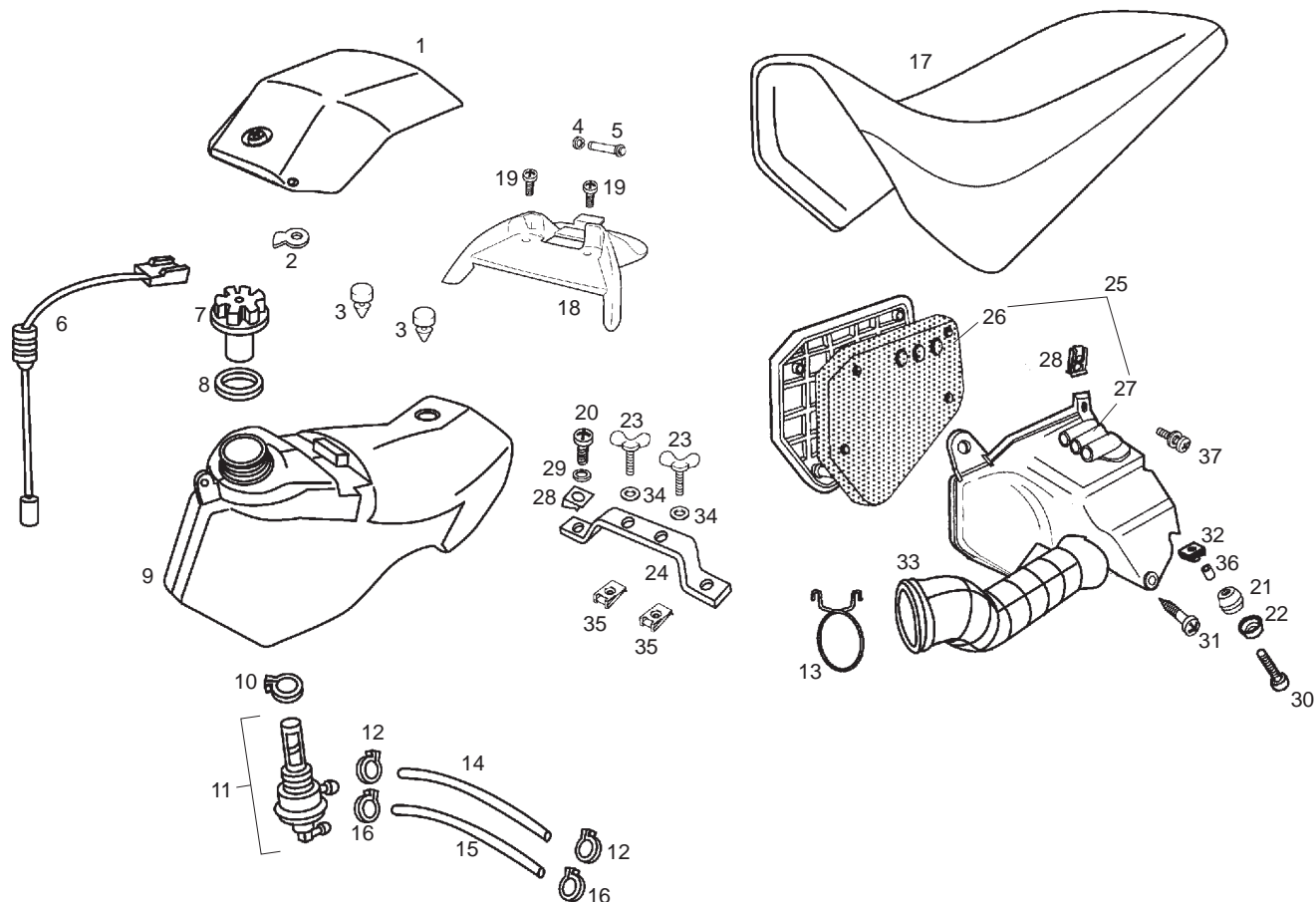

Fig.	Ver.	COD. KOD.	DESCRIPCIÓN DENOMINAZIONE NAME	BEZEICHNUNG DESIGNATION	MOD.	NOTAS NOTES NOTA MITSCHRIFT NOTES
33A		00H03207261	TUBO ADMISION TUBO TUBE	ROHR TUYAU	1 2 3 4	
34A		00D01200171	ARANDELA PLANA RONDELLA WASHER	SCHEIBE RONDELLE	1 2 3 4	
35A		00H01500691	TUERCA DADO NUT	MUTTER ECROU	1 2 3 4	
36A		00D01500471	CASQUILLO BRONZINA BUSHING	BUCHSE ENTRETOISE	1 2 3 4	
37A		00H05900021	SCTO.TORNILLO 6M100X16 VITE SCREW	SCHRAUBE VIS	1 2 3 4	

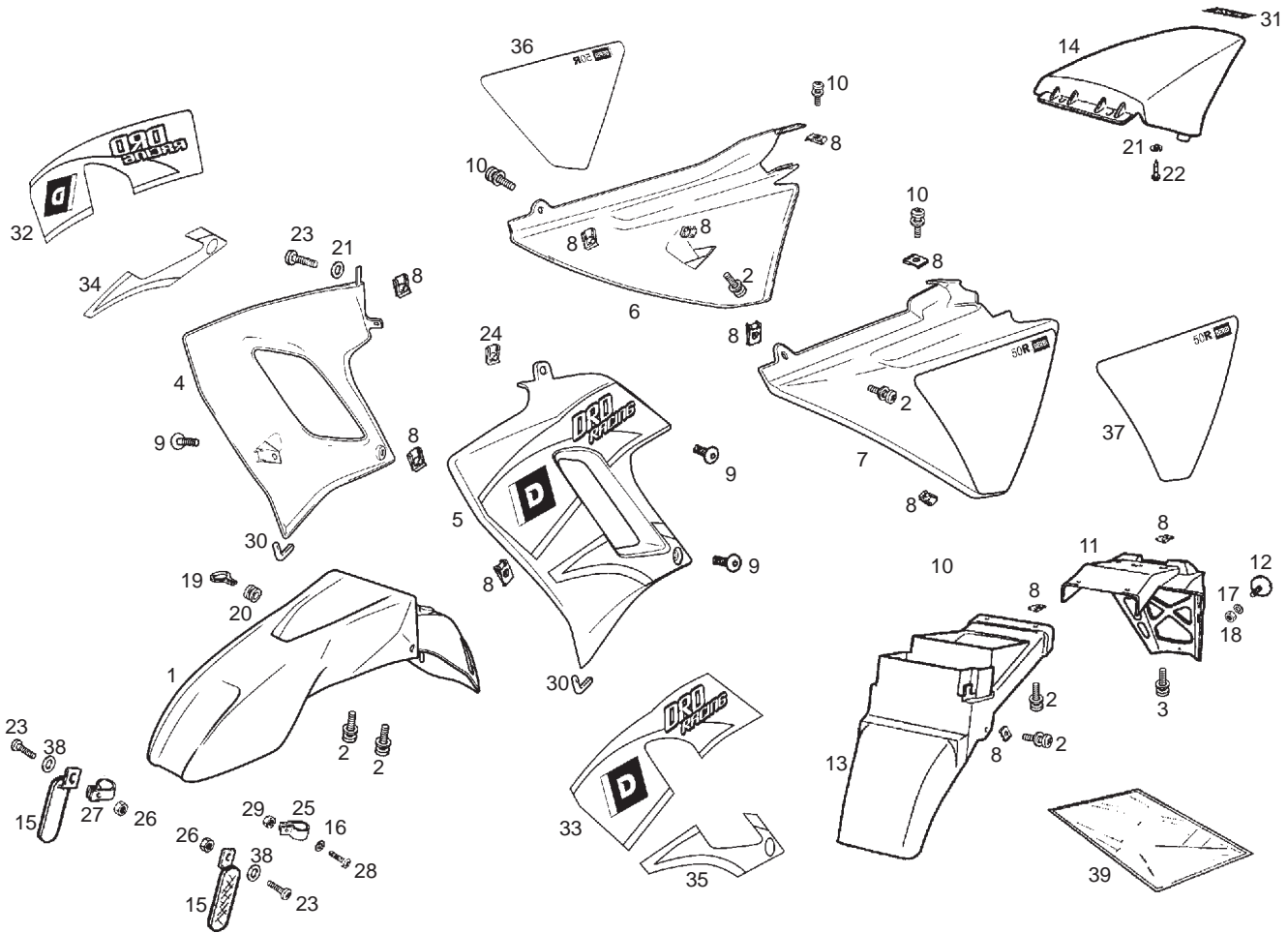

Fig.	Ver.	COD. KOD.	DESCRIPCIÓN DENOMINAZIONE NAME	BEZEICHNUNG DESIGNATION	MOD.	NOTAS NOTES NOTA MITSCHRIFT NOTES
01A		00H00721021	GUARDABARRO DT PARAFANGO ANTERIORE FRONT MUDGUARD ASSY	KOTFLUGEL VORN GARDE-BOUE AVANT RGE	1 2	
01B		00H00721023	GUARDABARRO DT PARAFANGO ANTERIORE FRONT MUDGUARD ASSY	KOTFLUGEL VORN GARDE-BOUE AVANT RGE	3 4	
02A		00H05900021	SCTO.TORNILLO 6M100X16 VITE SCREW	SCHRAUBE VIS	1 2 3 4	
03A		00012061200	SCTO.TORNILLO 6M100X12 VITE SCREW	SCHRAUBE VIS	1 2 3 4	
04A		00H04415771	TAPA DELANTERA DERECHA COPERCHIO COVER	DECKEL COUVERCLE	1 2	
04B		00H04415772	TAPA DELANTERA DERECHA COPERCHIO COVER	DECKEL COUVERCLE	3 4	
05A		00H04415781	TAPA DELANTERA IZQUIERDA COPERCHIO COVER	DECKEL COUVERCLE	1 2	
05B		00H04415782	TAPA DELANTERA IZQUIERDA COPERCHIO COVER	DECKEL COUVERCLE	3 4	
06A		00H00554691	TAPA LAT. DR. COPERCHIO COVER	DECKEL COUVERCLE	1 2 3 4	
07A		00H00554701	TAPA LAT. IZ. COPERCHIO COVER	DECKEL COUVERCLE	1 2 3 4	



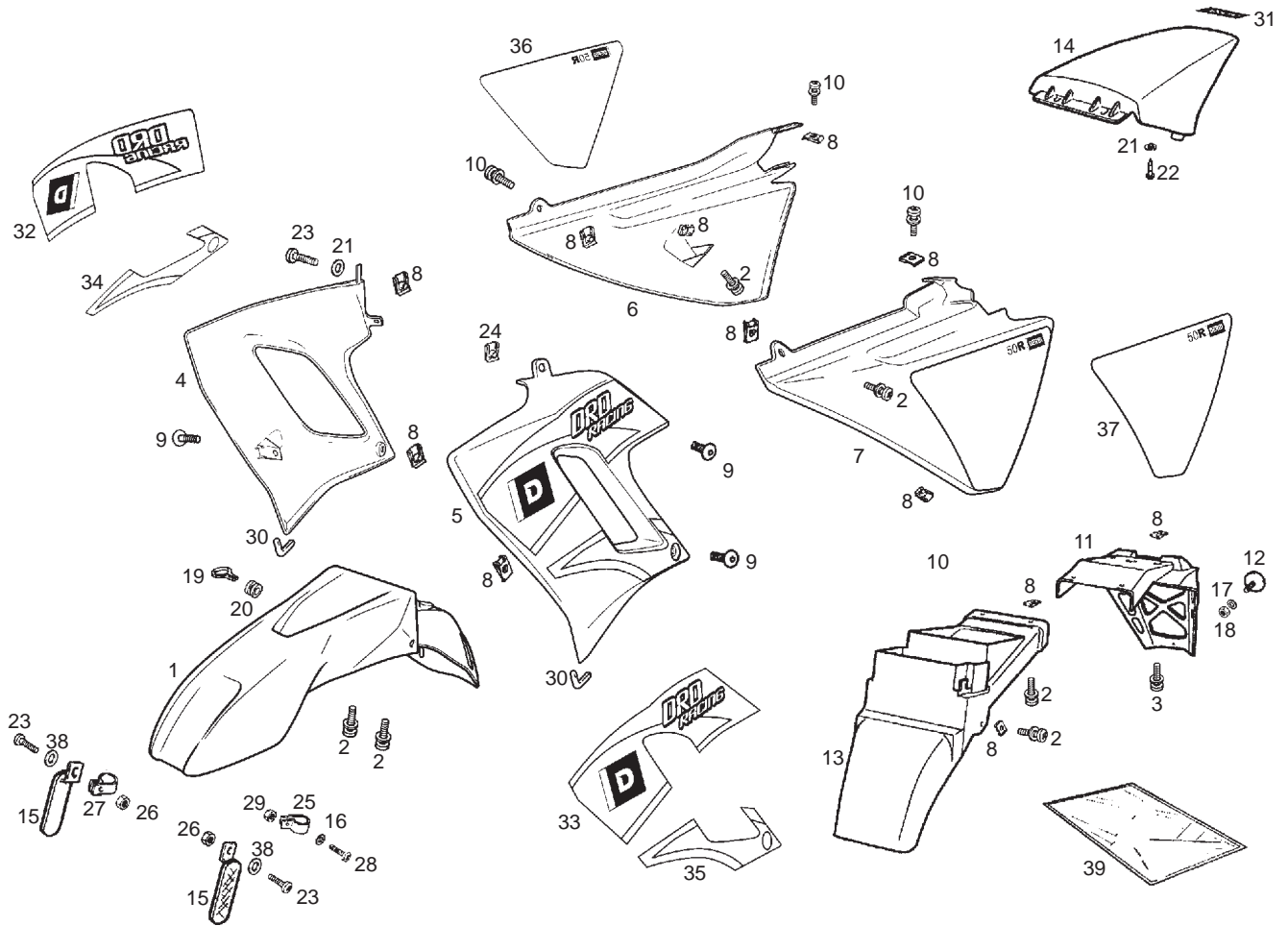

Fig.	Ver.	COD. KOD.	DESCRIPCIÓN DENOMINAZIONE NAME	BEZEICHNUNG DESIGNATION	MOD.	NOTAS NOTES NOTA MITSCHRIFT NOTES
08A		00D01501371	TUERCA FIJ. CUBRECADENA DADO NUT	MUTTER ECROU	1 2 3 4	
09A		00H01501701	TORNILLO FIJ.ESC.FRONTAL VITE SCREW	SCHRAUBE VIS	1 2 3 4	
10A		00F05900041	SCTO.TORNILLO 6M100X16 VITE SCREW	SCHRAUBE VIS	1 2 3 4	
11A		00H00718341	SUPLEM.GUARD.TR. SUPPLEMENTO PARAFANGO POST. SUPPLEM. REAR FENDER	ZUBEHOR STAUBFANGER HINTEN SUPL. GARDE BOUE AR.	1 2 3 4	
12A		00K05110651	CAPTAFAROS TRAS.ROJO CATARIFRANGENTE POSTERIORE R REAR REFLECTOR	RUCKS TRAHLER CATADIOPTRE ARRIERE	1 2 3 4	
13A		00H00705121	GUARDABARROS TR. PARAFANGO POSTERIORE REAR MUDGUARD	KOTFLUGEL HINTEN GARDE BOUE ARRIERE	1 2 3 4	
14A		00H00620161	COLIN COLIN SELLINO SEAT BASE	KOTFLUGEL HINTEN DOSSERET SELLE	1 2 3 4	
15A		00H01802081	CAPTAFAROS CATARIFRANGENTE REFLECTOR	TRAHLER ADHESIF	1 2 3 4	
16A		00402060001	ARANDELA M6 RONDELLA WASHER	SCHEIBE RONDELLE	1 2 3 4	
17A		00000031040	ARANDELA D4 RONDELLA WASHER	SCHEIBE RONDELLE	1 2 3 4	

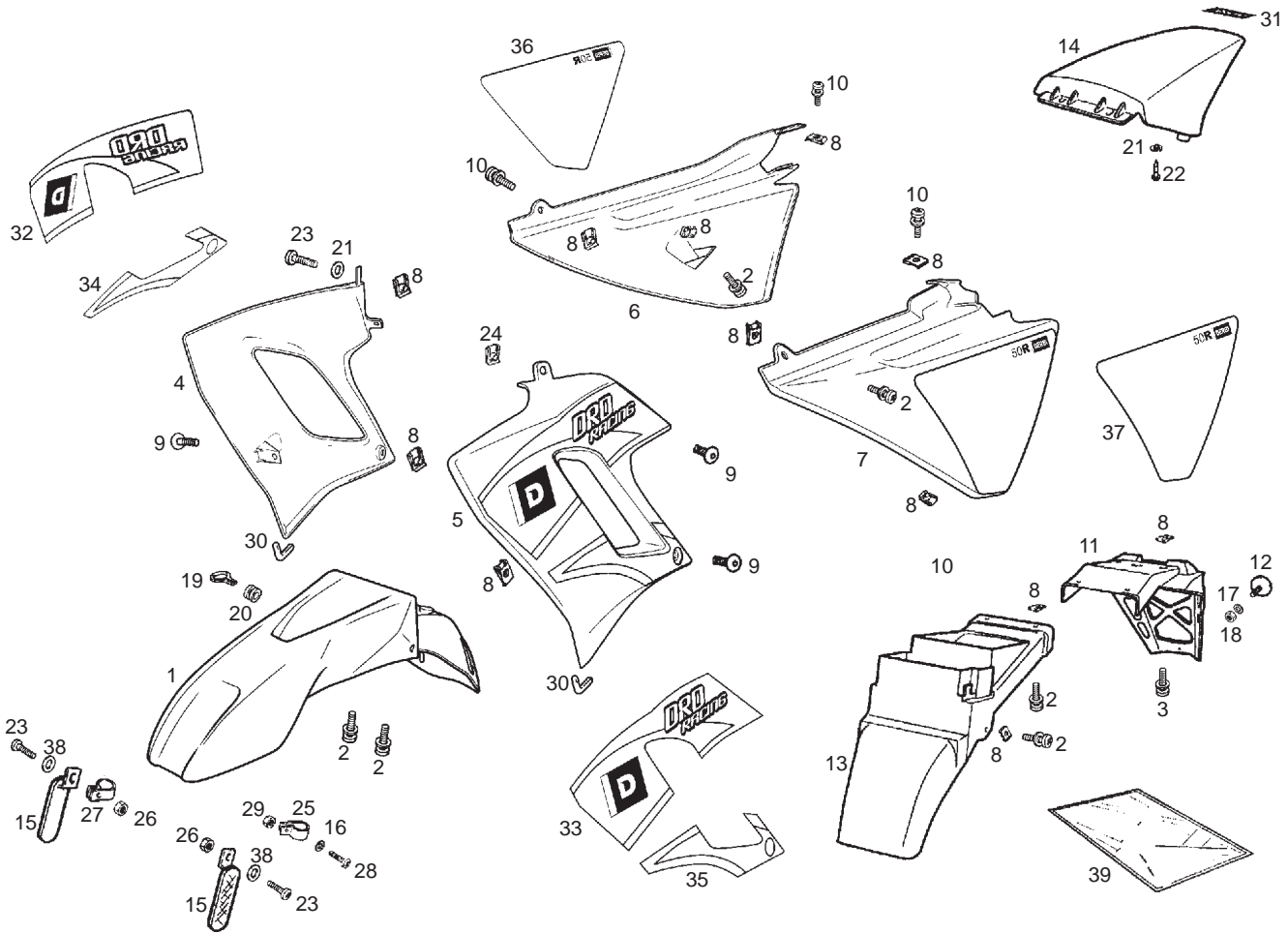

Fig.	Ver.	COD. KOD.	DESCRIPCIÓN DENOMINAZIONE NAME	BEZEICHNUNG DESIGNATION	MOD.	NOTAS NOTES NOTA MITSCHRIFT NOTES
18A		00000021040	TUERCA D4 DADO NUT	MUTTER ECROU	1 2 3 4	
19A		00H02201591	GUIA CABLES FRENO GUIDA CAVI CABLE GUIAE	HALTER F. BEF. BREMSSCHLAU SOUS-EN.SUP.FIX.TUYAU FREIN	1 2 3 4	
20A		00D01500021	PASACABLE PORTACAVI GROMMET	GUMMI PASSE-CABLE	1 2 3 4	
21A		00000031050	ARANDELA D5 RONDELLA WASHER	SCHEIBE RONDELLE	1 2 3 4	
22A		00011051401	TORNILLO AUTRRCTE. 5 X14 VITE SCREW	SCHRAUBE VIS	1 2 3 4	
23A		00012152000	TORNILLO 5M80X20 VITE SCREW	SCHRAUBE VIS	1 2 3 4	
24A		00G04401462	TUERCA FIJACION D5 DADO NUT	MUTTER ECROU	1 2 3 4	
25A		00H02200591	BRIDA BRIGLIA BRIDLE	ZÜGEL BRIDE	1 2 3 4	
26A		00000023051	TUERCA AUTOBLOCANTE 5M80 DADO NUT	MUTTER ECROU	1 2 3 4	
27A		00H01501811	BRIDA BRIGLIA BRIDLE	ZÜGEL BRIDE	1 2 3 4	

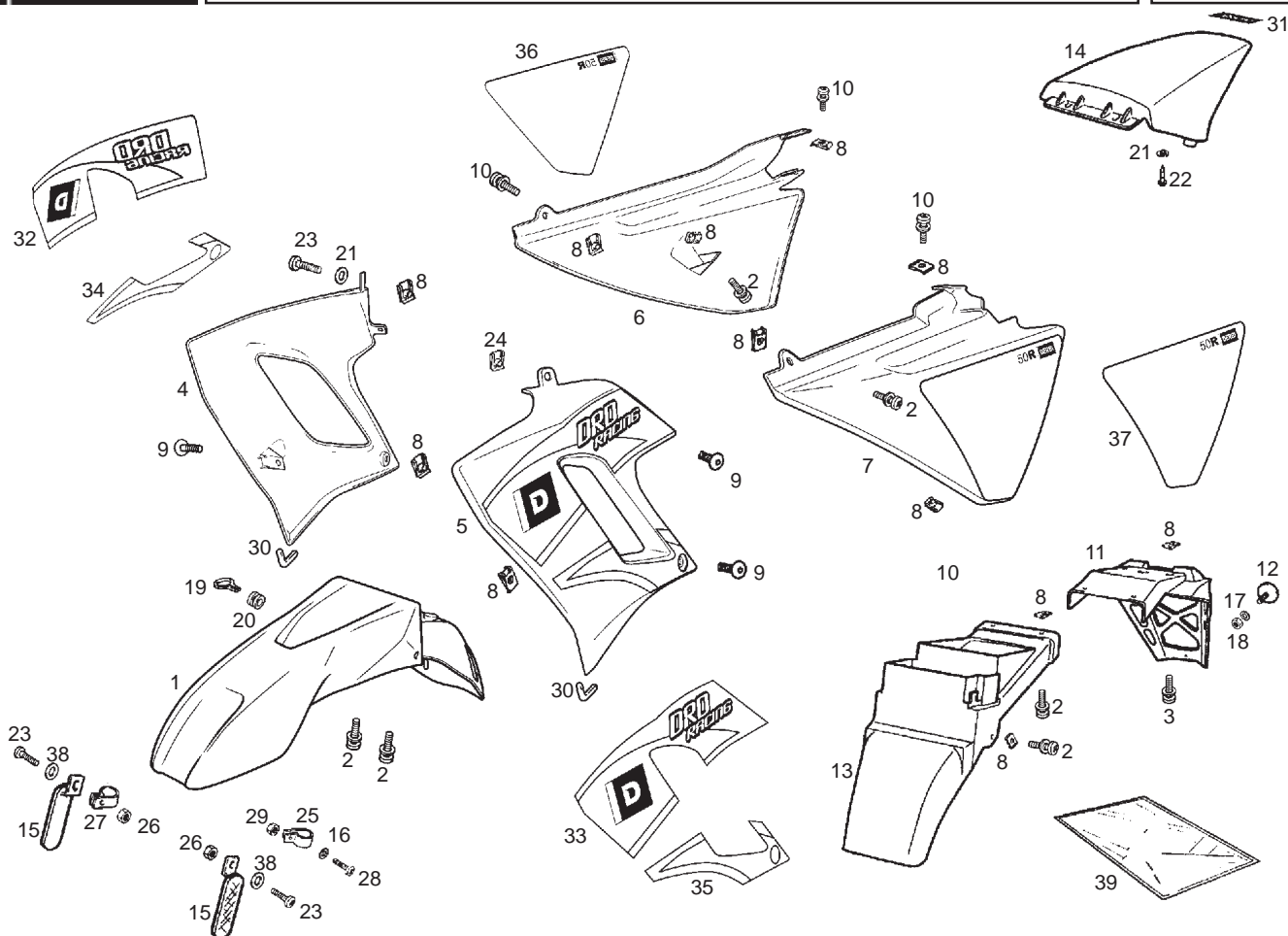

Fig.	Ver.	COD. KOD.	DESCRIPCIÓN DENOMINAZIONE NAME	BEZEICHNUNG DESIGNATION	MOD.	NOTAS NOTES NOTA MITSCHRIFT NOTES
28A		00002062511	TORNILLO C/ALLEN 6M100X25 VITE SCREW	SCHRAUBE VIS	1 2 3 4	
29A		00000023060	TUERCA AUTOBLOC. 6M100 DADO NUT	MUTTER ECROU	1 2 3 4	
30A		00H00502901	PERFIL TAPA DT.DR.DRD RACING PROTEZIONE RUBBER PROTECTOR	GUMMI PROTECTEUR	1 2 3 4	
31A		00H00611521	CALCA DERBI ADESIVO DERBI DECAL DERBI	SCHRIFTZUG DERBI ADHESIF DERBI	1 2 3 4	
32A		00H04926561	CALCA TAPA DELANTERA DERECHA ADESIVO DECAL	SCHRIFTZUG ADHESIF	1 2	
32B		00H04926562	CALCA TAPA DELANTERA DERECHA ADESIVO DECAL	SCHRIFTZUG ADHESIF	3 4	
33A		00H04926571	CALCA TAPA DELANTERA IZQUIERDA ADESIVO DECAL	SCHRIFTZUG ADHESIF	1 2	
33B		00H04926572	CALCA TAPA DELANTERA IZQUIERDA ADESIVO DECAL	SCHRIFTZUG ADHESIF	3 4	
34A		00H04612091	CALCA TAPA INF. DELANTERA DERECHA ADESIVO DECAL	SCHRIFTZUG ADHESIF	1 2 3 4	
35A		00H04612101	CALCA TAPA INF. DELANTERA IZQUIERDA ADESIVO DECAL	SCHRIFTZUG ADHESIF	1 2 3 4	

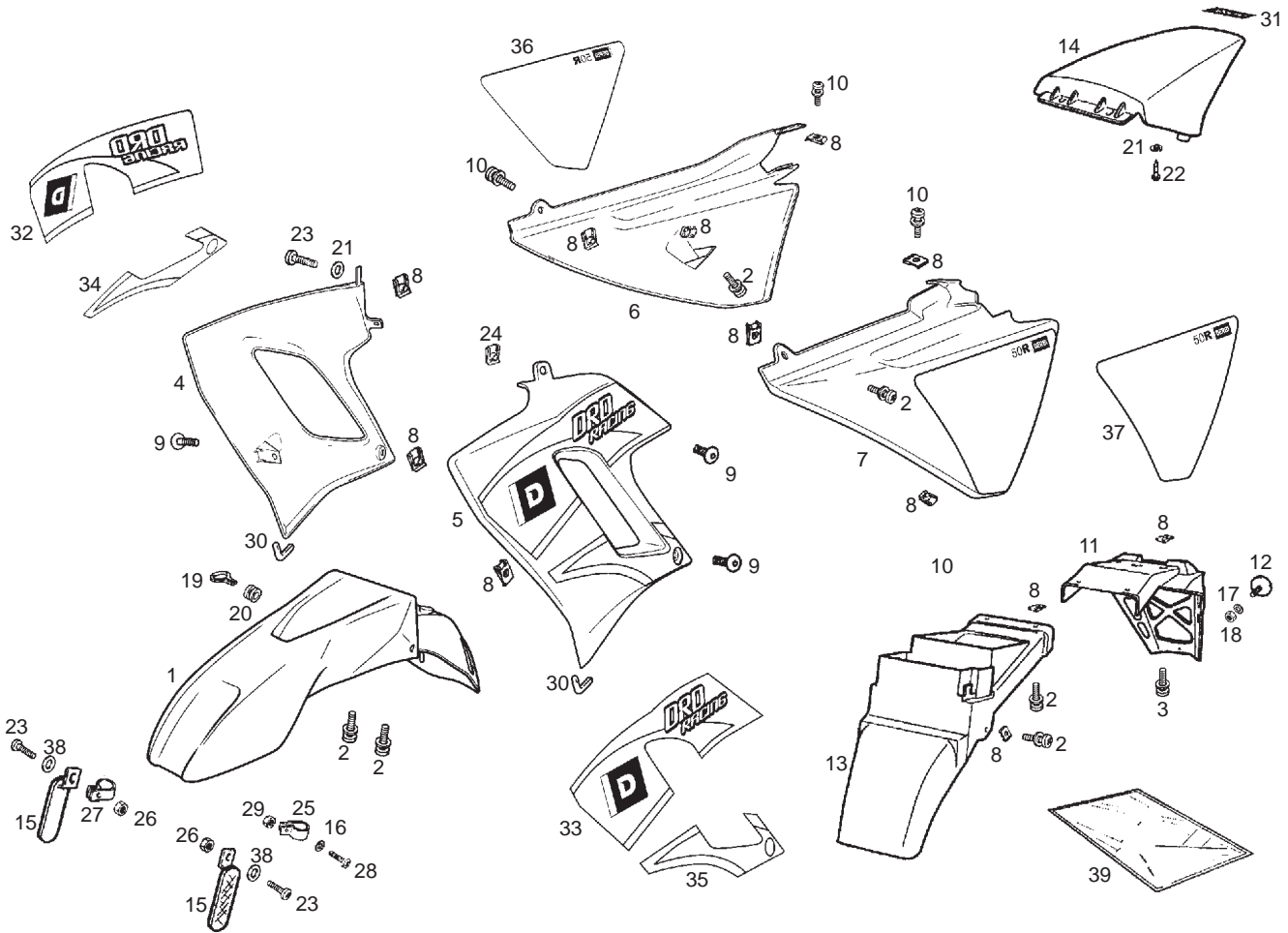

Fig.	Ver.	COD. KOD.	DESCRIPCIÓN DENOMINAZIONE NAME	BEZEICHNUNG DESIGNATION	MOD.	NOTAS NOTES NOTA MITSCHRIFT NOTES
36A		00H00527651	CALCA TAPA LATERAL DERECHA ADESIVO DECAL	SCHRIFTZUG ADHESIF	1 2 3 4	
37A		00H00529641	CALCA TAPA LATERAL IZQUIERDA ADESIVO DECAL	SCHRIFTZUG ADHESIF	1 2 3 4	
38A		00031105000	ARANDELA RONDELLA WASHER	SCHEIBE RONDELLE	1 2 3 4	
39A		00H05160651	R-JUEGO CALCAS SD-R DRD RACING AZ. COMPL.ADESIVI DECALSASSY	AUFKLEBERSATZ JEU ADHESIF	1 2	
39B		00H05160652	R-JUEGO CALCAS SD-R DRD RACING R.J. COMPL.ADESIVI DECALSASSY	AUFKLEBERSATZ JEU ADHESIF	3 4	

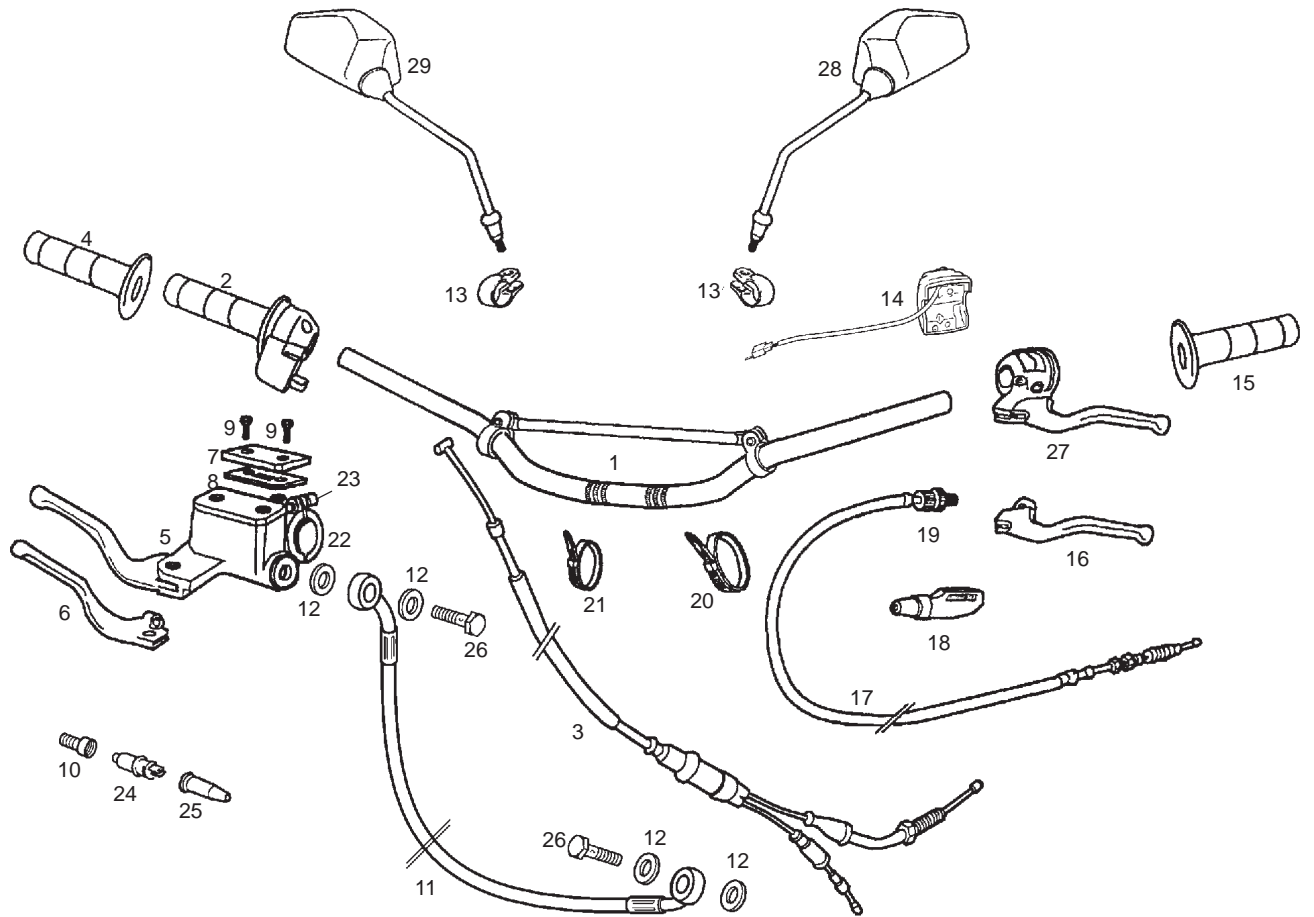

Fig.	Ver.	COD. KOD.	DESCRIPCIÓN DENOMINAZIONE NAME	BEZEICHUNG DESIGNATION	MOD.	NOTAS NOTES NOTA MITSCHRIFT NOTES
01A		00H00906013	SCTO. MANILLAR MANUBRIO HANDLEBAR ASSY	LENKER GUIDON	1 2 3 4	
02A		00H02101621	CTO. PUÑO GAS MANOPOLA ACCELERATOR THROTTLE GRIP ASSEMBLY	GASGRIF POIGNEE DE GAZ COMPLETE	1 2 3 4	
03A		00H00916171	SCTO. CABLE FUNDA GAS CAVO-FODERO ACCELERA CABLE ASSY TRHOTTLE	GASKABEL GAINE ET CABLE DE GAZ	1 2 3 4	
04A		00H00930091	R-EMPUÑADURA GAS R-MANOPOLA ACCELERATORE V.W.CH GRIP, THROTTLE	GRIFF CAOUT. DE PIGNEE GAZ	1 2 3 4	
05A		00H02105082	R-CTO. MANDO FRENO DTRO. R-COMANDO FRENO FRONT BRAKE LEVER/MASTER CYLIN	REP.-SATZ F. PUMPE R-ENSEM. KIT REPAR. POMPE SE	1 2 3 4	
06A		00H00906203	R-MANETA FRENO TRASERO MANOPOLA FRENO BRAKE LEVER	BREMSHEBEL KOMPL. MANETE DU FREIN AVANT	1 2 3 4	
07A		00H02100191	R-TAPA DEPOSITO LIQ. FRENO DT. COPERCHIO SERBATOIO LIQUIDO BRAKE FLUID RESERVOIR CAP	BREMSFLUESSIGKEITSBEHAELTE R-COUV. RESER. LIQ. FREIN AVAN	1 2 3 4	
08A		00H02100861	R-JUNTA TAPA DEP. LIQ. FRENO GUARNIZIONE COPERCHIO BRAKE FLUID RESERVOIR CAP SEAL	BREMSCECKELDICHUNG R-JOINT COUV. RES. LIQ. FR. AV.	1 2 3 4	
09A		00014041200	TORNILLO C/AR. CRUZ NG. 4 M 80 X 12 VITE SCREW	SCHRAUBE VIS	1 2 3 4	
10A		00H00900871	CASQUILLO FIJ. INTERRUPTOR STOP BRONZINA BUSHING	BUCHSE ENTRETOISE	1 2 3 4	
11A		00H00919751	SCTO. TUBO LIQUIDO FRENO DT SUBCOMP. TUBO LIQ. FRE. BRAKE FLUID TUBE	BREMSSSCHLAUCH FLEXIBLE DE FREIN AVANT	1 2 3 4	

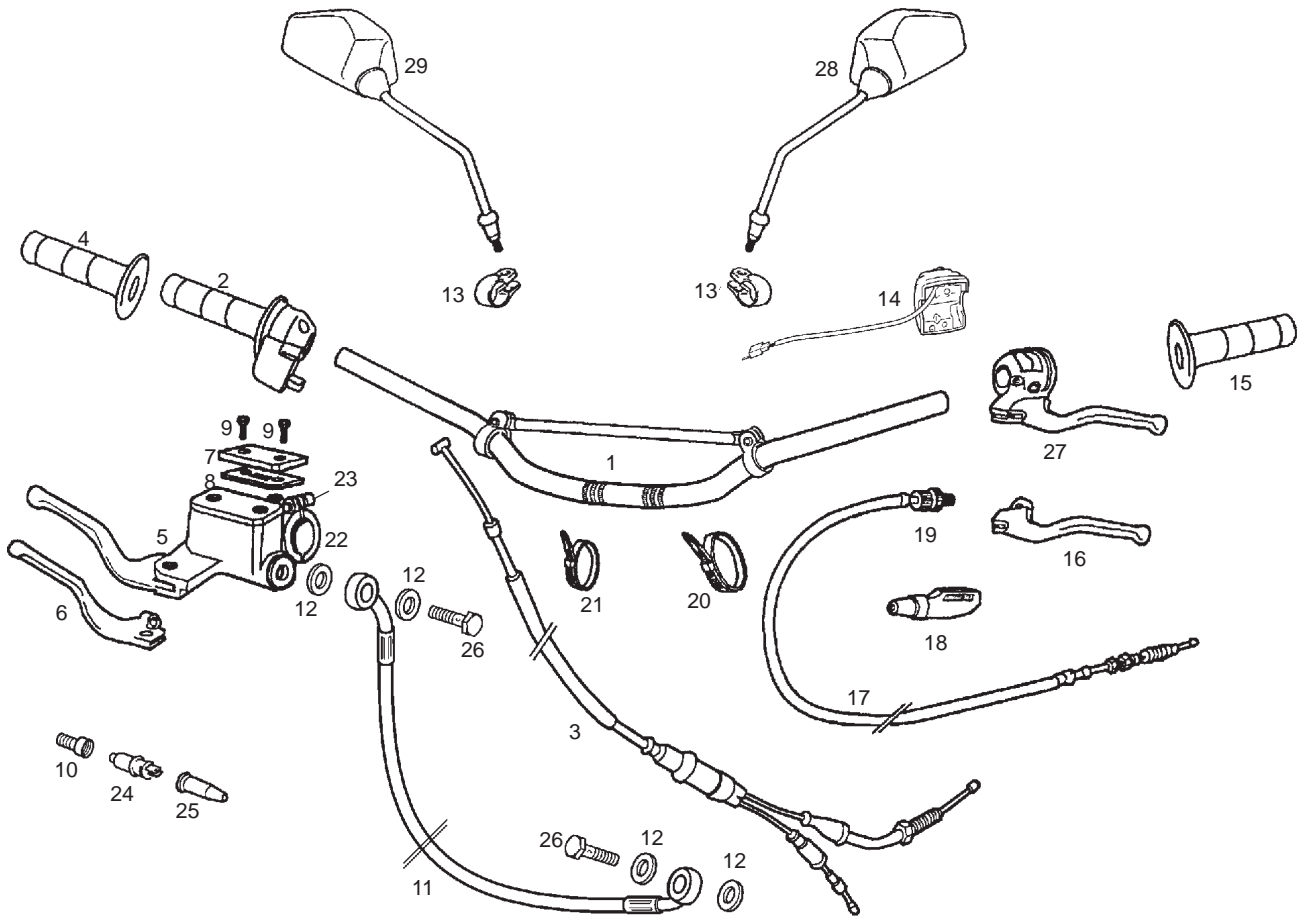

Fig.	Ver.	COD. KOD.	DESCRIPCIÓN DENOMINAZIONE NAME	BEZEICHNUNG DESIGNATION	MOD.	NOTAS NOTES NOTA MITSCHRIFT NOTES
12A		00006321040	ARANDELA JUNTA RACORD RONDELLA WASHER	SCHEIBE RONDELLE	1 2 3 4	
13A		00H02200681	BRIDA BRIGLIA BRIDLE	ZÜGEL BRIDE	1 2 3 4	
14A		00H02304381	CTO. CONMUTADOR LUCES C/C CONMUTATORE LUCI SWITCH	LICHTSCHALTER INVERSEUR AVEC CABLE	1 2	UNTIL FRAME 4H266742
14B		00H02305381	CTO. CONMUTADOR LUCES C/C CONMUTATORE LUCI SWITCH	LICHTSCHALTER INVERSEUR AVEC CABLE	1 2 3 4	SINCE FRAME 4H266742
15A		00H00930071	R-EMPUÑADURA PUÑO LUZ R-MANOPOLA FRENO POSTERIORE 13 GRIP, THROTTLE	GRIFF CAOUT.DE PIGNEE GAZ	1 2 3 4	
16A		00H00903291	R-MAN. EMBR. LEVIER EMBRAYAGE CLUTCH LEVER	KUPPLUNGSHEBEL LEVIER EMBRAYAGE	1 2 3 4	
17A		00H00907301	SCTO.CABLE-FUNDA EMBRG. CAVO-GUAINA FRIZ. CLUTCH COVER AND CAB.SUB.ASSY.	KUPPLUNGSZUG GAINE ET CABLE DIEMBAYAGE	1 2 3 4	
18A		00H02101011	PROTECTOR MANETA EMBRAGUE PROTETTORE LEVA FRIZIONE SD-CLUTCH LEVER PROTECTOR	GUMMIKAPPE PROTEGE LEVIER EMBRAY.	1 2 3 4	
19A		00F00920551	R-CTO TENSOR CABLE EMBRAGUE TENSORE CABO CLUTCH CABLE TIGHTENING DEVIC	SHELLE COLLIER FIX ELIERIE	1 2 3 4	
20A		00F00900531	BRIDA BRIGLIA BRIDLE	ZÜGEL BRIDE	1 2 3 4	
21A		00A00900531	BRIDA BRIGLIA BRIDLE	ZÜGEL BRIDE	1 2 3 4	

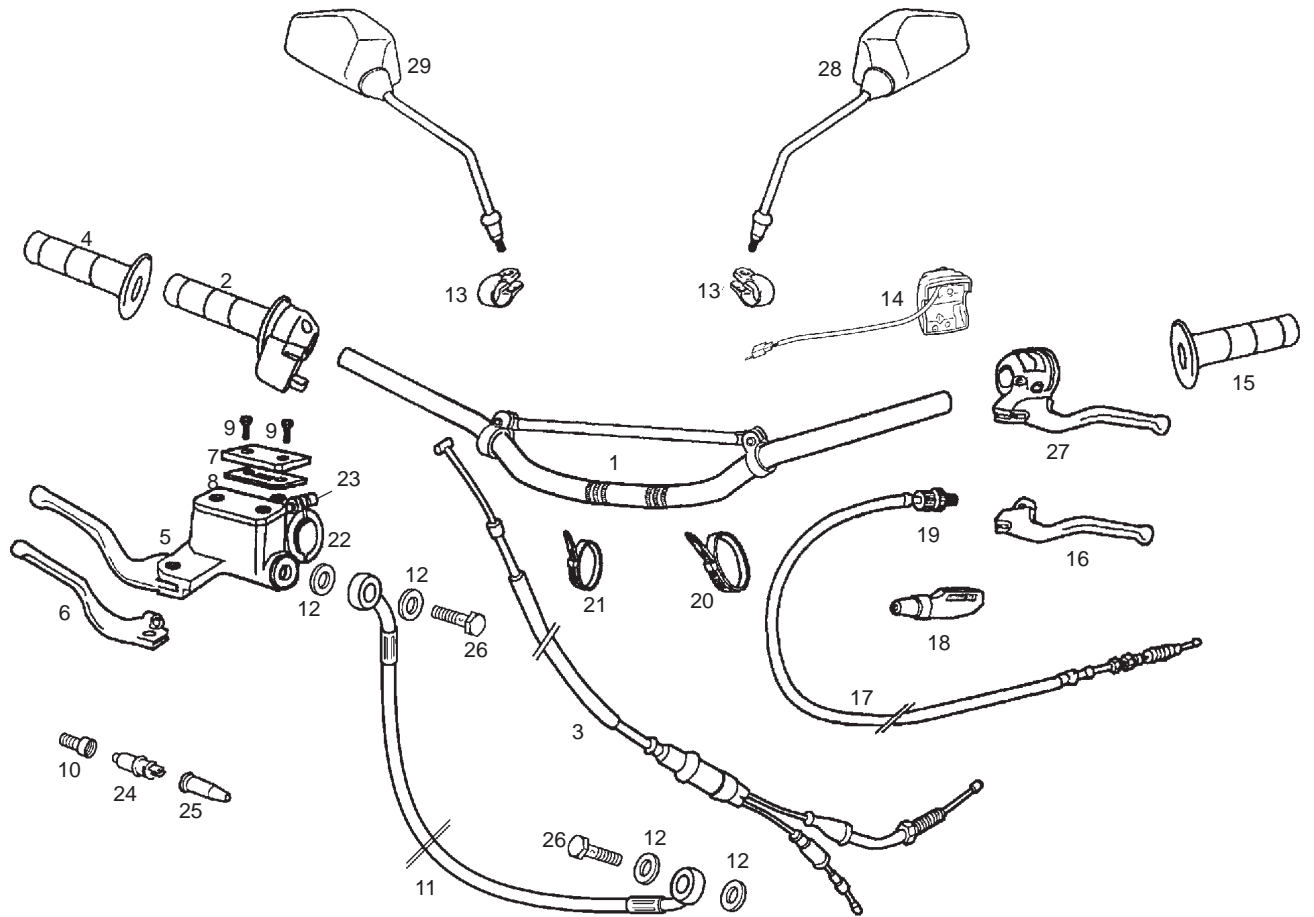

Fig.	Ver.	COD. KOD.	DESCRIPCIÓN DENOMINAZIONE NAME	BEZEICHUNG DESIGNATION	MOD.	NOTAS NOTES NOTA MITSCHRIFT NOTES
22A		00H02100901	R-BRIDA FIJACION MANDO FRENO DT CAVALLOTO FISSAGIO POMPA CLAMP	BEF.-SCHELLE ENTRETOISE	1 2 3 4	
23A		00002051251	TORNILLO FIJACION BRIDA 5M80X12 VITE SCREW	SCHRAUBE VIS	1 2 3 4	
24A		00D01000701	INTERRUP.MANDO STOP. INTERRUPTORE STOP SWITCH, STOP LIGHT	STOPCHALTER VO. INTERRUPTEUR COMMANDE STOP	1 2 3 4	
25A		00005010760	CAPUCH.INTERRUP.STOP.NG. CAPPuccio INTERRUPTORE STOP NE RUBBER COVER, STOP LIGHT SWITCH	GUMMISCHUTZ STOPLICHTSCHAL CAPUCHON	1 2 3 4	
26A		00006309260	RACORD TUBO HIDRAULICO RACCORDO TUBO IDRAULICO HYDRAULIC TUBE CONNECTOR	STUTZEN HIDRAULIKLEITUNG RACCORD TUYAU HYDRAULIQUE	1 2 3 4	
27A		00H02105612	CTO. PORTAM. IZQ. PORTAMANOPOLA SINIST LEFT LEVER BRACKET	BREMSHEBEL LINKS KOMPLETT ENS. PORTE-MANETTE GAUCHE	1 2 3 4	
28A		00G04613921	CTO. ESPEJO RETROVISOR SPECCHIETO RETROVISO REAR MIRROR	SPIEGEL MIRROIR RETROVISEUR	1 2 3 4	
29A		00H02207671	CTO. ESPEJO RETROVISOR SPECCHIETO RETROVISO REAR MIRROR	SPIEGEL MIRROIR RETROVISEUR	1 2 3 4	



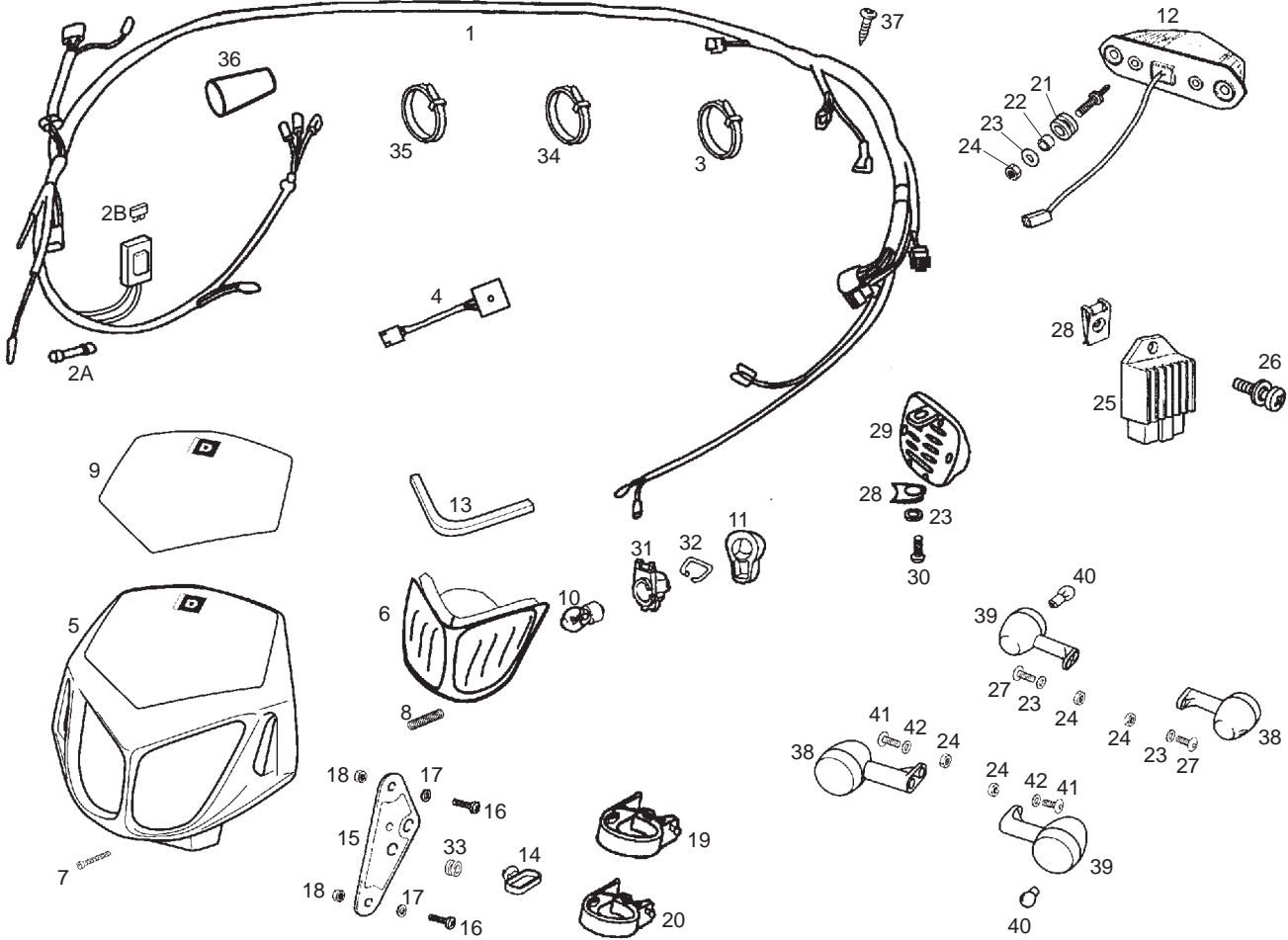

Fig.	Ver.	COD. KOD.	DESCRIPCIÓN DENOMINAZIONE NAME	BEZEICHNUNG DESIGNATION	MOD.	NOTAS NOTES NOTA MITSCHRIFT NOTES
01A		00H01038301	CTO. INSTALACION ELECTRICA COMPLESSO IMPIANTO ELETRICO ELECTRICAL INSTALATIONS ASSY.	KOBELBAUM FAISCEAU ELECTRIQUE	1 2	UNTIL FRAME 4H266742
01B		00H01047301	CTO. INSTALACION ELECTRICA COMPLESSO IMPIANTO ELETRICO ELECTRICAL INSTALATIONS ASSY.	KOBELBAUM FAISCEAU ELECTRIQUE	1 2 3 4	SINCE FRAME 4H266742
02A		00G01000911	FUSIBLE 4 AMP FUSIBILE FUSE	FUSE FUSIBLE	1 2	
02B		00H01001911	FUSIBLE 7,5 AMP FUSIBILE FUSE	FUSE FUSIBLE	1 2 3 4	
03A		00D00900531	BRIDA BRIGLIA BRIDLE	ZÜGEL BRIDE	1 2 3 4	
04A		00H05700481	CTO. TEMPORIZADOR CHECK TEMPORIZZATORE CHECK INP. TIMER CHECK INDICATOR	ZEITSCHALTER FAISCEAU COMPTEUR	1 2 3 4	
05A		00H02239371	SCTO.CARC.FARO NEGRA SUBCOMP.CARC.FARO C/C. HEADLIGHT CUSING SUB-ASSEMBLY	SCHEINWERFERVERKLEIDUNG PLAQUE PHARE	1 2 3 4	
06A		00H01013011	CTO. FARO DT SENDA COMPLESSO FARO ANTERIORE HEADLIGHT LENS SUB-ASSEMBLY	SCHEINWERFER OPTIQUE COMPLETE	1 2 3 4	
07A		00012045000	TORNILLO REGULACION FARO VITE SCREW	SCHRAUBE VIS	1 2 3 4	
08A		00H02304501	MUELLE REGULACION FARO MOLLA SPRING	FEDER RESSORT	1 2 3 4	
09A		00H01533321	CALCA CARCASA ADESIVO PLACCA FRONTALE FORNT PLATE DECAL	CAUFKLEVER DECAL DE PLAQUE PHARE	1 2 3 4	

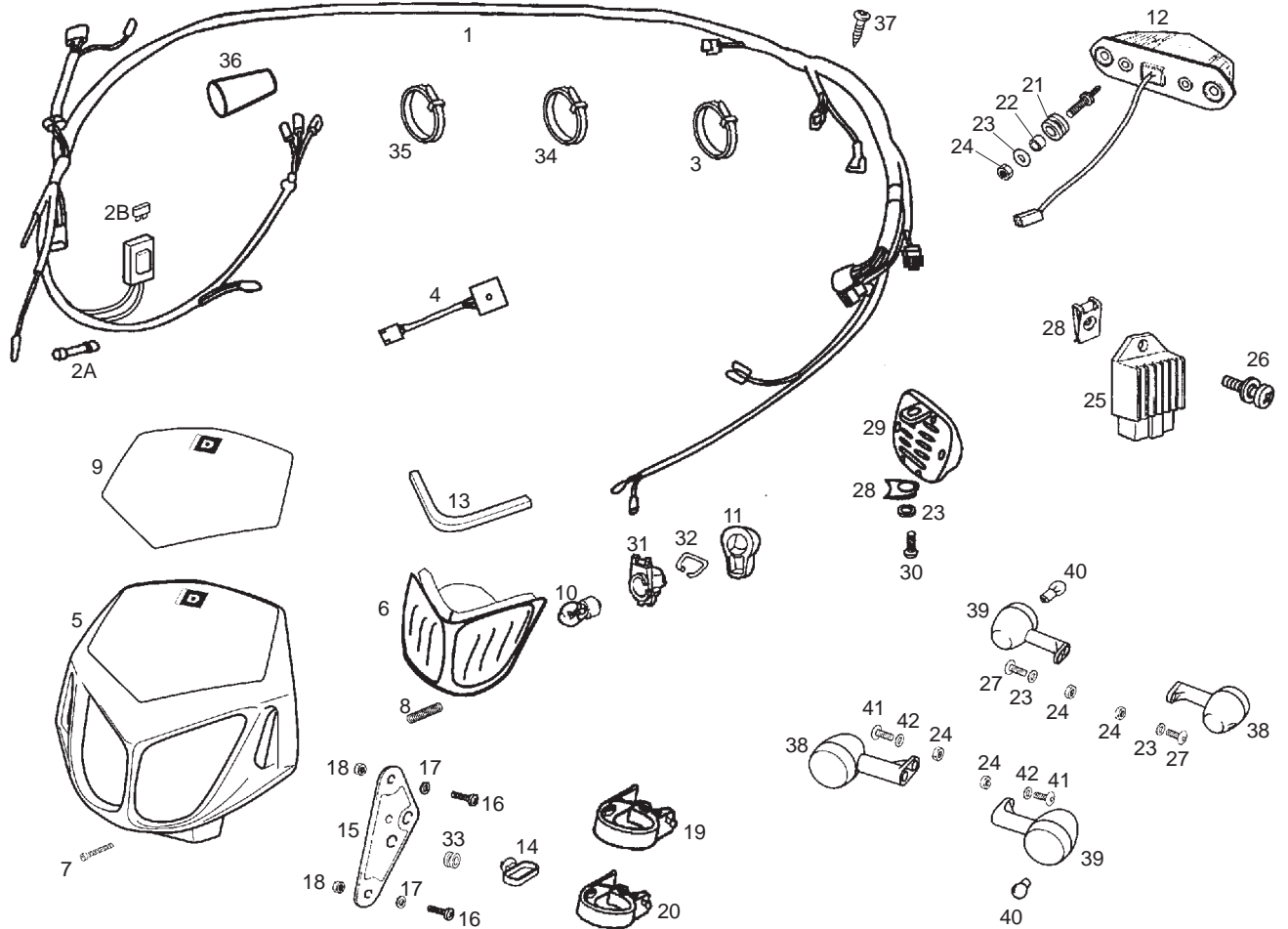

Fig.	Ver.	COD. KOD.	DESCRIPCIÓN DENOMINAZIONE NAME	BEZEICHNUNG DESIGNATION	MOD.	NOTAS NOTES NOTA MITSCHRIFT NOTES
10A		00H01000131	LAMPARA FARO. 12V.35/35W. LAMPADA FARO 12V 35/35W HEADLIGHT BULB	SCHEINWERFERLAMPE 12V/35-3 TUBE PHARE 12V/35-35W	1 2 3 4	
11A		00D05700141	R-PROTECT.PORTALAMP.FARO FDS-SV R-PROTEZIONE PORTA LAMPADA FA HEADLAMP BULB HOLDER PROTC	LAMPENDECKEL R-PROT.PORTE-LAMPES PHARE F	1 2 3 4	
12A		00H01009321	CTO.FARO PILOTO COMPLESSO FANALINO POSTERIORE TAIL LIGHT ASSY	RUCKLIGHT FEU ARRIERE	1 2 3 4	
13A		00H05700101	TOPE FARO FERMO FARO HEADLIGHT STOP	ANSCHLAG SCHEINWERFER BUTEE PHARE	1 2 3 4	
14A		00F02201591	GUIA CABLES GUIDA CAVI CABLE GUIAE	HALTER F. BEF. FIX.TUYAU	1 2 3 4	
15A		00H01503741	SOPORTE CARCASA FARO SUPPORTO CARC. HEADLIGHT CUSING SUPPORT	HALTERUNG SUPPORT	1 2 3 4	
16A		00012051200	TORNILLO VITE SCREW	SCHRAUBE VIS	1 2 3 4	
17A		00D02600631	ARANDELA RONDELLA WASHER	SCHEIBE RONDELLE	1 2 3 4	
18A		00026005000	TUERCA DADO NUT	MUTTER ECROU	1 2 3 4	
19A		00H04605841	BRIDA BRIGLIA BRIDLE	ZÜGEL BRIDE	1 2 3 4	
20A		00H04603841	BRIDA BRIGLIA BRIDLE	ZÜGEL BRIDE	1 2 3 4	

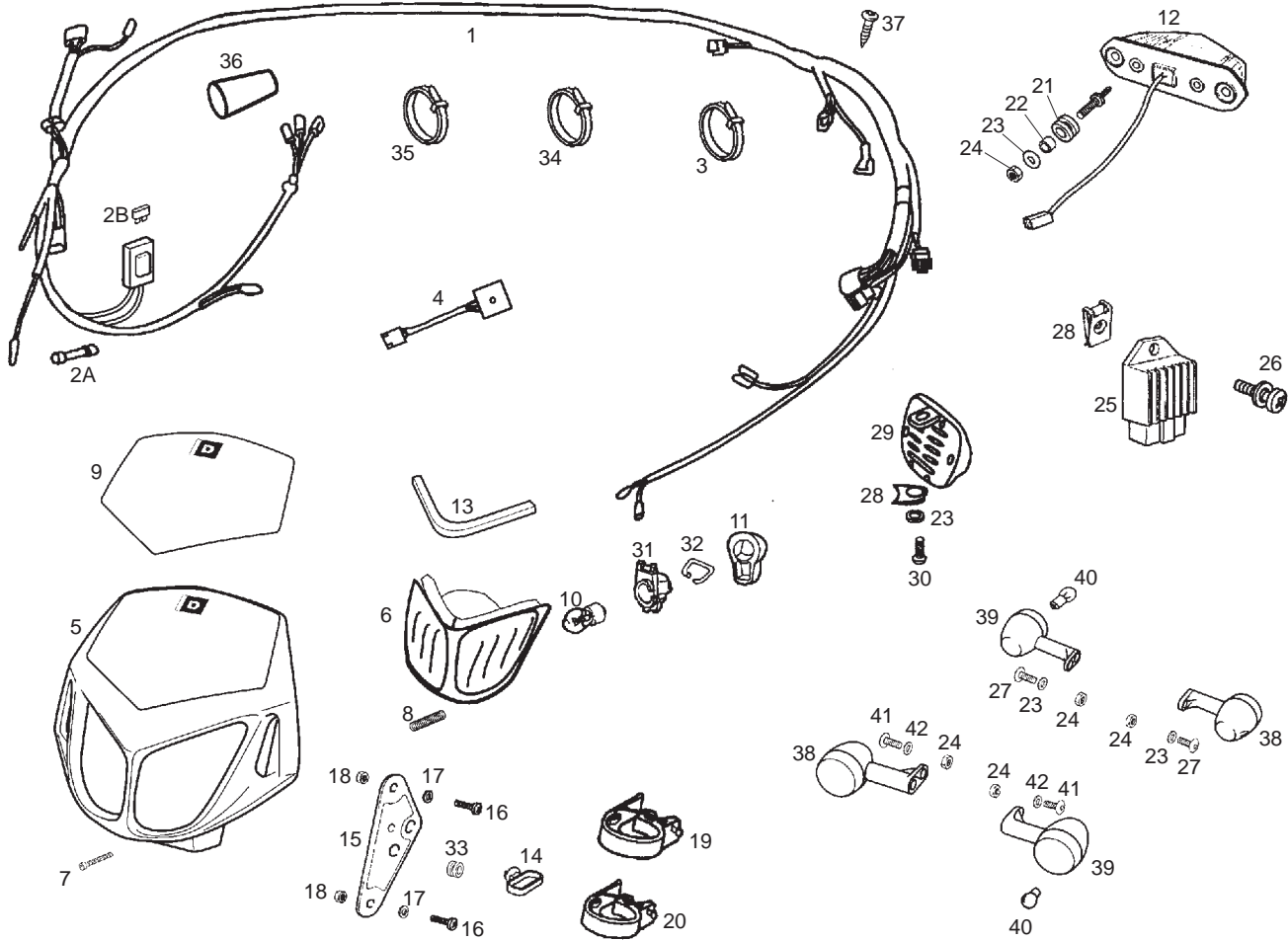

Fig.	Ver.	COD. KOD.	DESCRIPCIÓN DENOMINAZIONE NAME	BEZEICHNUNG DESIGNATION	MOD.	NOTAS NOTES NOTA MITSCHRIFT NOTES
21A		00008915020	PASACABLE PORTACAVI GROMMET	GUMMI PASSE-CABLE	1 2 3 4	
22A		00D01500471	CASQUILLO BRONZINA BUSHING	BUCHSE ENTRETOISE	1 2 3 4	
23A		00D01200171	ARANDELA EJE LEVA-FIJ.CUBRECAD. RONDELLA WASHER	SCHEIBE RONDELLE	1 2 3 4	
24A		00000023060	TUERCAAUTOBLOC. 6M125 DADO NUT	MUTTER ECROU	1 2 3 4	
25A		00H01007841	REGULADOR REGULATORE TENSIONE REGULATOR	SPANNUNGSREGLER REGULATEUR AC/DC	1 2 3 4	
26A		00F05900041	SCTO.TORNILLO 6M100X16 VITE SCREW	SCHRAUBE VIS	1 2 3 4	
27A		00008061500	TORNILLO C/RED.ALLEN 6M100X16 VITE SCREW	SCHRAUBE VIS	1 2 3 4	
28A		00D01501371	TUERCA FIJ. CUBRECADENA DADO NUT	MUTTER ECROU	1 2 3 4	
29A		00H01005311	CTO.CLAXON.12V-DC/0450-A.SC/91 CLACSON 12V CC HORN ASSEMBLY	HUPE 12V-DC/ D450-A.SC/91 KLAXON COMPLET 12V.DC/0450-	1 2 3 4	
30A		00012061200	TORNILLO C/R.CR.6M100X12.NG VITE SCREW	SCHRAUBE VIS	1 2 3 4	
31A		00003710110	R-PORTALAMPARAS PORTA-LAMPADE BULB HOLDER	LAMPENHALTER R-PORTE-LAMPES	1 2 3 4	

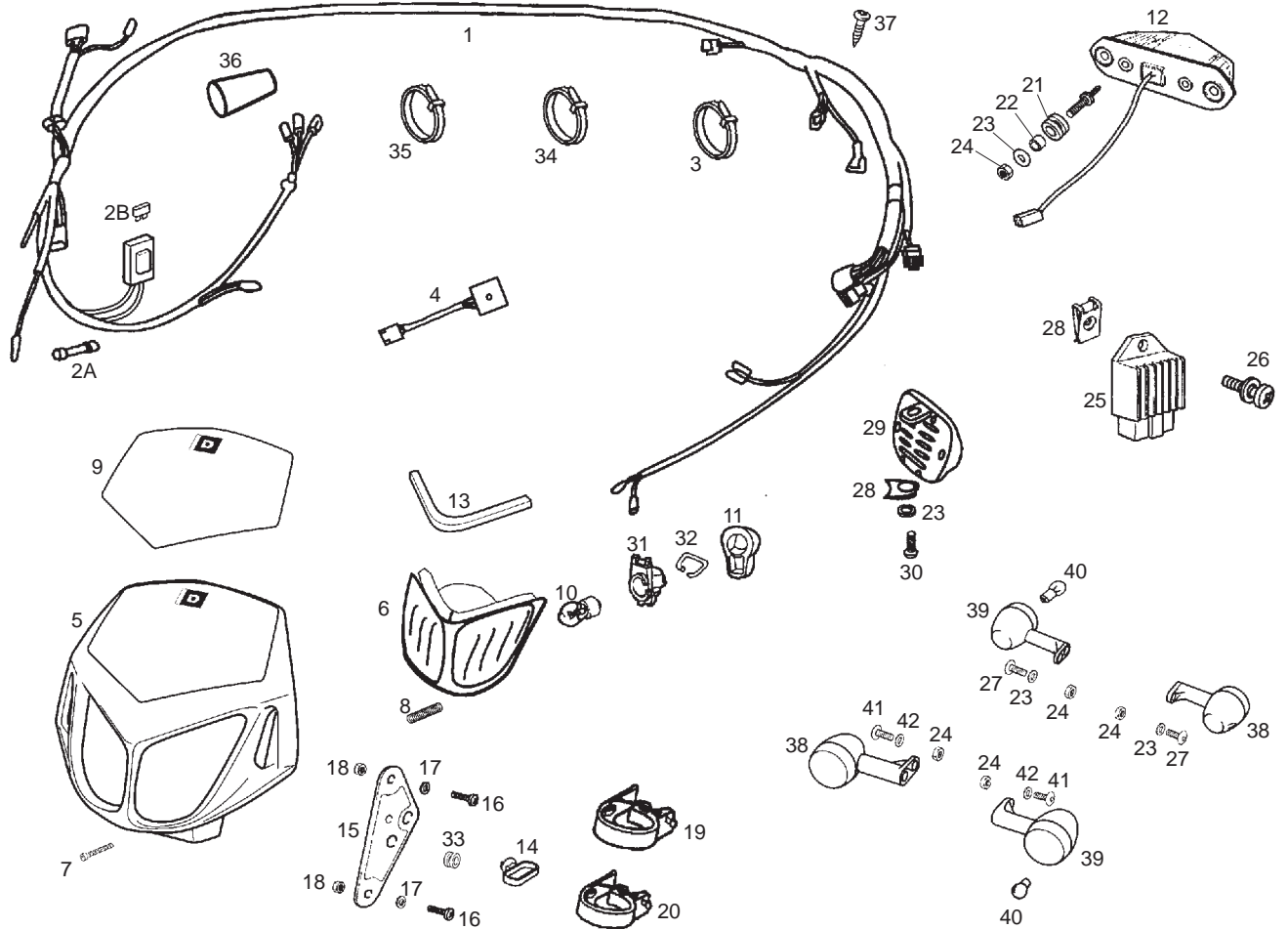

Fig.	Ver.	COD. KOD.	DESCRIPCIÓN DENOMINAZIONE NAME	BEZEICHUNG DESIGNATION	MOD.	NOTAS NOTES NOTA MITSCHRIFT NOTES
32A		00003710120	R-MUELLE PORTLAMPARAS R- MOLLA PORTALAMPADE BULB HOLDER SPRING	FEDER F. LAMPENHALTER R-RESSORT PORTE-LAMPES	1 2 3 4	
33A		00H05701061	PASACABLE PORTACAVI GROMMET	GUMMI PASSE-CABLE	1 2 3 4	
34A		00F00900531	BRIDA BRIGLIA BRIDLE	ZÜGEL BRIDE	1 2 3 4	
35A		00A00900531	BRIDA BRIGLIA BRIDLE	ZÜGEL BRIDE	1 2 3 4	
36A		00H02300961	PROTECTOR CONEXIONES PROTEZIONE PROTECTOR	ABDECKUNG PROTECTEUR	1 2 3 4	
37A		00011061300	TORNILLO AUTR.C/CRUZ.6,3X13 VITE SCREW	SCHRAUBE VIS	1 2 3 4	
38A		00H01704311	CTO.FARO INTTE. DELANTERO DERECHO INDIC. DIREZIONE FRONT RH TURN SIGNAL LIGHT	BLINKER CLIGNOTANTS	1 2 3 4	
39A		00H01706021	CTO.FARO INTTE. DELANTERO IZQUIERDO INDIC. DIREZIONE FRONT LH TURN SIGNAL LIGHT	BLINKER CLIGNOTANTS	1 2 3 4	
40A		00H01701011	LAMPARA LAMPADA BULB	LAMPE TUBE PHARE	1 2 3 4	
41A		00008063000	TORNILLO C/RED.ALLEN 6M100X30 VITE SCREW	SCHRAUBE VIS	1 2 3 4	
42A		00031106000	ARANDELA PLANA D6 RONDELLA WASHER	SCHEIBE RONDELLE	1 2 3 4	

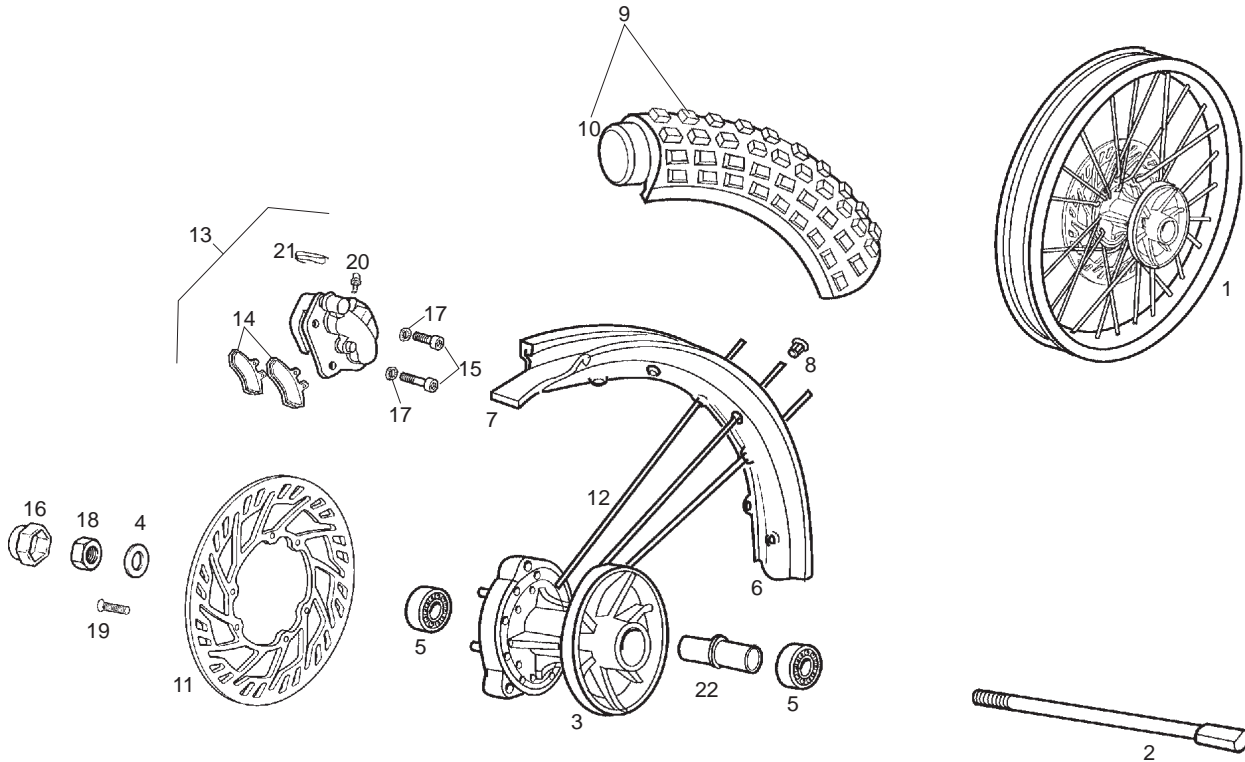

Fig.	Ver.	COD. KOD.	DESCRIPCIÓN DENOMINAZIONE NAME	BEZEICHNUNG DESIGNATION	MOD.	NOTAS NOTES NOTA MITSCHRIFT NOTES
01A		00H04722082	R-CTO. RUEDA DT. R DRD RACING AZUL R-COMPL. RUOTA ANT. C/DISEGNO FRONT WHEEL ASSEMBLY	VORDERRAED ROUE AV. COMPLETE	1 2 3 4	
02A		00H01202271	EJE RUEDA DTRA. ASSE RUOTA ANTERIORE AXLE FRONT WHEEL	VORDERRADACHSE AXE DE ROUE AV.	1 2 3 4	
03A		00H01204714	CTO. CARRETE DT. MOZZO ANT. FRONT HUB ASSY	RADNABE MOYEU	1 2 3 4	
04A		00032015000	ARANDELA PLANA. D.15. RONDELLA WASHER	SCHEIBE RONDELLE	1 2 3 4	
05A		00000056202	COJINETE CUSCINETTO BEARING	LAGER COUSSINET	1 2 3 4	
06A		00H01209083	LLANTA RDA. DT. AZUL CERCHIONE RUOTA ANT. FRONT WHEEL RIM	VORDERRADFELGE JANTE AV.	1 2 3 4	
07A		00D01201091	PROTECT. CAMARA RDA. DTRA.21". SV PROTECTOR CAMERA RUOTA ANT.21 RIM STRIP	FELGELBAND PROTECTOR DE CHAMBRE A AIR	1 2 3 4	
08A		00002212070	TUERCA RAD 10. DADO NUT	MUTTER ECROU	1 2 3 4	
09A		00H01219111	CTO. CUBIERTA DT 90/90-21" COPERTONE TYRE	REIFEN PNEU	1 2 3 4	
10A		00H01206101	CAMARA RDA. DT.21AB CAMERA D'ARIA FRONT TUBE	SCHLAUCH VORNE CHAMBRE A AIR	1 2 3 4	

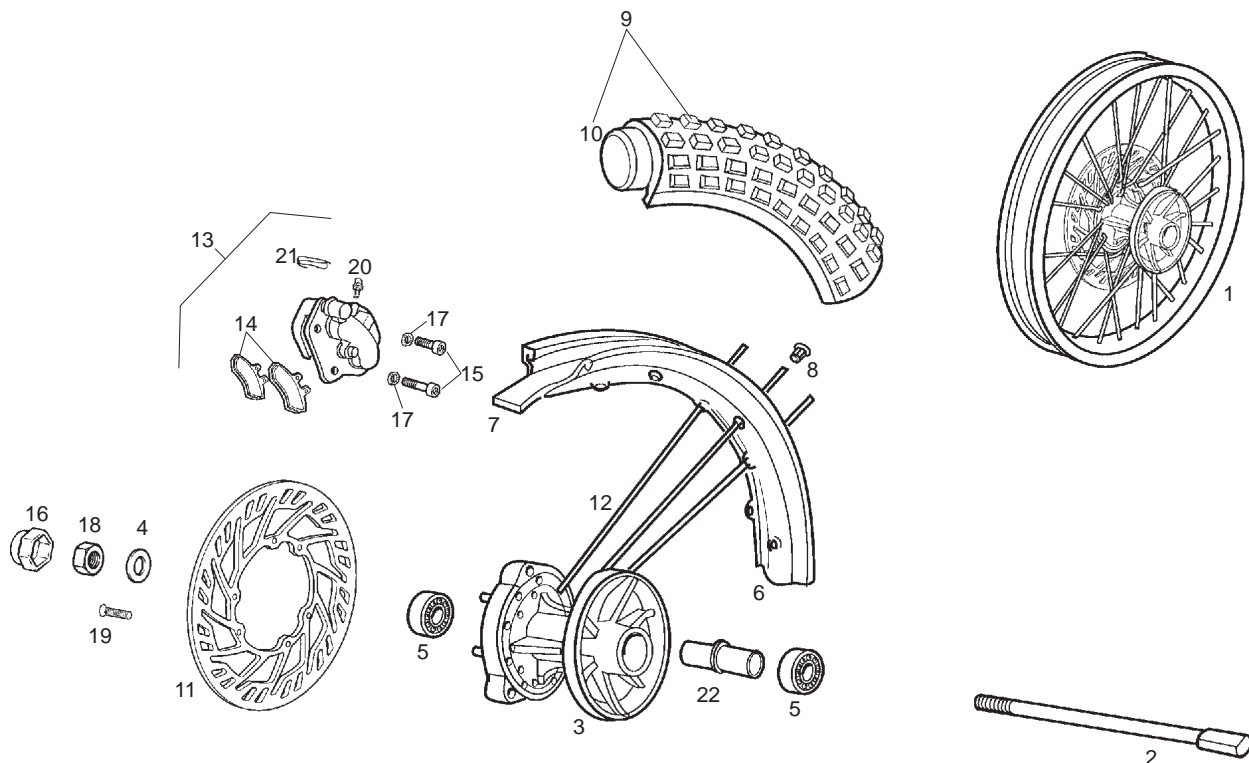

Fig.	Ver.	COD. KOD.	DESCRIPCIÓN DENOMINAZIONE NAME	BEZEICHNUNG DESIGNATION	MOD.	NOTAS NOTES NOTA MITSCHRIFT NOTES
11A		00H01214021	DISCO FR. DT. DISCO FRENO ANTERIORE FRONT BRAKE DISC	SCHEIBE NBREMSE VORN DISQUE FREIN AVANT	1 2 3 4	
12A		00H01206061	RADIO RUEDA DT. DR. RAGGIO RUOTA ANT. WHEEL ARM.	SPEICHE RAYON DE ROUE	1 2 3 4	
13A		00H01208191	R-CTO PINZA FRENO DT COMPLESSO GANASCIA FRENO ANTER LEFT-HAND FRONT CLIP ASSY	BREMSZANGE ENS. ETRIER DE FREIN	1 2 3 4	
14A		00H04703141	JUEGO PASTILLAS DE FRENO CONG. PASTIGLIE FRENO SET OF BRAKE PADS	DIE GESAMTHEIT BREMSBACKEN ENS. PLAQUETTE DE FREIN	1 2 3 4	
15A		00002083001	TORNILLO 8M125X30 VITE SCREW	SCHRAUBE VIS	1 2 3 4	
16A		00H01201331	PROTECTOR TUERCA PROTEZIONE PROTECTOR	ABDECKUNG PROTECTEUR	1 2 3 4	
17A		00034000802	ARANDELA ESTRELL. INT. D8 RONDELLA WASHER	SCHEIBE RONDELLE	1 2 3 4	
18A		00H00300672	TUERCA CAB. EJE BASCTE. DADO NUT	MUTTER ECROU	1 2 3 4	
19A		00H02402282	TORNILLO FIJ. BOQ. CARBURADOR VITE SCREW	SCHRAUBE VIS	1 2 3 4	
20A		00F04700121	R-CTO. PURGAD. PINZA FR. DT. R-COMPLESSO SPURGO GANASCIA FR FRONT BRAKE BLEED CLIP ASSY	ABLASSHAHN R-ENS. PURGEUR PINCE FREIN AV. F	1 2 3 4	

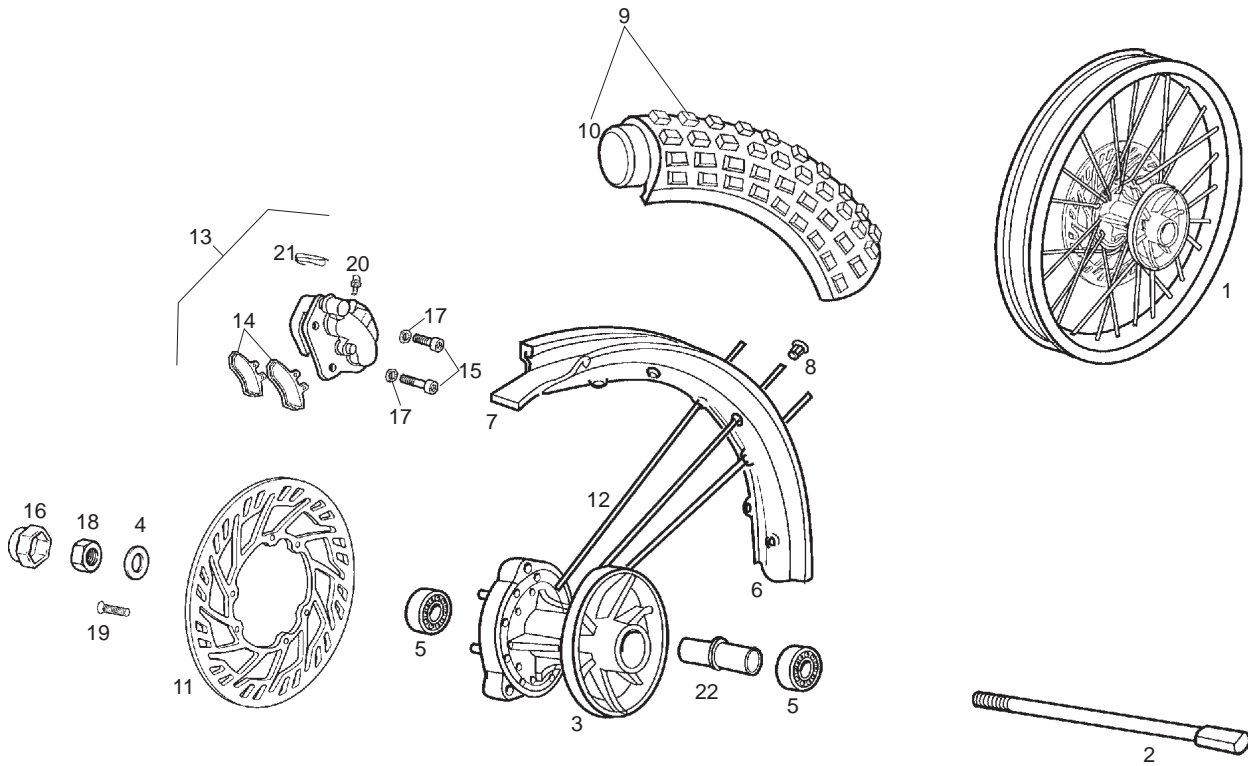

Fig.	Ver.	COD. KOD.	DESCRIPCIÓN DENOMINAZIONE NAME	BEZEICHNUNG DESIGNATION	MOD.	NOTAS NOTES NOTA MITSCHRIFT NOTES
21A		00H01301831	MUELLE FIJ. PASTILLA FRENO TR. MOLLA SPRING	FEDER RESSORT	1 2 3 4	
22A		00H01203031	SCTO. SEPARADOR COJINETES SEPARATORE CUSCINETTI SPACER BEARING	DISTANZHULSE SEP. ROULEMENTS MOYEU AR.	1 2 3 4	



**RUEDA SIN DISCO Y SIN PLATO  
WHEEL WITHOUT DISC AND DRIVE PLATE**

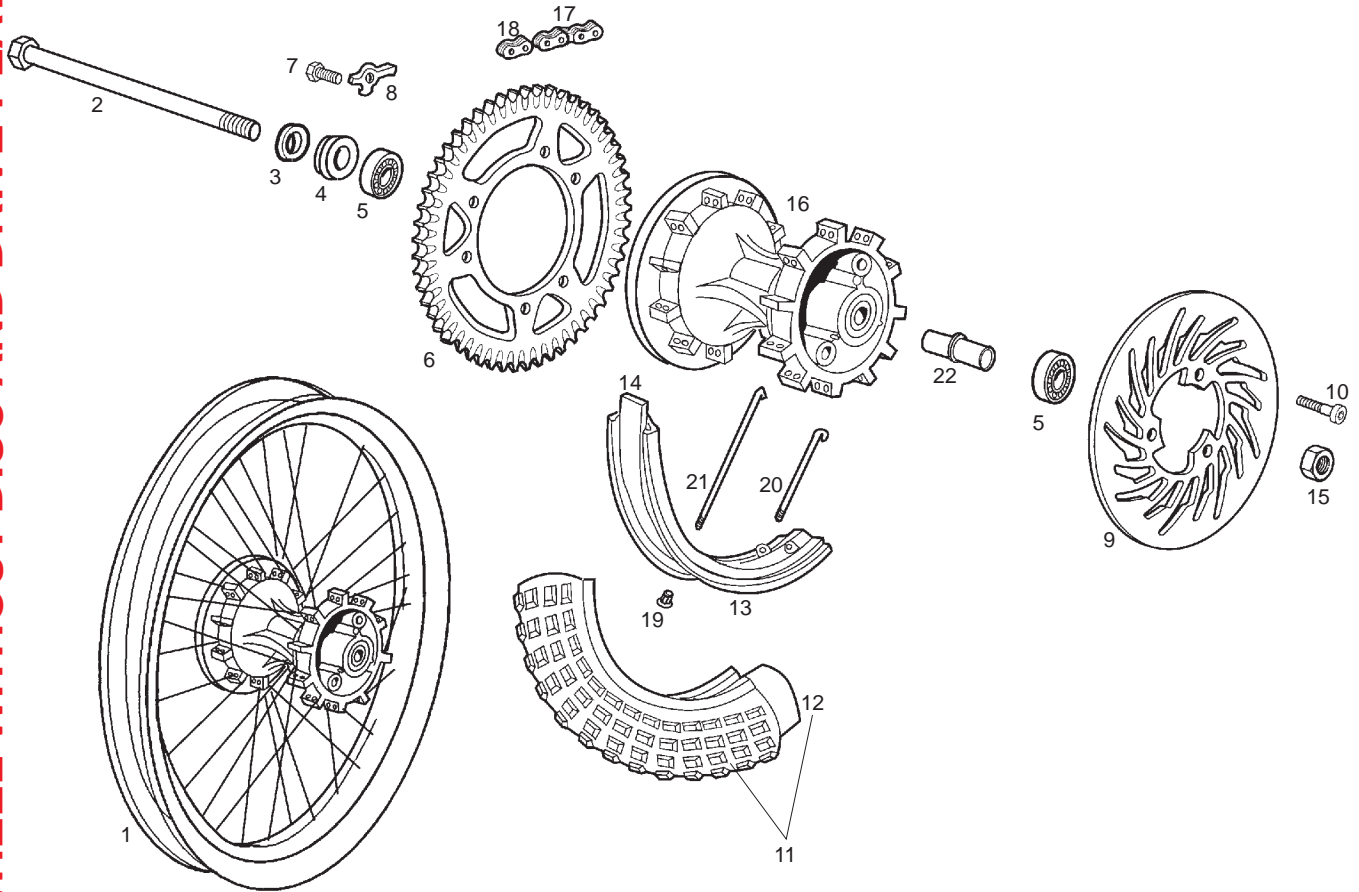
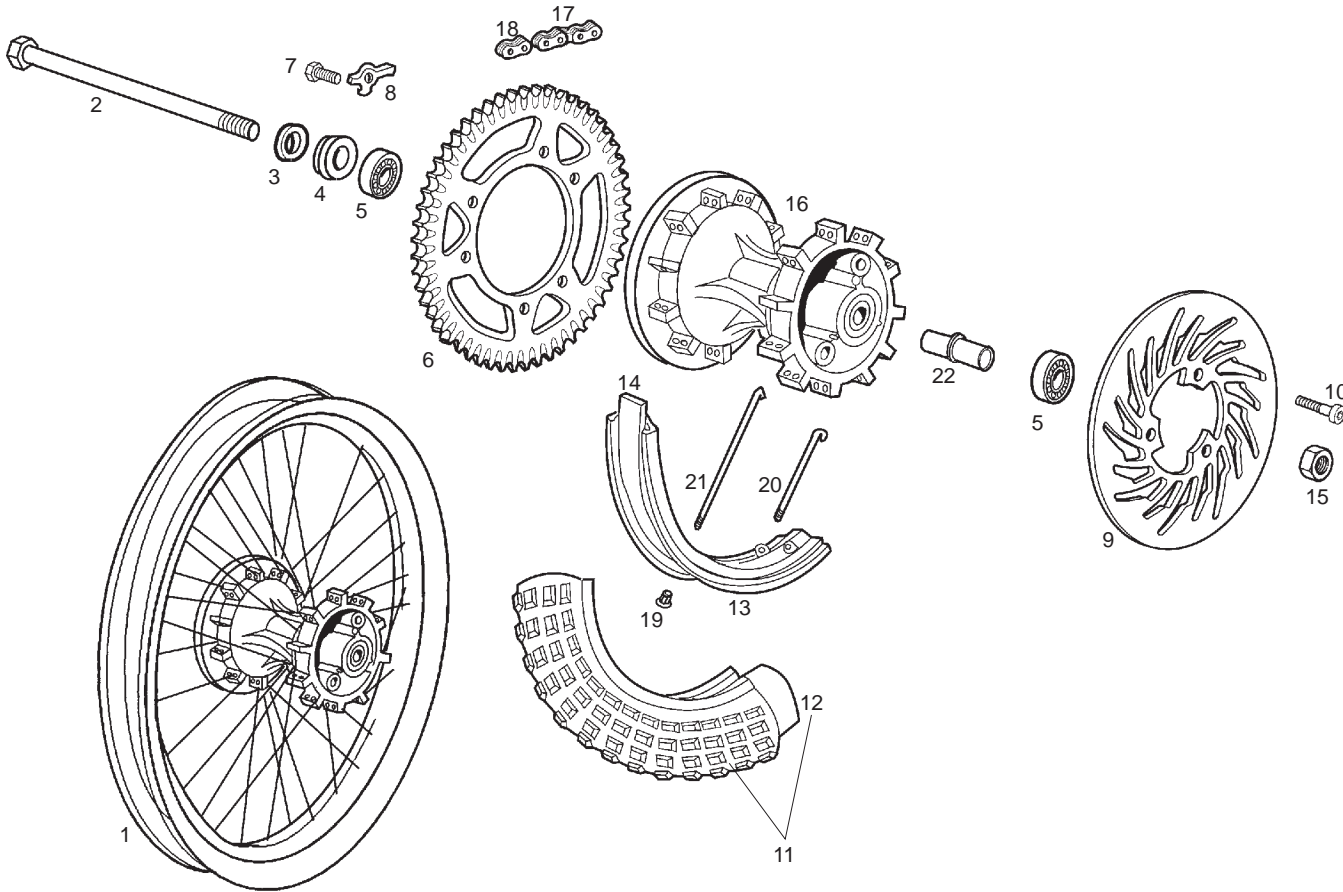

Fig.	Ver.	COD. KOD.	DESCRIPCIÓN DENOMINAZIONE NAME	BEZEICHNUNG DESIGNATION	MOD.	NOTAS NOTES NOTA MITSCHRIFT NOTES
01A		00H02411331	R-CTO.LLANTA TR.C/CARRETE SR RACING CERCHIONE POSTERIORE REAR RIM WITH HUB	HINTERRAD JANTE ARRIERE	1 2 3 4	
02A		00H01303201	CTO. EJE RDA. TR. SUBCOMPLESSO ASSE RUOTA POSTER REAR WHEEL AXLE SUB-ASSE.	U-GRUPPE HINTERRADACHSE S/ENSEMBLE AXE ROUE ARRIERE GP	1 2 3 4	
03A		00032015000	ARANDELA PLANA. D.15. RONDELLA WASHER	SCHEIBE RONDELLE	1 2 3 4	
04A		00H01306181	CASQUILLO BRONZINA BUSHING	BUCHSE ENTRETOISE	1 2 3 4	
05A		00000056202	COJINETE CUSCINETTO BEARING	LAGER COUSSINET	1 2 3 4	
06A		00H01331031	PLATO ARRASTRE Z-53 PIATTO TRAINO DRIVE PLATE	MITNEHMERSCHEIBE COURONNE ARRIERE	1 2 3 4	
07A		00002182000	TORNILLO C/EX.8M125X20 VITE SCREW	SCHRAUBE VIS	1 2 3 4	
08A		00H01302052	PRECINTO TOR. PLATO ARRAST. PIASTRINA VITE PIATTO TRASCINA BRAKE DISC RETAINER	SCHRAUBE MITNEHMERSCHEIBE ARRETOIR DES BOULONS DISQUE	1 2 3 4	
09A		00H01308531	DISCO FRENO TRASERO D220 DISCO FRENO POSTERIORE REAR BRAKE DISC	BREMSSCHEIBE HINTEN DISQUE DE FREIN ARRIERE	1 2 3 4	
10A		00H02401282	TORNILLO FIJ. DISCO FR. TR. VITE SCREW	SCHRAUBE VIS	1 2 3 4	



**RUEDA SIN DISCO Y SIN PLATO  
WHEEL WITHOUT DISC AND DRIVE PLATE**

Fig.	Ver.	COD. KOD.	DESCRIPCIÓN DENOMINAZIONE NAME	BEZEICHNUNG DESIGNATION	MOD.	NOTAS NOTES NOTA MITSCHRIFT NOTES
11A		00H01309321	CTO. CUBIERTA TRASERA 110/80-18" COPERTONE TYRE	REIFEN PNEU	1 2 3 4	
12A		00H01308361	CAMARA RDA. TR. CAMERA RUOTA POST. REAR WHEEL CAMBER	SCHLAUCH CHAMRE A AIR ARR.	1 2 3 4	
13A		00H01309352	LLANTA TRAS. CERCHIONE POSTERIORE REAR RIM	HINTERRADFELGE JANTE ARRIERE NUE.	1 2 3 4	
14A		00D01301401	PROTECTOR CAMARA PROTEZIONE CAMERA RUOTA POSTER RIM STRIP	FELGENBAND PROTECTEUR DE CHAMBRE A AIR	1 2 3 4	
15A		00H00300672	TUERCA CAB. EJE BASCTE. DADO NUT	MUTTER ECROU	1 2 3 4	
16A		00H01306824	CTO. CARRETE TR.'98 MOZZO POST. REAR COIL	RADNABE MOYEU ARRIERE	1 2 3 4	
17A		00H01502201	CADENA SEC. 130 CATENA SEZ. 130 TRANSMISSION CHAIN 130	KETTE 130 CHAINE TRANSMISSION 130	1 2 3 4	
18A		00H01501212	R-ENGANCHE DORAD. CADENA SEC. AGGANCIAMENTO CATENA SICUREZZA MASTER LINK	KETTENSCHLOSS ATTACHE RAPIDE	1 2 3 4	
19A		00002212070	TUERCA RADIO. DADO NUT	MUTTER ECROU	1 2 3 4	
20A		00H01301721	RADIO RUEDA TR. LADO DISCO SPEICHE REAR SHORT INNER SPOKE	SPEICHE RAYON ROUE AR INT. COURT	1 2 3 4	

**RUEDA SIN DISCO Y SIN PLATO  
WHEEL WITHOUT DISC AND DRIVE PLATE**

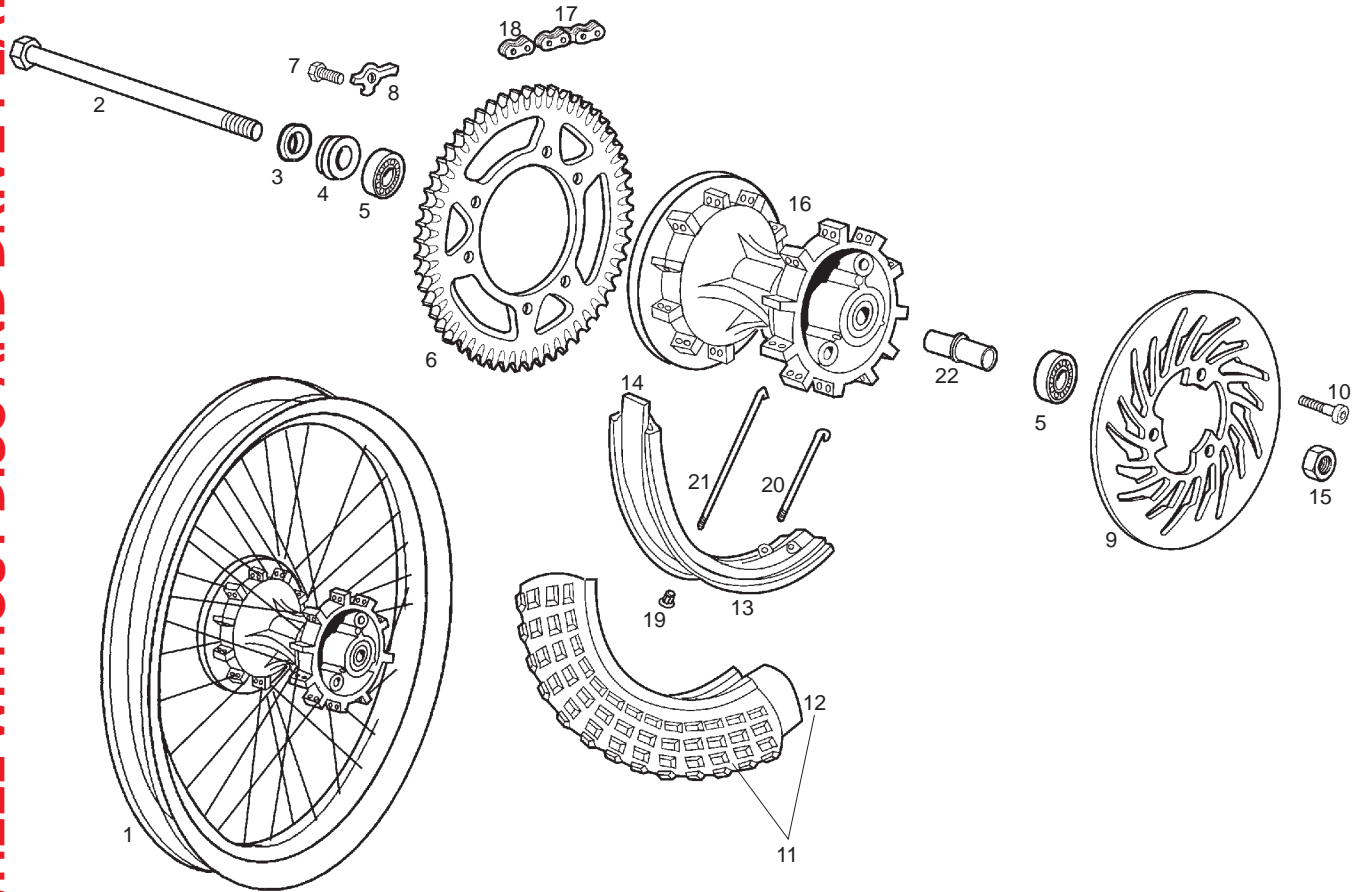

Fig.	Ver.	COD. KOD.	DESCRIPCIÓN DENOMINAZIONE NAME	BEZEICHNUNG DESIGNATION	MOD.	NOTAS NOTES NOTA MITSCHRIFT NOTES
21A		00H01303731	RADIO INT. TR. LADO PLATO RADIO POST. LATO PIATTO REAR INNER SPOKE	SPEICHE RAYON ROUE ARRIERE INT.	1 2 3 4	
22A		00H01303091	SCTO. SEPARADOR COJINETES SUBCOMPLESO SEPARATORE CUSCIN BEARING SPACER	DISTANZHULSE SEPARATEUR ROULEMENTS	1 2 3 4	

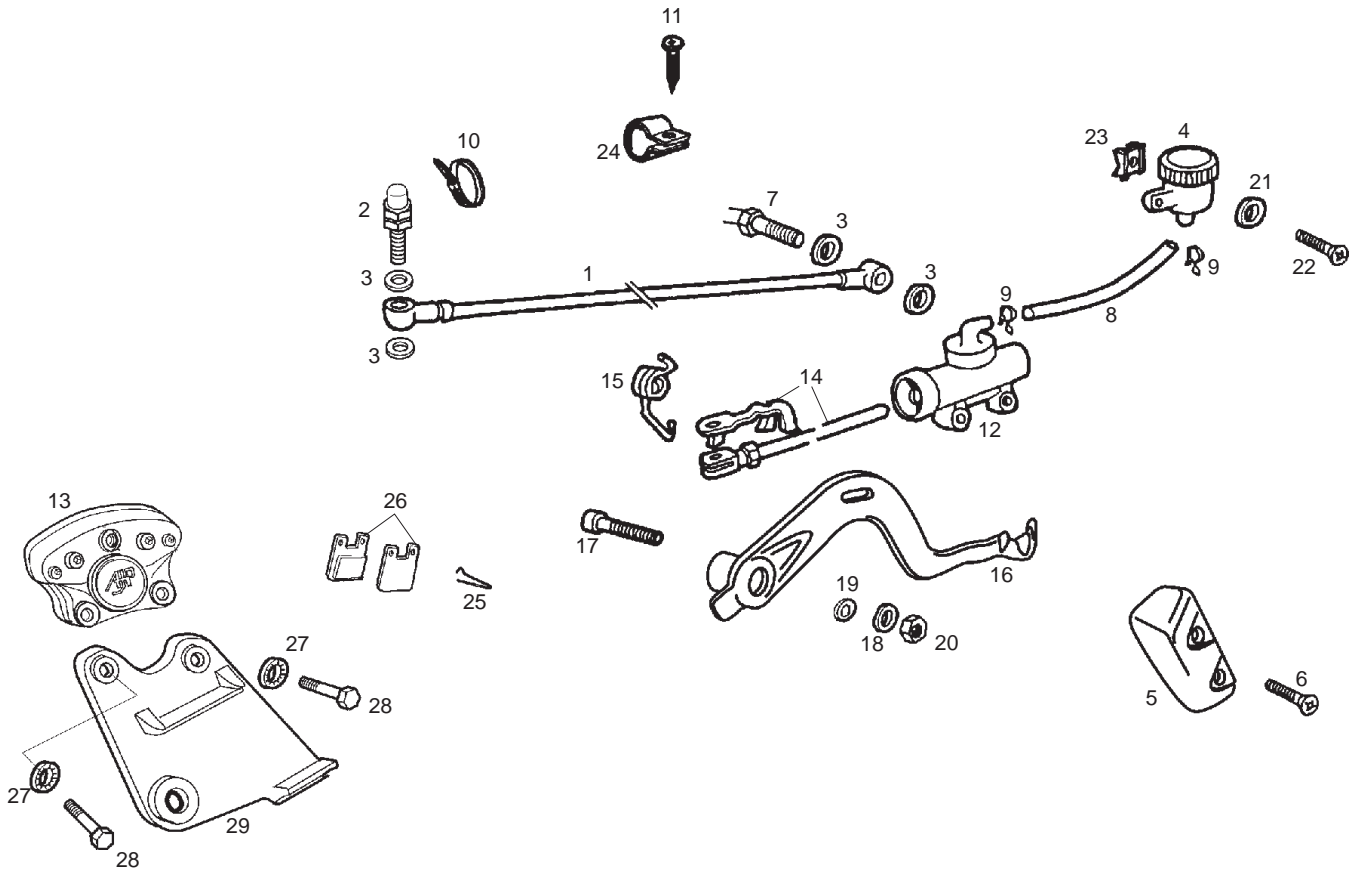

Fig.	Ver.	COD. KOD.	DESCRIPCIÓN DENOMINAZIONE NAME	BEZEICHNUNG DESIGNATION	MOD.	NOTAS NOTES NOTA MITSCHRIFT NOTES
01A		00H01111081	TUBO LIQUIDO FRENO TRAS. TUBO TUBE	ROHR TUYAU	1 2 3 4	
02A		00H04702121	CTO. PURGADOR PINZA SPURGO PINZA FRENO BRAKE BLEED CLIP ASSY	ABLASSHAHN R-ENS. PURGEUR PINCE	1 2 3 4	
03A		00006321040	ARANDELA JUNTA RACORD RONDELLA WASHER	SCHEIBE RONDELLE	1 2 3 4	
04A		00D01100201	CTO. DPSTO. LIQ. FRENO TRAS. SERBATOIO LIQUIDO FR FLUID TUBE TANK	BEHALTER RESERVOIR FLUID TUBE	1 2 3 4	
05A		00H01101731	PROTECT. BOMBA. LIQ. FR. TR. PROTEZIONE FRENO POSTERIORE REAR BRAKE, PROTECTOR	ABDECKUNG PROTECTEUR ENS. COMMANDE FRE	1 2 3 4	
06A		00G01503701	TORNILLO FIJ. ESC. FRONTAL VITE SCREW	SCHRAUBE VIS	1 2 3 4	
07A		00H01001701	CTO. INTERRUPTOR STOP COMP. INTERRUPTORE FANALINO SWITCH, STOP LIGHT	STOPCHALTER VO. INTERRUPTEUR COMMANDE STOP	1 2 3 4	
08A		00H01103211	TUBO DEPOSITO A BOMBA TUBO TUBE	ROHR TUYAU	1 2 3 4	
09A		00H03700131	ABRAZADERA ELASTICA FASCETTA CLAMP	KLAMMER CRAMPON	1 2 3 4	
10A		00F00900531	BRIDA BRIGLIA BRIDLE	ZÜGEL BRIDE	1 2 3 4	
11A		00011041300	TORNILLO AUT. C/CR. NG.4,8X13. VITE SCREW	SCHRAUBE VIS	1 2 3 4	

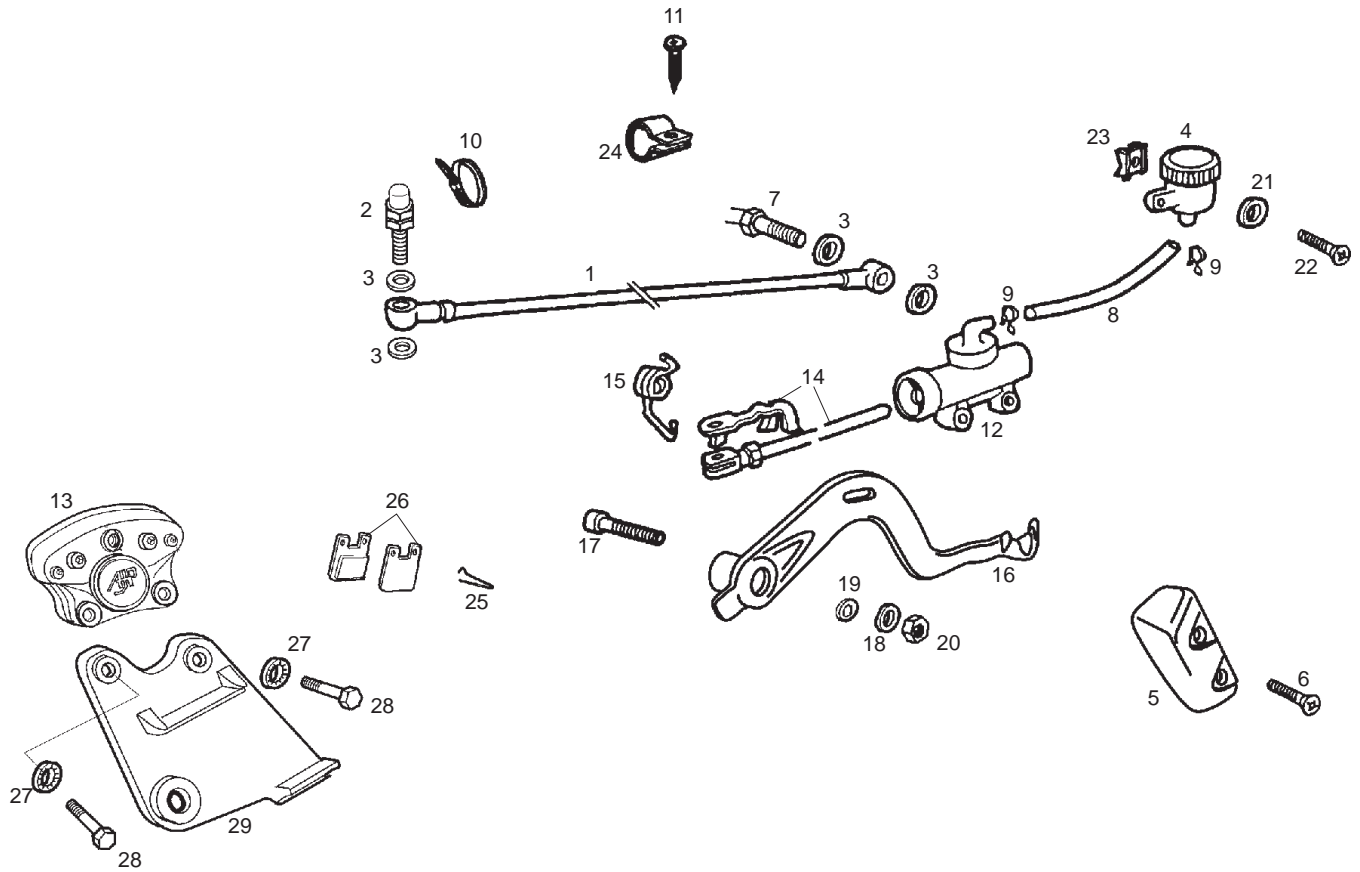

Fig.	Ver.	COD. KOD.	DESCRIPCIÓN DENOMINAZIONE NAME	BEZEICHNUNG DESIGNATION	MOD.	NOTAS NOTES NOTA MITSCHRIFT NOTES
12A		00H01106181	R-CTO BOMBA FRENO TRASERO DRD FRENO POSTERIORE REAR BRAKE CONTROL ASSY	REAR BRAKE CONTROL ASSY. ENSEMBLE COMMANDE FREIN ARRIER	1 2 3 4	
13A		00H01110581	R-CTO PINZA FRENO TRASERO COMPLESSO GANASCIA POSTERIORE REAR CLIP ASSEMBLY	BREMSZANGE HINTEN ETRIER FREIN ARR.	1 2 3 4	
14A		00H01103611	CTO.VARILLA BOMBA FR. TR. COMP. ASTA POMPA FRENO REAR BRAKE ROD	BREMSSTANGE TIGE DE FREIN ARRIERE	1 2 3 4	
15A		00H01102072	MUELLE PEDAL FRENO TRAS. MOLLA SPRING	FEDER RESSORT	1 2 3 4	
16A		00H01120021	PALANCA FRENO PEDALE FRENO BRAKE PEDAL	FUSSBREMSHEBEL PEDALE DE FREIN AR.	1 2 3 4	
17A		00H01100172	TORNILLO FIJ. PALANCA FR. TRAS. VITE SCREW	SCHRAUBE VIS	1 2 3 4	
18A		00402080001	ARANDELA PLANA MECANIZ. D8 RONDELLA WASHER	SCHEIBE RONDELLE	1 2 3 4	
19A		00005527540	ARANDELA REG. TOR. PAL. FIJ. RONDELLA WASHER	SCHEIBE RONDELLE	1 2 3 4	
20A		00023108000	TUERCA AUTOBLOC. 8M125 DADO NUT	MUTTER ECROU	1 2 3 4	
21A		00D02600631	ARANDELA TOPE MUELLE EMBRAGUE RONDELLA WASHER	SCHEIBE RONDELLE	1 2 3 4	
22A		00012151500	TORNILLO C/RED. ALL.5M100X16 VITE SCREW	SCHRAUBE VIS	1 2 3 4	

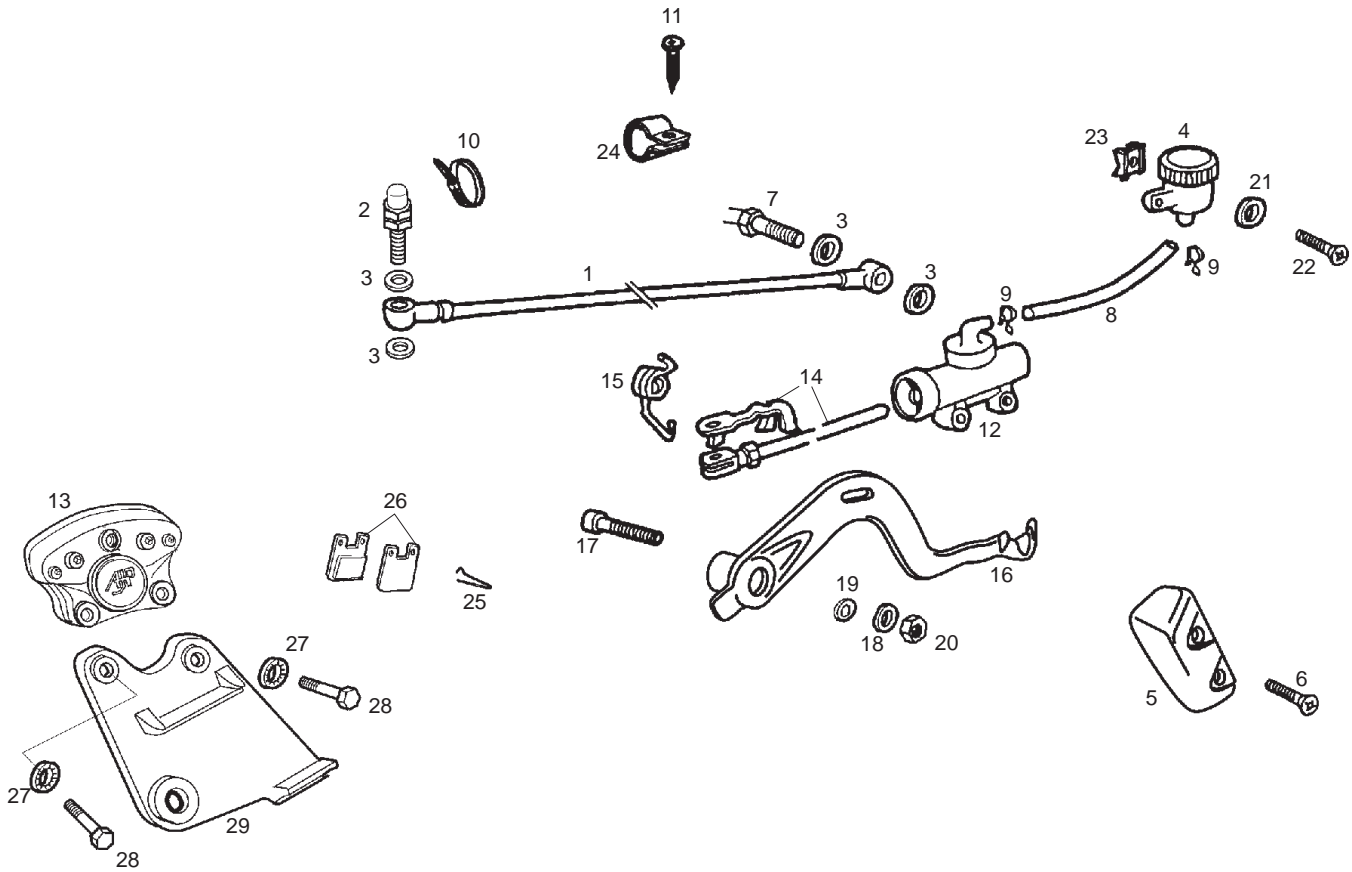

Fig.	Ver.	COD. KOD.	DESCRIPCIÓN DENOMINAZIONE NAME	BEZEICHNUNG DESIGNATION	MOD.	NOTAS NOTES NOTA MITSCHRIFT NOTES
23A		00G04401462	TUERCA FIJ. CUBRECADENA DADO NUT	MUTTER ECROU	1 2 3 4	
24A		00H01501811	BRIDA BRIGLIA BRIDLE	ZÜGEL BRIDE	1 2 3 4	
25A		00H04701171	MUELLE FIJACION PASTILLAS MOLLA SPRING	FEDER RESSORT	1 2 3 4	
26A		00G04700141	JUEGO PASTILLAS DE FRENO CONG. PASTIGLIE FRENO SET OF BRAKE PADS	DIE GESAMTHEIT BREMSBACKEN ENS. PLAQUETTE DE FREIN	1 2 3 4	
27A		00034000802	ARANDELA ESTRELL. INT. DS. RONDELLA WASHER	SCHEIBE RONDELLE	1 2 3 4	
28A		00002083001	TORNILLO 8M125X30 VITE SCREW	SCHRAUBE VIS	1 2 3 4	
29A		00H01303521	SCTO. SOPTE. PINZA FR. TR. SUBCOMPLESSO SUPPORTO GANASCIA REAR BRAKE CALIPER BRACKET SUB	U-GRUPPE HINTERBREMSBACKEN S/ENSEMBLE SUPPORT PINCE FREIN	1 2 3 4	

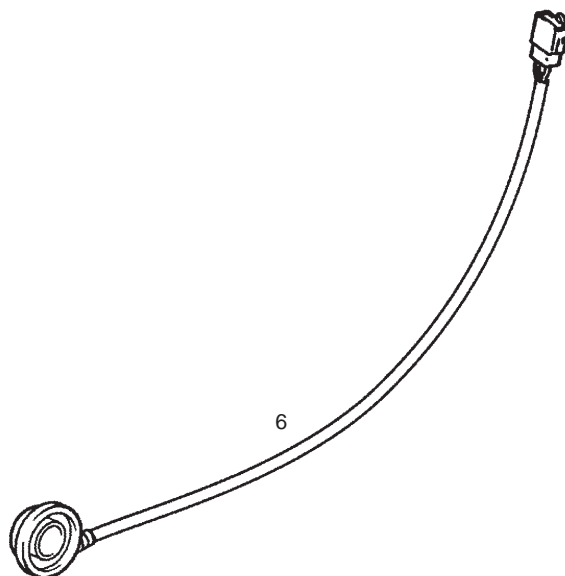
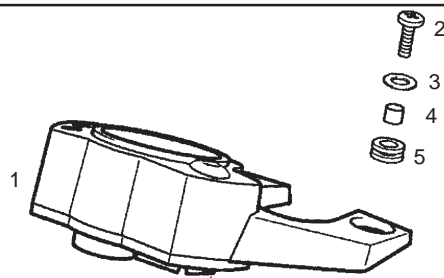

Fig.	Ver.	COD. KOD.	DESCRIPCIÓN DENOMINAZIONE NAME	BEZEICHNUNG DESIGNATION	MOD.	NOTAS NOTES NOTA MITSCHRIFT NOTES
01A		00H01632521	CTO. TABLIER PORTAINST. KMH CRUSCOTTO DASHASSY	INSTRUMENTERHALTER BOITIER TABLEAU BORD	1 2 3 4	
01B		00H01636521	CTO. TABLIER PORTAINST. MPH CRUSCOTTO DASHASSY	INSTRUMENTERHALTER BOITIER TABLEAU BORD	1 3	ONLY ENGLAND
02A		00012152000	TORNILLO C/RED.CRUIZ 5M80X20 VITE SCREW	SCHRAUBE VIS	1 2 3 4	
03A		00D02600631	ARANDELA RONDELLA WASHER	SCHEIBE RONDELLE	1 2 3 4	
04A		00H01600911	CASQUILLO BRONZINA BUSHING	BUCHSE ENTRETOISE	1 2 3 4	
05A		00D01500021	PASACABLE PORTACAVI GROMMET	GUMMI PASSE-CABLE	1 2 3 4	
06A		00H01615051	CTO.REENVIO RINVIO RETURN UNIT.	RETURN UNIT. RENVOI DE ROUE	1 2 3 4	



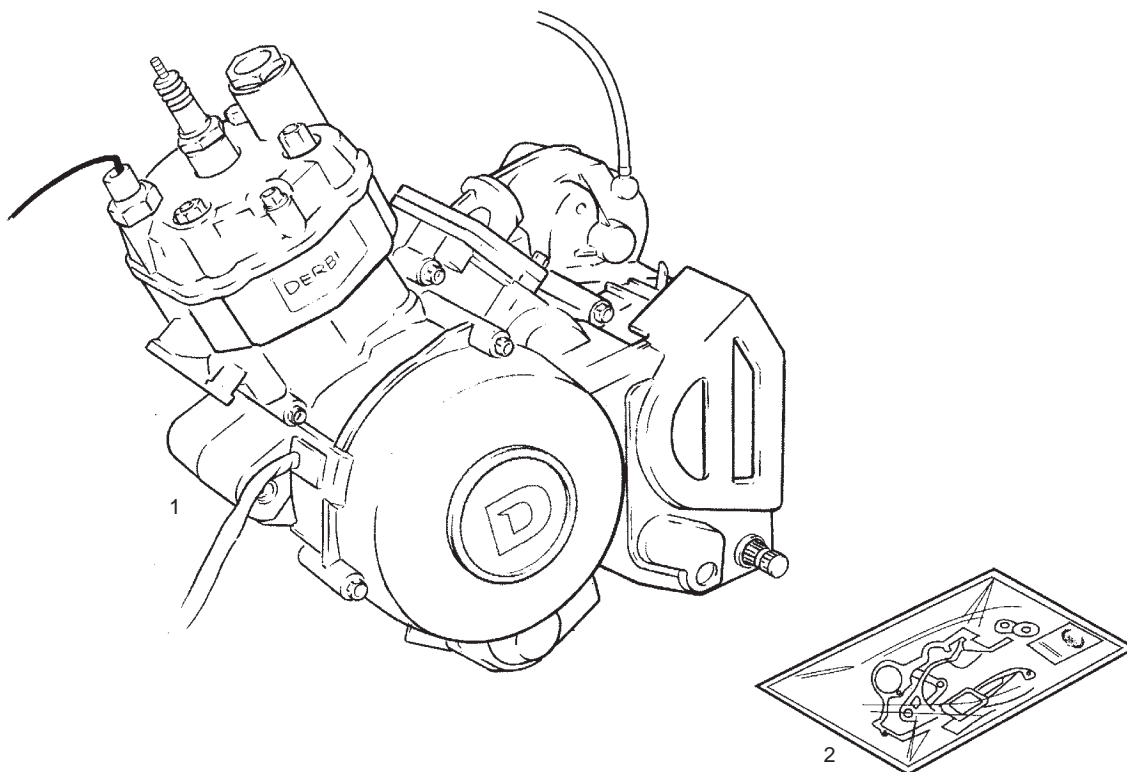

Fig.	Ver.	COD. KOD.	DESCRIPCIÓN DENOMINAZIONE NAME	BEZEICHNUNG DESIGNATION	MOD.	NOTAS NOTES NOTA MITSCHRIFT NOTES
01A		00H99927E303	MOTOR MOTORE ENGINE	MOTOR MOTEUR	1 2 3 4	
02A		00H05205481	R-JUEGO JUNTAS R-GUARNIZIONI GASKET ASSY	DICHTSATZ POCHETTE DE JOINTS	1 2 3 4	

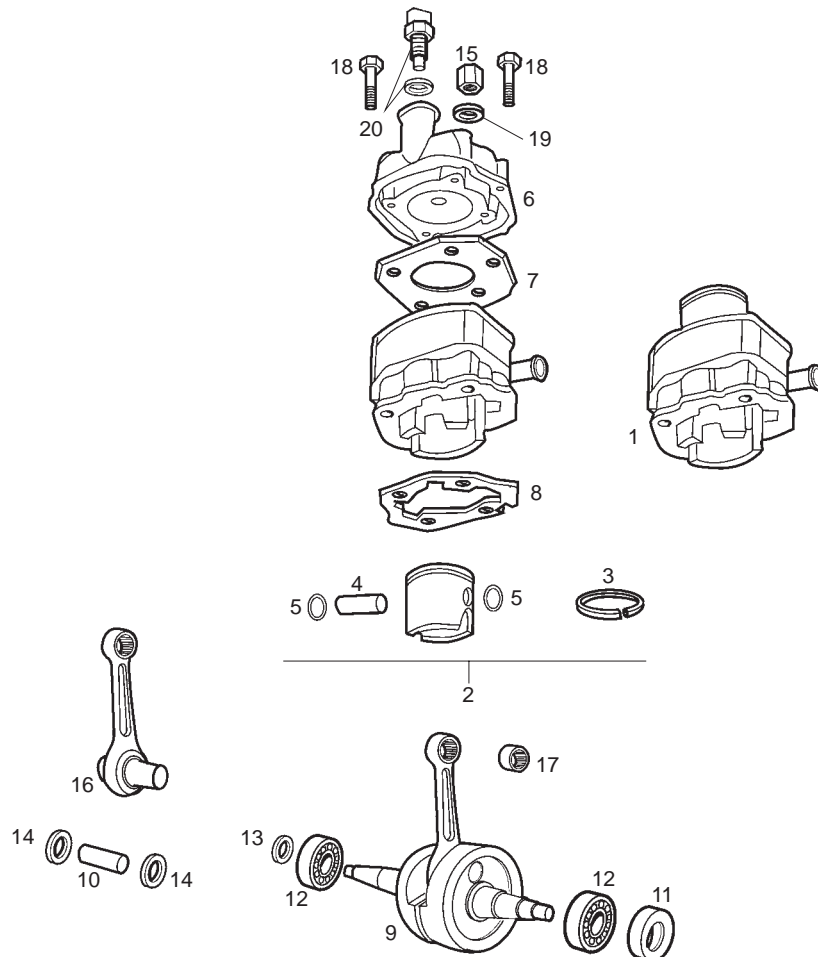

Fig.	Ver.	COD. KOD.	DESCRIPCIÓN DENOMINAZIONE NAME	BEZEICHNUNG DESIGNATION	MOD.	NOTAS NOTES NOTA MITSCHRIFT NOTES
01A		00H05007123	R-CTO. CILIN.-PISTON COMP. CILINDRO PISTONE CYLINDER PISTON ASSEMBLY	ZYLINDER UND KOLBEN CYLINDRE ET PISTON COMPLET	1 2 3 4	
02A		00H02542091	CTO. PISTON (A) PISTONE (A) PISTON (A)	KOLBEN KOMPL.(A) PISTON-COMPLET (A)	1 2 3 4	
02B		00H02552091	CTO. PISTON (B) PISTONE (B) PISTON (B)	KOLBEN KOMPL. (B) PISTON-COMPLET (B)	1 2 3 4	
02C		00H02562091	CTO. PISTON (C) PISTONE (C) PISTON (C)	KOLBEN KOMPL. (C) PISTON-COMPLET (C)	1 2 3 4	
02D		00H02572091	CTO. PISTON (D) PISTONE (D) PISTON (D)	KOLBEN KOMPL. (D) PISTON-COMPLET (D)	1 2 3 4	
03A		00H02502111	R-ARO PISTON (ASSO) R-SEGMENTO PISTONE PISTON RING	KOLBENDICHTRING SEGMENT DE PISTON	1 2 3 4	
04A		00H02502121	R-BULON PISTON 6V (ASSO) SPINOTTO PISTONE PISTON PIN	KOLBENBOLZEN AXE PISTON	1 2 3 4	
05A		00H02501131	R-ANILLO BULON 6V (ASSO) R-SEGMENTO SPINOTTO CIRCLIP, PISTON PIN	SICHERUNGSRING CLIPS AXE PISTON	1 2 3 4	
06A		00H02512013	CULATA TESTATA CYLINDER HEAD	ZYLINDERKOPF CULASSE	1 2 3 4	
07A		00H02505021	JUNTA CULATA. GUARNIZIONE GASKET	DICHTUNG JOINT	1 2 3 4	

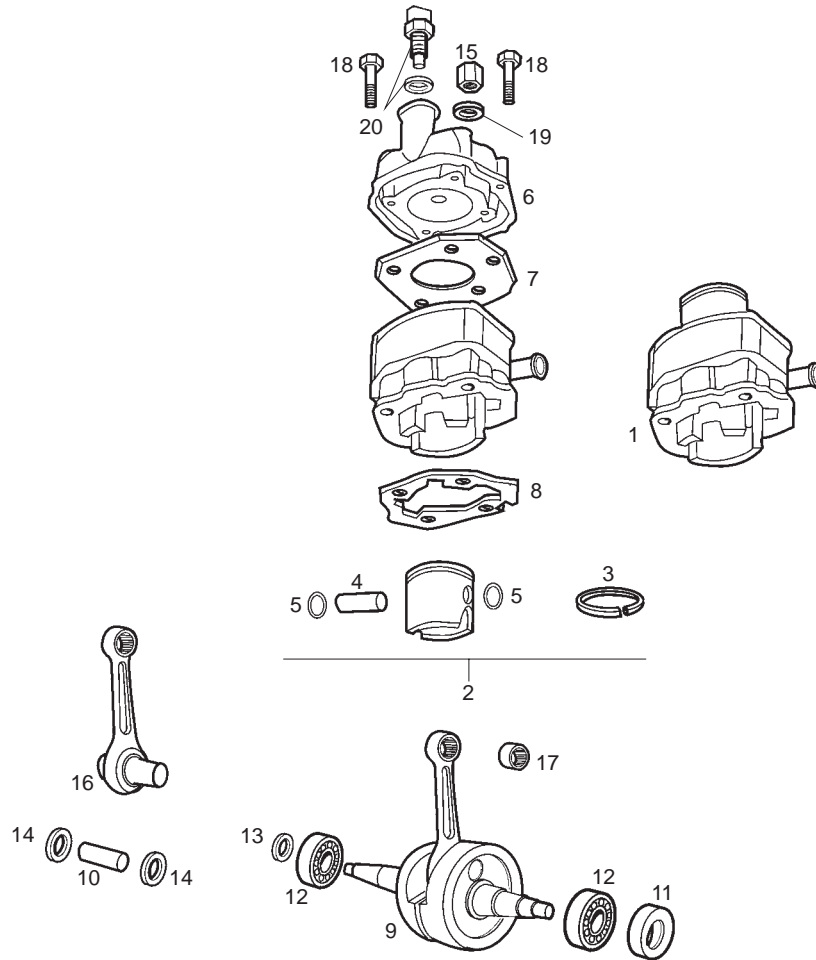

Fig.	Ver.	COD. KOD.	DESCRIPCIÓN DENOMINAZIONE NAME	BEZEICHNUNG DESIGNATION	MOD.	NOTAS NOTES NOTA MITSCHRIFT NOTES
08A		00H02500041	JUNTA CILINDRO. GUARNIZIONE GASKET	DICHTUNG JOINT	1 2 3 4	
09A		00H02506141	CTO. CIGÑ.-BIELA. 2000 ALBERO GOMITO-BIELLA CRANK SHAFT ROD.	KURBELWELLE VILEBREQUIN COMPLET	1 2 3 4	
10A		00002025190	EJE CUELLO CIGÑAL. 16.4-6V. ASSE COLLO ALBERO GOMITO 16.4- CRANKSHAFT PIN	PLEUEL BOLZEN AXE DE VILLEBREQUIN	1 2 3 4	
11A		00H02500301	RETEN CIGUEÑAL GIUNTO TENUTA SEAL	DICHTRING JOINT	1 2 3 4	
12A		00059220400	COJINETE CUSCINETTO BEARING	LAGER COUSSINET	1 2 3 4	
13A		00E02500231	RETEN CIGUEÑAL GIUNTO TENUTA SEAL	DICHTRING JOINT	1 2 3 4	
14A		00002225220	ARANDELA REG. CAB. BIELA. RONDELLA WASHER	SCHEIBE RONDELLE	1 2 3 4	
15A		00008202730	TUERCA FIJ. MANILL.-CULATA. DADO NUT	MUTTER ECROU	1 2 3 4	
16A		00H05001011	R-CTO. BIELA. R-BIELLA CONNECTING ROD W/BEARING AND P	PLEUEL BIELLE AVEC CAGE ET AXE	1 2 3 4	
17A		00002125170	JAULA PIE BIELA. KBK-12.15.15. GABBIA PIEDE BIELLA KBK12.15.1 BEARING, PISTON PIN	NADELLAGER CAGE A AIGUILLE DE PIED DE	1 2 3 4	

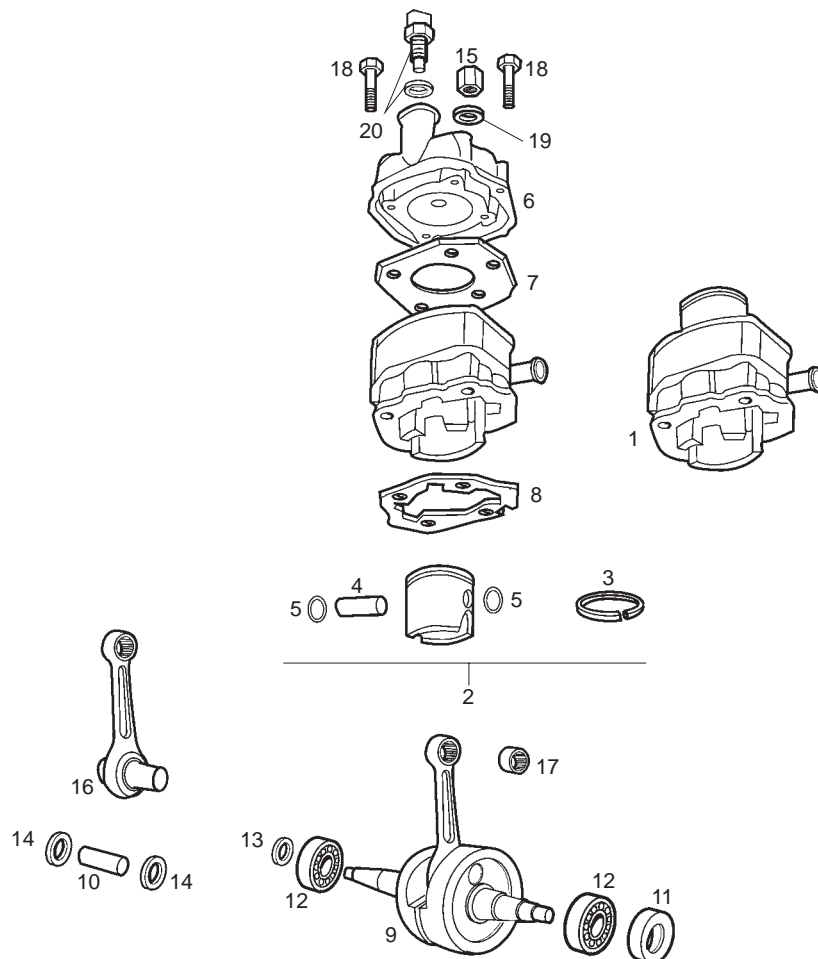

Fig.	Ver.	COD. KOD.	DESCRIPCIÓN DENOMINAZIONE NAME	BEZEICHNUNG DESIGNATION	MOD.	NOTAS NOTES NOTA MITSCHRIFT NOTES
18A		00H05001551	TORNILLO FIJACION CULATA VITE SCREW	SCHRAUBE VIS	1 2 3 4	
19A		00003125280	ARANDELA FIJ. CULATA. RONDELLA WASHER	SCHEIBE RONDELLE	1 2 3 4	
20A		00H02303441	TERMOCONTACTO TERMOCONTATTO. CLUTCH PLATE	THERMOKONTAKT TERMOCONTATTO.	1 2 3 4	

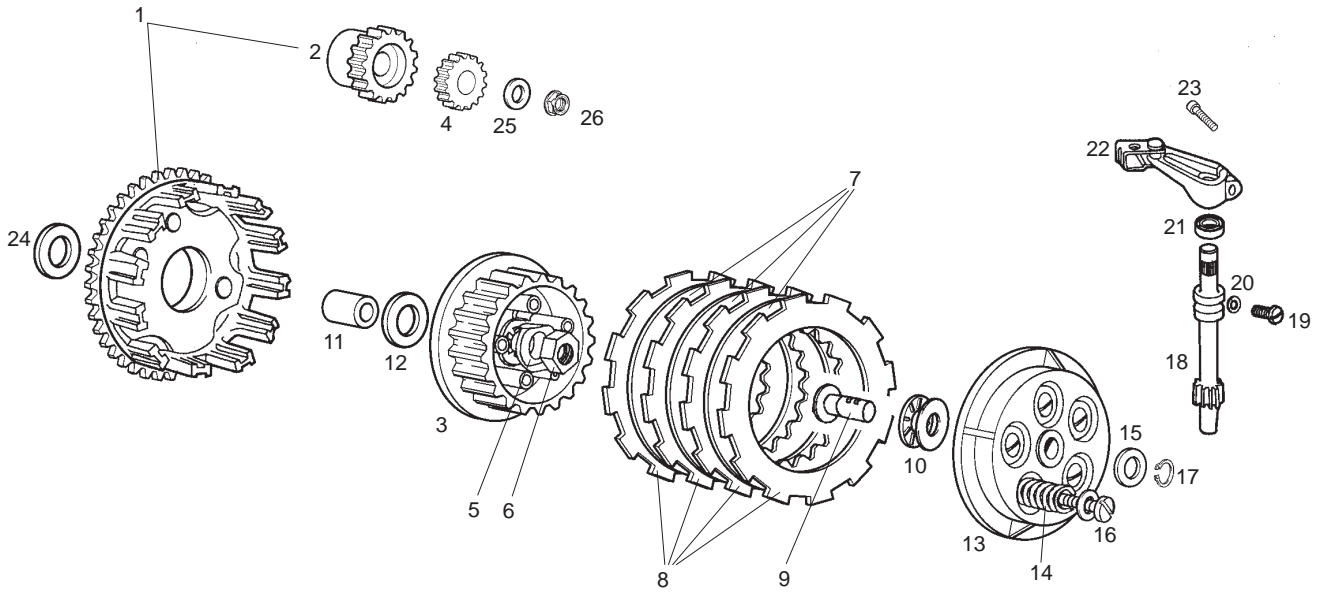

Fig.	Ver.	COD. KOD.	DESCRIPCIÓN DENOMINAZIONE NAME	BEZEICHNUNG DESIGNATION	MOD.	NOTAS NOTES NOTA MITSCHRIFT NOTES
01A		00H03603521	R-CTO RUEDA EMBRAGUE R-RUOTA FRIZIONE CLUTCH HOUSING AND DAMPER	KUPPLUNGSRAD CLOCHE EMBRAYAGE AVEC PIGNO	1 2 3 4	
02A		00H02601381	PIÑÓN MOTOR. Z-22. PIGNONE MOTORE . Z-22 PRIMAY GEAR Z-22	MOTORRITZEL Z-22 PIGNON PRIMAIRE Z-22	1 2 3 4	
03A		00H02600111	CAMPANA CONDUCIDA.4-6V. A. A. CAMPANA GUIDATA 4-6V. A. A. CLUTCH HUB.	GLOCKE TAMBOUR EMBRAYAGE	1 2 3 4	
04A		00H03800181	PIÑÓN MANDO BOMBAS. Z-14.74/80C PIGNONE COMANDO POMPE Z-14.7 PUMP GUIDE GEAR	RITZEL PIGNON	1 2 3 4	
05A		00006826230	PRECINTO TUERCA EMBRG. PIASTRINA DADO FRIZIONE WASHER, RETAINING	SICHERUNG FREIN DIECROU DIEMBAYAGE	1 2 3 4	
06A		00000326260	TUERCA EMBRAGUE DADO NUT	MUTTER ECROU	1 2 3 4	
07A		00H02600151	DISCO CONDUCIDO.74/80CC. DISCO GUIDATO 74/80CC DRIVEN CLUTCH PLATE	SCHEIBE DISQUE EMBRAYAGE LISSE	1 2 3 4	
08A		00H02601161	SCTO. DISCO CONDUCTOR.74/80CC. SUBDISCO GUIDA 74/80 CLUTCH PLATE	KUPPLUNGSRELAG DISQUE EMBRAYAGE GARNI	1 2 3 4	
09A		00H02600271	CREMALLERA EMPUJE EMBRG.74/80C CREMAGLIERA SPINTA FRIZIONE.74 PUSHING CLUTCH	ZAHNSTANGE CREMAILLETE D,EMBAYAGE	1 2 3 4	
10A		00H02600551	RODAMTO. AXIAL CREMALL. EMBRG. CUSCINETTO SFERE RADIALE CREMA BALL BEARING	LAGER ROULEMENT AXIAL	1 2 3 4	
11A		00H02601011	CASQUILLO BRONZINA BUSHING	BUCHSE ENTRETOISE	1 2 3 4	

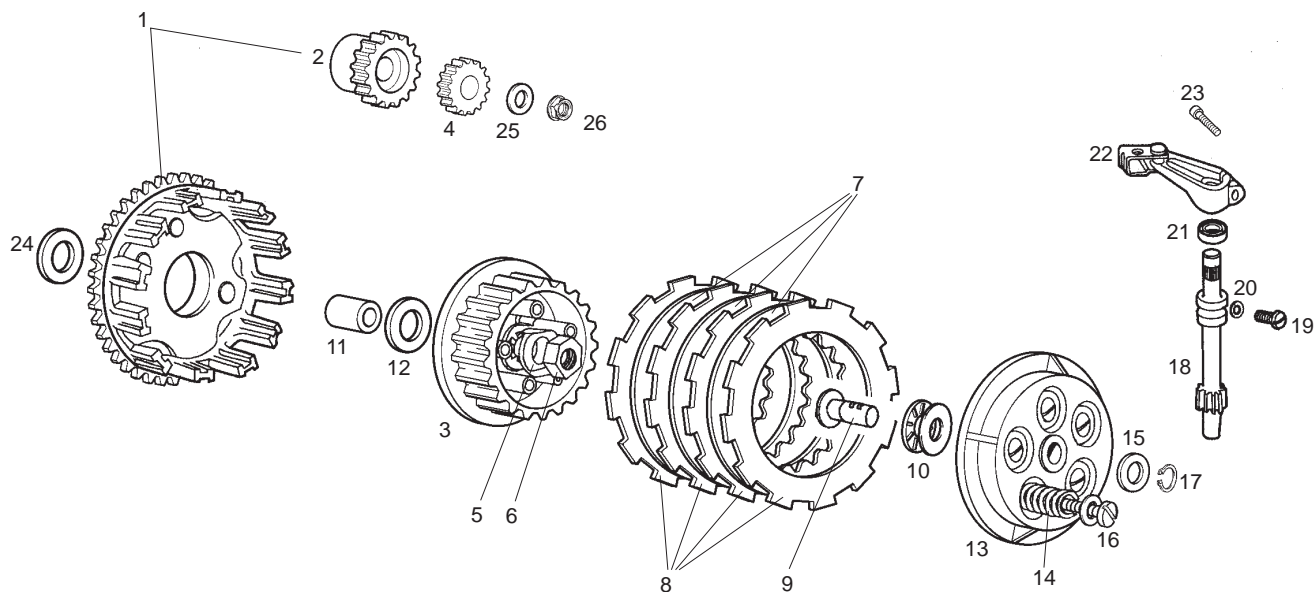

Fig.	Ver.	COD. KOD.	DESCRIPCIÓN DENOMINAZIONE NAME	BEZEICHUNG DESIGNATION	MOD.	NOTAS NOTES NOTA MITSCHRIFT NOTES
12A		00D02600552	ARANDELA ROZAMTO. CAMPANA. RONDELLA WASHER	SCHEIBE RONDELLE	1 2 3 4	
13A		00H02600181	TAPA CIERRE EMBRAG.6V.74-80CC. COPERCHIO COVER	DECKEL COUVERCLE	1 2 3 4	
14A		00H02600211	MUELLE REGULAC. EMBRAGUE MOLLA SPRING	FEDER RESSORT	1 2 3 4	
15A		00H05000281	ARANDELA TOPE PIÑON INTERMD. RONDELLA WASHER	SCHEIBE RONDELLE	1 2 3 4	
16A		00H05901781	SCTO. TORNILLO 5M80X35 VITE SCREW	SCHRAUBE VIS	1 2 3 4	
17A		00000047110	ANILLO SEGURIDAD EJES D10 ANELLO SICUREZZA CIRCLIP	SICHERHEITSRING ANNEAU SECURITE	1 2 3 4	
18A		00H02610311	EJE DESEMBRAGUE.74CC. ASSE DISINNESCO FRIZIONE 74CC CLUTCH SHAFT	KUPPLUNGSACHSE AXE	1 2 3 4	
19A		00H02600342	TORNILLO FIJ. EJE DESEMB. VITE SCREW	SCHRAUBE VIS	1 2 3 4	
20A		00H03800441	ARANDELA TOR.VACIADO AGUA RONDELLA WASHER	SCHEIBE RONDELLE	1 2 3 4	
21A		00002027280	RET. EJE MANDO SELEC.12.20.5. SD RICHIAMO ASSE COMANDO SELETTOR OIL SEAL, SELECTOR SHAFT	SIMMERRING JOINT ANTI-FUITE	1 2 3 4	
22A		00H02600322	SCTO. PALANCA DESEMBRG.. SUBLEVA DISINNESCO F CLUTCH LEVER	KUPPLUNGSHEBEL LEVIER EMBRAYAGE	1 2 3 4	

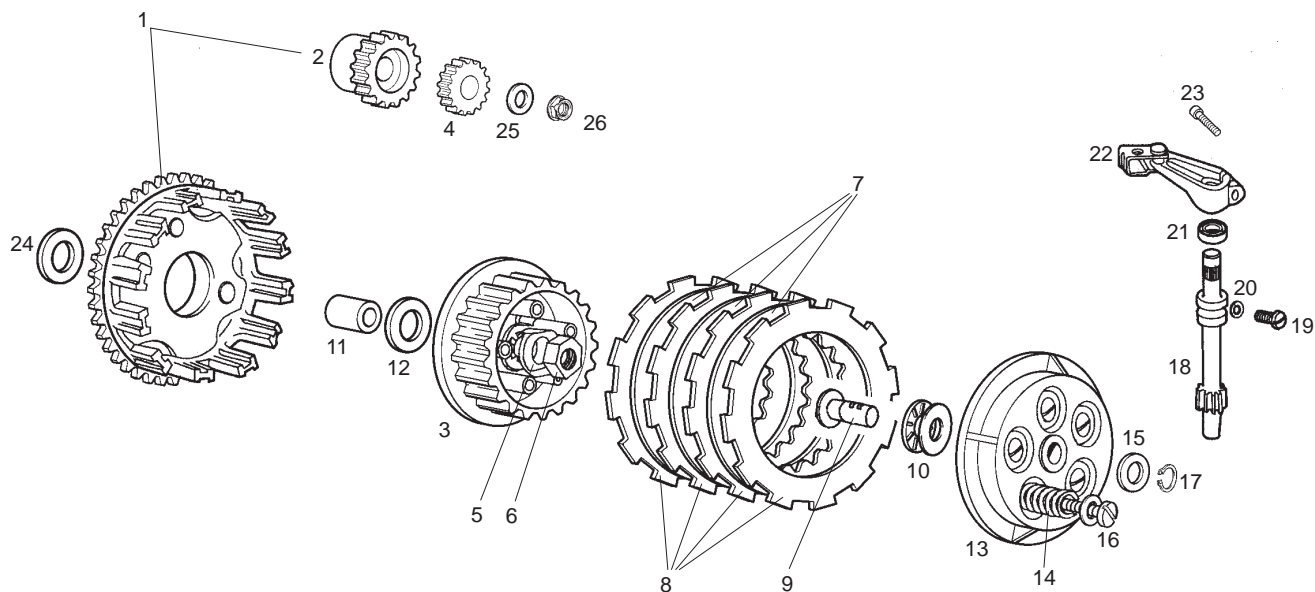

Fig.	Ver.	COD. KOD.	DESCRIPCIÓN DENOMINAZIONE NAME	BEZEICHNUNG DESIGNATION	MOD.	NOTAS NOTES NOTA MITSCHRIFT NOTES
23A		00052062011	TORNILLO 6M100X20 VITE SCREW	SCHRAUBE VIS	1 2 3 4	
24A		00002026020	ARANDELA PROTEC. INT. BUJE EMBRAG. RONDELLA WASHER	SCHEIBE RONDELLE	1 2 3 4	
25A		00H02600651	ARANDELA FIJ. PIÑON MOTOR RONDELLA WASHER	SCHEIBE RONDELLE	1 2 3 4	
26A		00H02600401	TUERCA FIJ. PIÑON MOTOR DADO NUT	MUTTER ECROU	1 2 3 4	



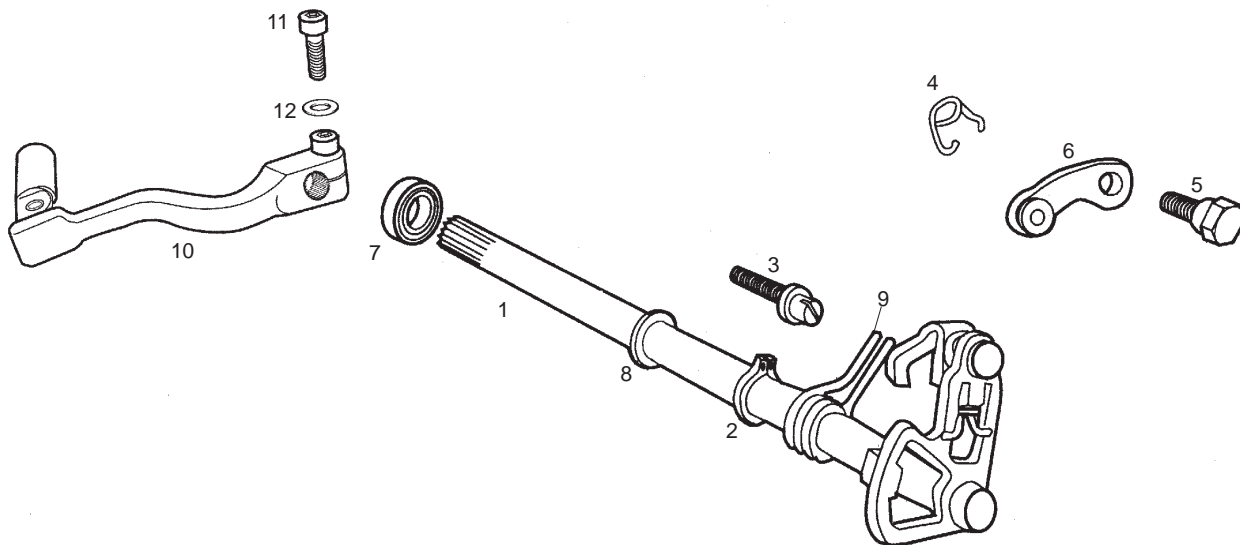

Fig.	Ver.	COD. KOD.	DESCRIPCIÓN DENOMINAZIONE NAME	BEZEICHNUNG DESIGNATION	MOD.	NOTAS NOTES NOTA MITSCHRIFT NOTES
01A		00H02700151	SCTO. EJE SELECTOR.74CC. SUBASSE SELETTORE 74 S-ASSY. SELECTOR SHAFT	SCHALTACHSE S-ENSEMBLE AXE SELECTEUR	1 2 3 4	
02A		00047031100	ANILLO SEGURIDAD EJES D12 ANELLO SICUREZZA CIRCLIP	SICHERHEITSRING ANNEAU SECURITE	1 2 3 4	
03A		00H02700231	ESPARRG. MUELLE SELEC.74/80CC. BULLONE MOLLA SELETTORE 74/80C SCREW, SELECTOR SPRING ADJ.	FEDERSTIFT AXE EXCENTRIQUE	1 2 3 4	
04A		00H02700441	MUELLE FIJ. MARCHAS MOLLA SPRING	FEDER RESSORT	1 2 3 4	
05A		00H02700451	TORNILLO GUIA FIJ. MARCHAS VITE SCREW	SCHRAUBE VIS	1 2 3 4	
06A		00H02700491	SCTO. PALANCA FIJ. MARCHAS.74CC. SUBLEVA FISSAGGIO MA LEVER FIXING GEARS	GANSCHALTHEEEL LEVIER FIXATION PIGNONS	1 2 3 4	
07A		00002027280	RET. EJE MANDO SELEC.12.20.5. SD RICHIAMO ASSE COMANDO SELETTOR OIL SEAL, SELECTOR SHAFT	SIMMERRING JOINT ANTI-FUITE	1 2 3 4	
08A		00002028770	ARANDELA SEGURO TAMBOR RONDELLA WASHER	SCHEIBE RONDELLE	1 2 3 4	
09A		00H02700251	MUELLE SELECTOR MOLLA SPRING	FEDER RESSORT	1 2 3 4	
10A		00H02703421	CTO. PALANCA CAMBIO ÉLEVA CAMBIO GEARSHIFT ASSY.	GRUPPE GANGSCHALTHEBEL PEDALE DE SELECTEUR	1 2 3 4	

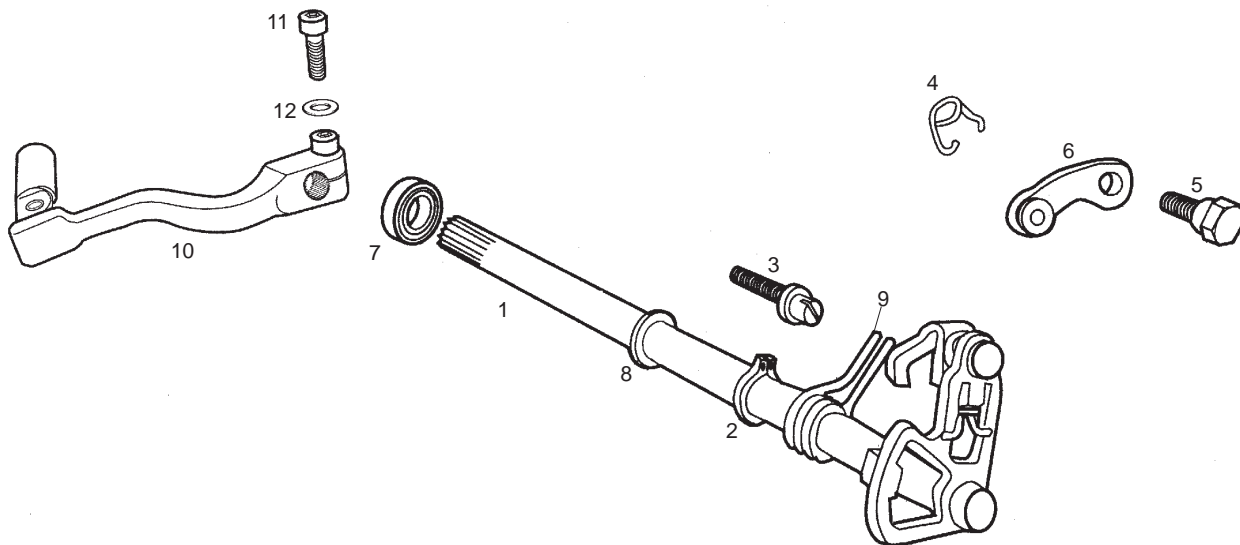

Fig.	Ver.	COD. KOD.	DESCRIPCIÓN DENOMINAZIONE NAME	BEZEICHNUNG DESIGNATION	MOD.	NOTAS NOTES NOTA MITSCHRIFT NOTES
11A		00002062511	TORNILLO C/ALLEN 6M100X25 VITE SCREW	SCHRAUBE VIS	1 2 3 4	
12A		00442060002	ARANDELA MUELLE D6 RONDELLA WASHER	SCHEIBE RONDELLE	1 2 3 4	

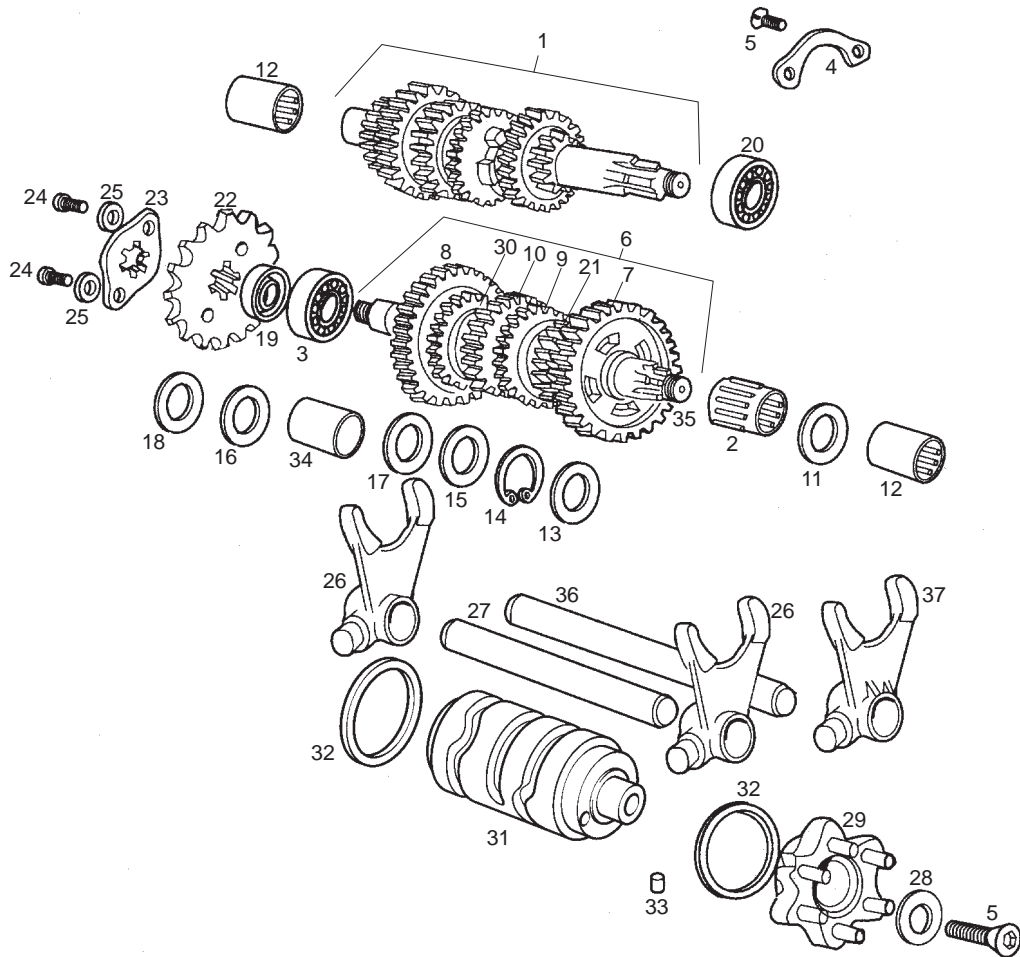

Fig.	Ver.	COD. KOD.	DESCRIPCIÓN DENOMINAZIONE NAME	BEZEICHNUNG DESIGNATION	MOD.	NOTAS NOTES NOTA MITSCHRIFT NOTES
01A		00H02803291	SCTO. EJE PRIMARIO. AGUA. SUBASSE PRIMARIO SEN DRIVE SHAFT.	PRIMARCHSE AXE PRIMAIRE	1 2 3 4	
02A		00D02820101	CORONA AGUJ. PIÑ.2-1A. K14X18X8F CORONA RULLINI PIGNONE .2-1A. K NEEDLE BEARING	BADELLGER ROULEMENT AIGUILLES	1 2 3 4	
03A		00057120300	COJINETE CUSCINETTO BEARING	LAGER COUSSINET	1 2 3 4	
04A		00H02800901	PRECINTO COJINETE EJE PRIM. PIASTRINA CUSCINETTO ASSE PRIM PLATE POSITION BALL BEARINGS	KUGELLEGERPRIMDRACHSE BUTEE DE ROULEMENT	1 2 3 4	
05A		00000013510	TORNILLO AV. ALL.5M80X10 VITE SCREW	SCHRAUBE VIS	1 2 3 4	
06A		00H02807131	CTO. EJE SECUNDARIO.6V ASSE SECONDARIO OUTPUT SHAFT	SEKUNDARACHSE AXE SECONDAIRE MONTE COMPLE	1 2 3 4	
07A		00H02820211	PIÑON SECUNDARIO I Z-34 PIGNONE GEAR	RITZEL PIGNON	1 2 3 4	
08A		00H02801221	PIÑON SECUNDARIO II Z-30 PIGNONE GEAR	RITZEL PIGNON	1 2 3 4	
09A		00H02810231	PIÑON SECUNDARIO III Z-27 PIGNONE GEAR	RITZEL PIGNON	1 2 3 4	
10A		00H02801481	PIÑON SECUNDARIO IV Z-24 PIGNONE GEAR	RITZEL PIGNON	1 2 3 4	
11A		00H02800181	ARANDELA REGLAJE EJE SECUNDARIO RONDELLA WASHER	SCHEIBE RONDELLE	1 2 3 4	

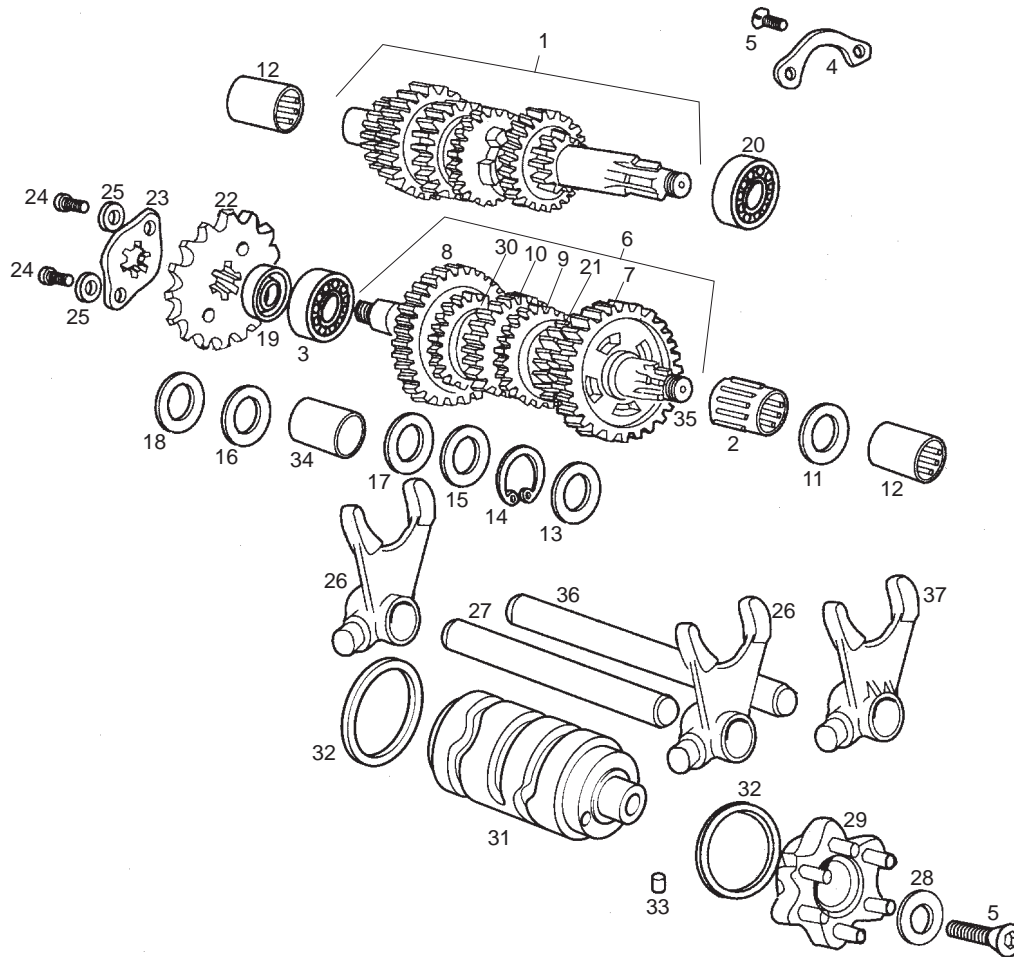

Fig.	Ver.	COD. KOD.	DESCRIPCIÓN DENOMINAZIONE NAME	BEZEICHNUNG DESIGNATION	MOD.	NOTAS NOTES NOTA MITSCHRIFT NOTES
12A		00002028450	CASQUILLO BRONZINA BUSHING	BUCHSE ENTRETOISE	1 2 3 4	
13A		00H02800251	ARANDELA ROZAMTO. PIÑON SECUND. I RONDELLA WASHER	SCHEIBE RONDELLE	1 2 3 4	
14A		00002028550	ANILLO SEGURIDAD EJES D18 ANELLO SICUREZZA CIRCLIP	SICHERHEITSRING ANNEAU SECURITE	1 2 3 4	
15A		00H02800561	ARANDELA PIÑS. SECUND. III/IV RONDELLA WASHER	SCHEIBE RONDELLE	1 2 3 4	
16A		00H02810561	ARANDELA ROZMTO. PIÑ. PRIM.V RONDELLA WASHER	SCHEIBE RONDELLE	1 2 3 4	
17A		00H02820561	ARANDELA ROZAMT. PIÑON SEC. II. RONDELLA WASHER	SCHEIBE RONDELLE	1 2 3 4	
18A		00H02810181	ARANDELA COJINT. EJE SECUNDARIO RONDELLA WASHER	SCHEIBE RONDELLE	1 2 3 4	
19A		00H02800401	RETEN PIÑON SALIDA CAMBIO GIUNTO TENUTA SEAL	DICHTRING JOINT	1 2 3 4	
20A		00058020301	COJINETE CUSCINETTO BEARING	LAGER COUSSINET	1 2 3 4	
21A		00H02810411	PIÑON SECUNDARIO V Z-23 PIGNONE GEAR	RITZEL PIGNON	1 2 3 4	
22A		00F02804371	PIÑON SALIDA CAMBIO Z-13 PIGNONE GEAR	RITZEL PIGNON	1 2 3 4	

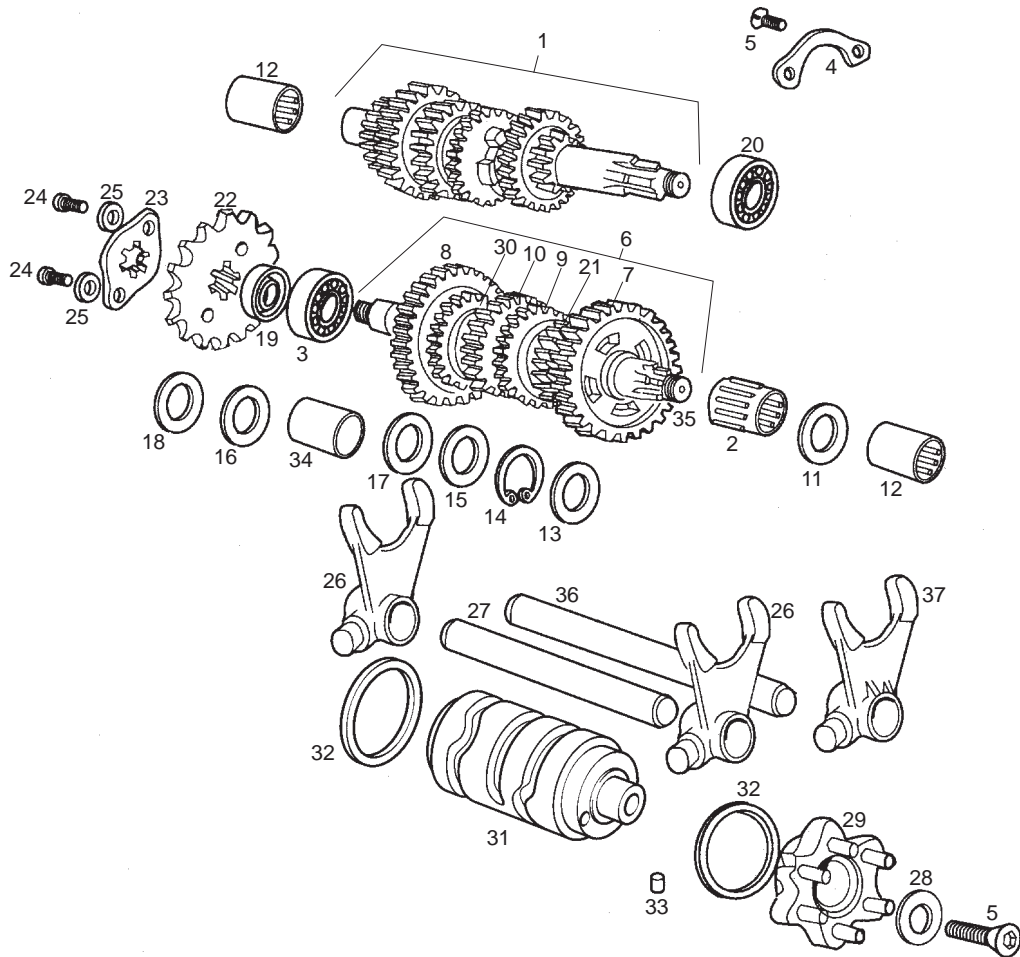

Fig.	Ver.	COD. KOD.	DESCRIPCIÓN DENOMINAZIONE NAME	BEZEICHNUNG DESIGNATION	MOD.	NOTAS NOTES NOTA MITSCHRIFT NOTES
23A		00H02810421	PRECINTO PIÑON SALIDA CAMBIO PIASTRINA PIGNONE USCITA CAMBI LOCKWASHER, COUNTERSHAFT SPROK	RITZEL RONDELLE DE SECURITE SBV.	1 2 3 4	
24A		00000004510	TORNILLO C/ALLEN 5M80X10NEGRO VITE SCREW	SCHRAUBE VIS	1 2 3 4	
25A		00000034050	ARANDELA EST. INT. D5 RONDELLA WASHER	SCHEIBE RONDELLE	1 2 3 4	
26A		00H02820651	HORQ. SECUNDARIA.4-6V. FORCELLA SECONDARIA FORK OUTPUT	SHALTGABEL FOURCHETTE	1 2 3 4	
27A		00H02800881	EJE HORQ. SECUNDARIA ASSE FORCELLA SECONDARIA 74/80 SECONDARY FORK SHAFT	GABEL SEKUNDARACHSE AXE	1 2 3 4	
28A		00H02800801	ARANDELA PIÑ. CONTR/MAND. TAMBOR RONDELLA WASHER	SCHEIBE RONDELLE	1 2 3 4	
29A		00H02810631	CABEZA MANDO TAMBOR TESTA COMANDO TAMBORO 74CC. DRUM HEAD	ESTEUERKOPF TETE TAMBOR SELECTEUR	1 2 3 4	
30A		00H02810741	PIÑON SECUNDARIO VI Z-22 PIGNONE GEAR	RITZEL PIGNON	1 2 3 4	
31A		00H02802861	TAMBOR DISTRIBUIDOR TAMBORO DISTRIBUTORE SHIFT DRUM	VERTEILERTRONNDEL BARILLET	1 2 3 4	
32A		00D04000291	ARANDELA TAMBOR DISTRIBD. RONDELLA WASHER	SCHEIBE RONDELLE	1 2 3 4	
33A		00000066060	RODILLO.4X6. RULLO ROLLER	WALZE ROULEAU	1 2 3 4	

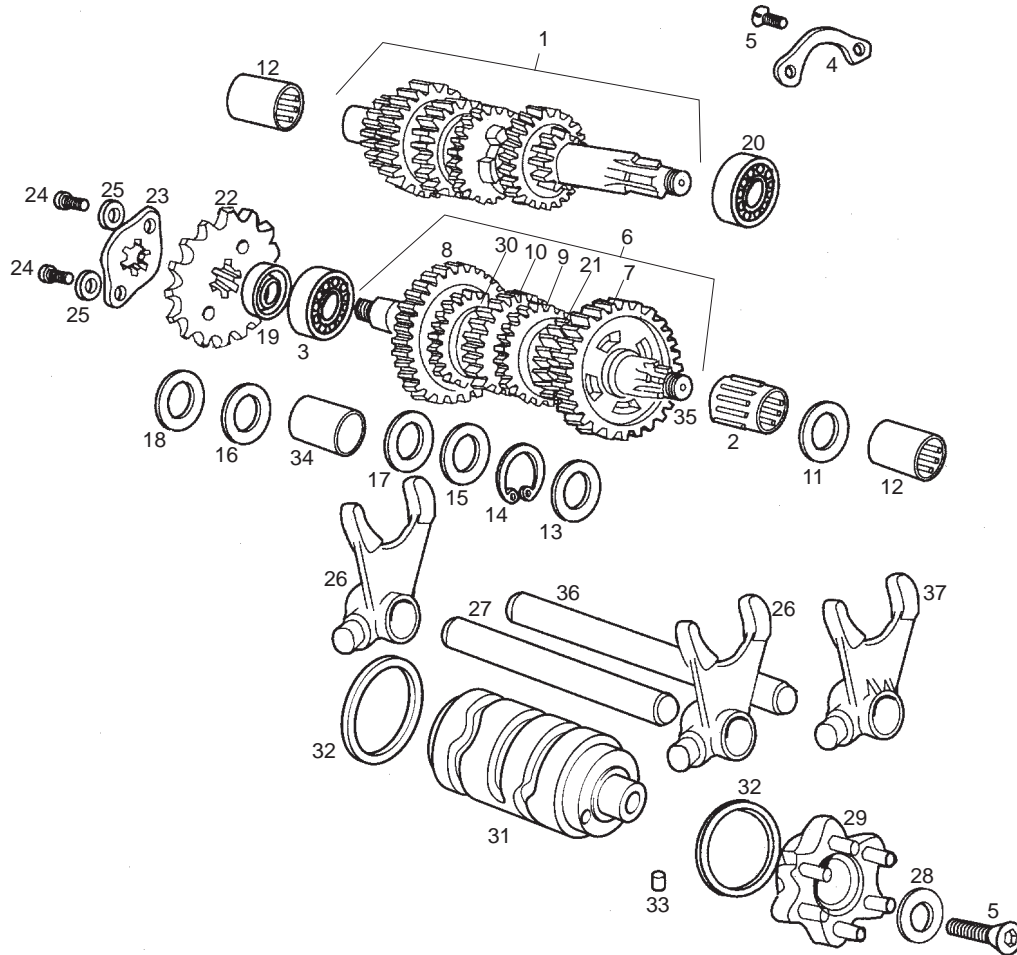

Fig.	Ver.	COD. KOD.	DESCRIPCIÓN DENOMINAZIONE NAME	BEZEICHNUNG DESIGNATION	MOD.	NOTAS NOTES NOTA MITSCHRIFT NOTES
34A		00H02800241	CASQUILLO BRONZINA BUSHING	BUCHSE ENTRETOISE	1 2 3 4	
35A		00H02803161	EJE SECUNDARIO ASSE SHAFT	ACHSE AXE	1 2 3 4	
36A		00H02800891	EJE HORQ. PRIMARIA ASSE SHAFT	ACHSE AXE	1 2 3 4	
37A		00H02820661	HORQ. PRIMARIA.V-VI. FORCELLA PRIMARIA V-VI FORK OUTPUT	SHALTGABEL FOURCHETTE	1 2 3 4	

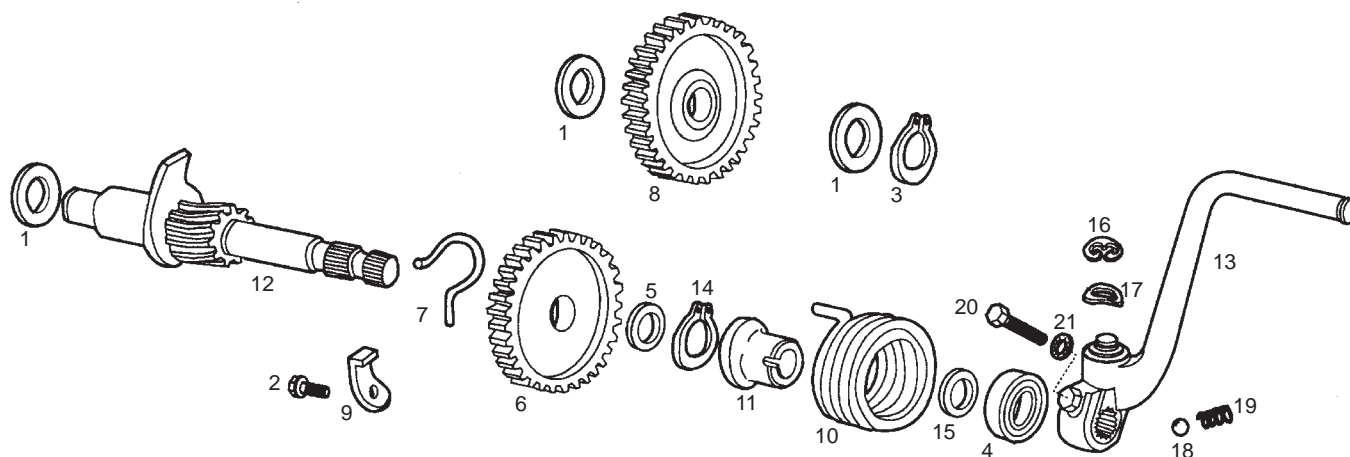

Fig.	Ver.	COD. KOD.	DESCRIPCIÓN DENOMINAZIONE NAME	BEZEICHNUNG DESIGNATION	MOD.	NOTAS NOTES NOTA MITSCHRIFT NOTES
01A		00002028770	ARANDELA SEGURO TAMBOR RONDELLA WASHER	SCHEIBE RONDELLE	1 2 3 4	
02A		00H02900761	TORNILLO FIJ. TOPE ARRQ.6X10 VITE SCREW	SCHRAUBE VIS	1 2 3 4	
03A		00000047111	ANILLO SEGURIDAD EJES D11 ANELLO SICUREZZA CIRCLIP	SICHERHEITSRING ANNEAU SECURITE	1 2 3 4	
04A		00D02910131	RETEN EJE ARRANQUE GIUNTO TENUTA SEAL	DICHTRING JOINT	1 2 3 4	
05A		00005529290	ARANDELA TOPE PIÑ. ARRQ. RONDELLA WASHER	SCHEIBE RONDELLE	1 2 3 4	
06A		00H02900091	PIÑON ARRANQUE Z-29 PIGNONE AVVIAMENTO Z-29 KICKSTARTER GEAR Z-29	ANLAUFTRITZEL ROUE DE MISE EN MARCHE Z-29	1 2 3 4	
07A		00H02900281	MUELLE PIÑON ARRANQUE MOLLA SPRING	FEDER RESSORT	1 2 3 4	
08A		00H02901441	PIÑON INTERMED. ARRQ. PIGNONE INTERMEDIO AVVIAMENTO DRIVING GEAR	ANLAUF-ZWISCHENRITZEL ROUE INTERMEDIAIRE	1 2 3 4	
09A		00H02901551	REFZO. TOPE ARRQ. RINFORZO FERMO AVVIAMENTO KICKSTARTER LEVER STOP	VERSTARUNG F. ANSCHULAG BUTEE PEDALE DE KICK	1 2 3 4	
10A		00H02900041	MUELLE ARRANQUE MOLLA SPRING	FEDER RESSORT	1 2 3 4	
11A		00H02900271	CAZLTA. GUIA MUELLE ARRQ. SCODELLINO GUIDA MOLLA AVVIAME SPRING GUIDE	FUHRUNGSPFANE RAMPE DE KICK	1 2 3 4	



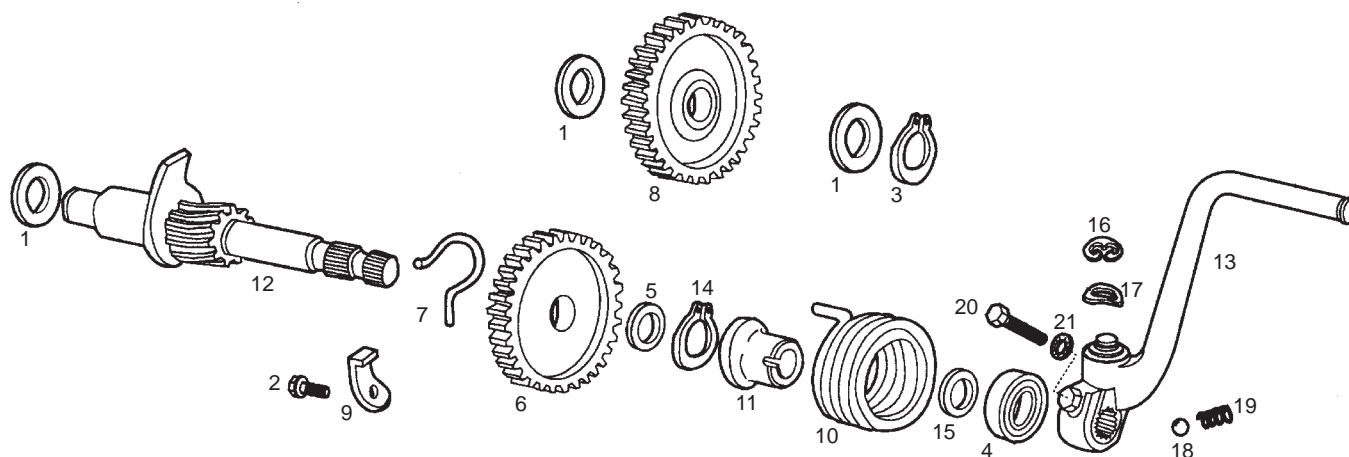

Fig.	Ver.	COD. KOD.	DESCRIPCIÓN DENOMINAZIONE NAME	BEZEICHNUNG DESIGNATION	MOD.	NOTAS NOTES NOTA MITSCHRIFT NOTES
12A		00H02900011	SCTO. EJE ARRANQUE, SUBASSE AVVIAMENTO S KICKSTARTER SHAFT	ANLAUFACHSE ARBRE DE KICK	1 2 3 4	
13A		00H02902252	CTO. PALANCA ARRANQUE LEVA AVVIAMENTO FENI KICKSTARTER LEVER	KICKSTARTER LEVIER DE KICK	1 2 3 4	
14A		00000047122	ANILLO SEGURIDAD EJES D22 ANELLO SICUREZZA CIRCLIP	SICHERHEITSRING ANNEAU SECURITE	1 2 3 4	
15A		00002029050	ARANDELA TOPE ARRQ.4-6V. RONDELLA WASHER	SCHEIBE RONDELLE	1 2 3 4	
16A		00047030900	ANILLO SEGURIDAD EJES D9 ANELLO SICUREZZA CIRCLIP	SICHERHEITSRING ANNEAU SECURITE	1 2 3 4	
17A		00000036100	ARANDELA MUELLE AB. D10,5. RONDELLA WASHER	SCHEIBE RONDELLE	1 2 3 4	
18A		00000061040	BOLA. D4,76. PALLA D4,76 BALL, D4,76	KUGEL D4,76 BILLE DIAMETRE D4,76.	1 2 3 4	
19A		00003127200	MUELLE GATILLOS ANTORCHA MOLLA SPRING	FEDER RESSORT	1 2 3 4	
20A		00004162500	TORNILLO C/ALLEN.6M100X25. NG VITE SCREW	SCHRAUBE VIS	1 2 3 4	
21A		00037000600	ARANDELA CONICA SEG. D6 RONDELLA WASHER	SCHEIBE RONDELLE	1 2 3 4	

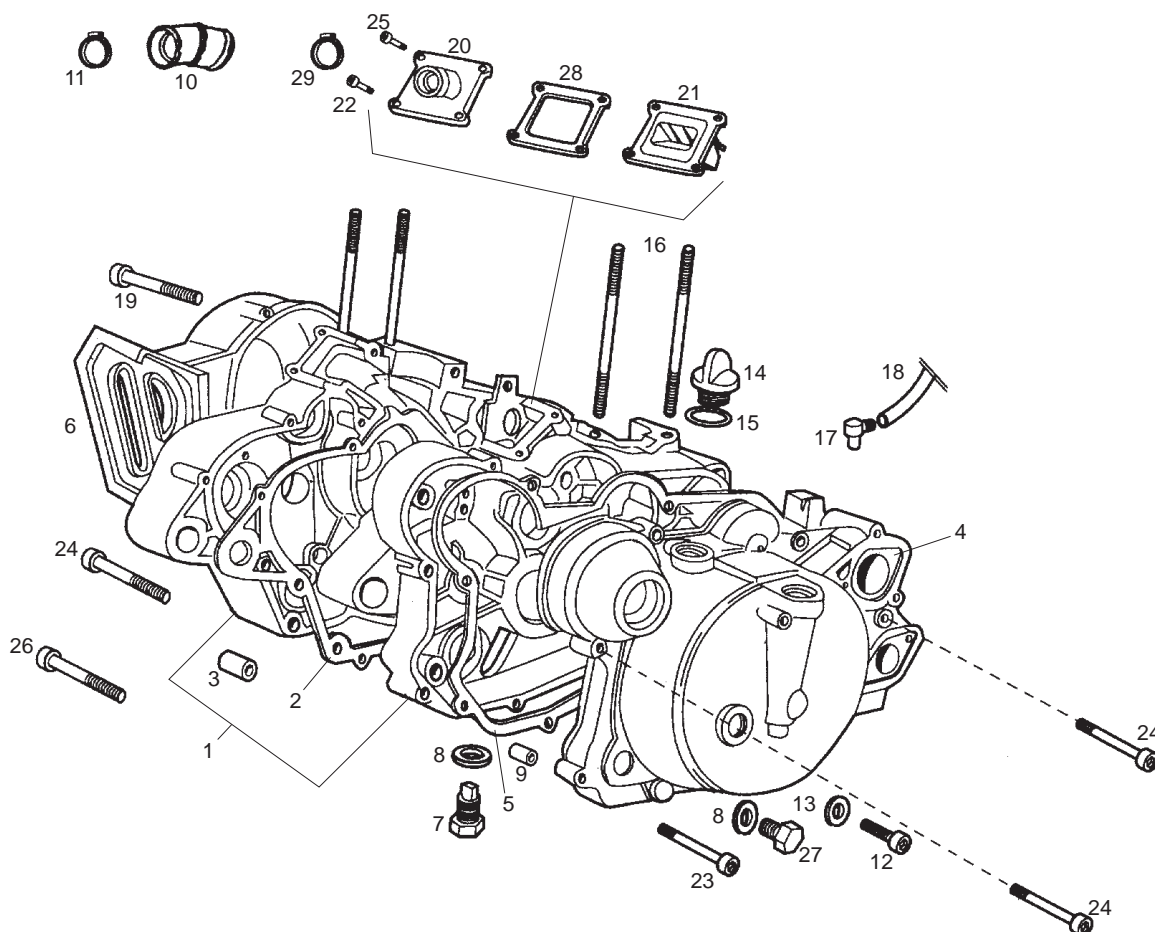

Fig.	Ver.	COD. KOD.	DESCRIPCIÓN DENOMINAZIONE NAME	BEZEICHNUNG DESIGNATION	MOD.	NOTAS NOTES NOTA MITSCHRIFT NOTES
01A		00H03003634	CTO. CARTER CARTERS 50 C. C. CRANKCASE ASSEMBLY	MOTORGEHAUSE ENSEMBLE DES CARTERS MOTEUR	1 2 3 4	
02A		00H03000031	JUNTA CARTERS.50CC. GUARNIZIONE GASKET	DICHTUNG JOINT	1 2 3 4	
03A		00H03010361	SEPARAD. SILENT. DT. CARTER SEPARATORE SILENTBLOCKANTERIO BUSHING	FUHRUNGSBUCHSE GABELSCHENK ENTRETOISE	1 2 3 4	
04A		00H03007882	TAPA CARTER DERECHA SUBC. COP. CARTER DES. CRANKCASE COVER	KUPLINGSDECKEL CARTER DIEMBRAYAGE	1 2 3 4	
05A		00H03000141	JUNTA TAPA CARTER DR.74/80CC. GUARNIZIONE GASKET	DICHTUNG JOINT	1 2 3 4	
06A		00H03005241	TAPA CARTER IZQUIERDA COPERCHIO COVER	DECKEL COUVERCLE	1 2 3 4	
07A		00A03001422	CTO. TORNILLO VACIADO ACEITE VITE SCREW	SCHRAUBE VIS	1 2 3 4	
08A		00A03000121	ARANDELAVACDO. ACTE. RONDELLA WASHER	SCHEIBE RONDELLE	1 2 3 4	
09A		00002030020	PASADOR UNION CARTER CHIAVISTELLO PIN	STIFT GOUDILLE	1 2 3 4	
10A		00H02502891	CASQUILLO BRONZINA BUSHING	BUCHSE ENTRETOISE	1 2 3 4	
11A		00H02501491	BRIDA BRIGLIA BRIDLE	ZÜGEL BRIDE	1 2 3 4	

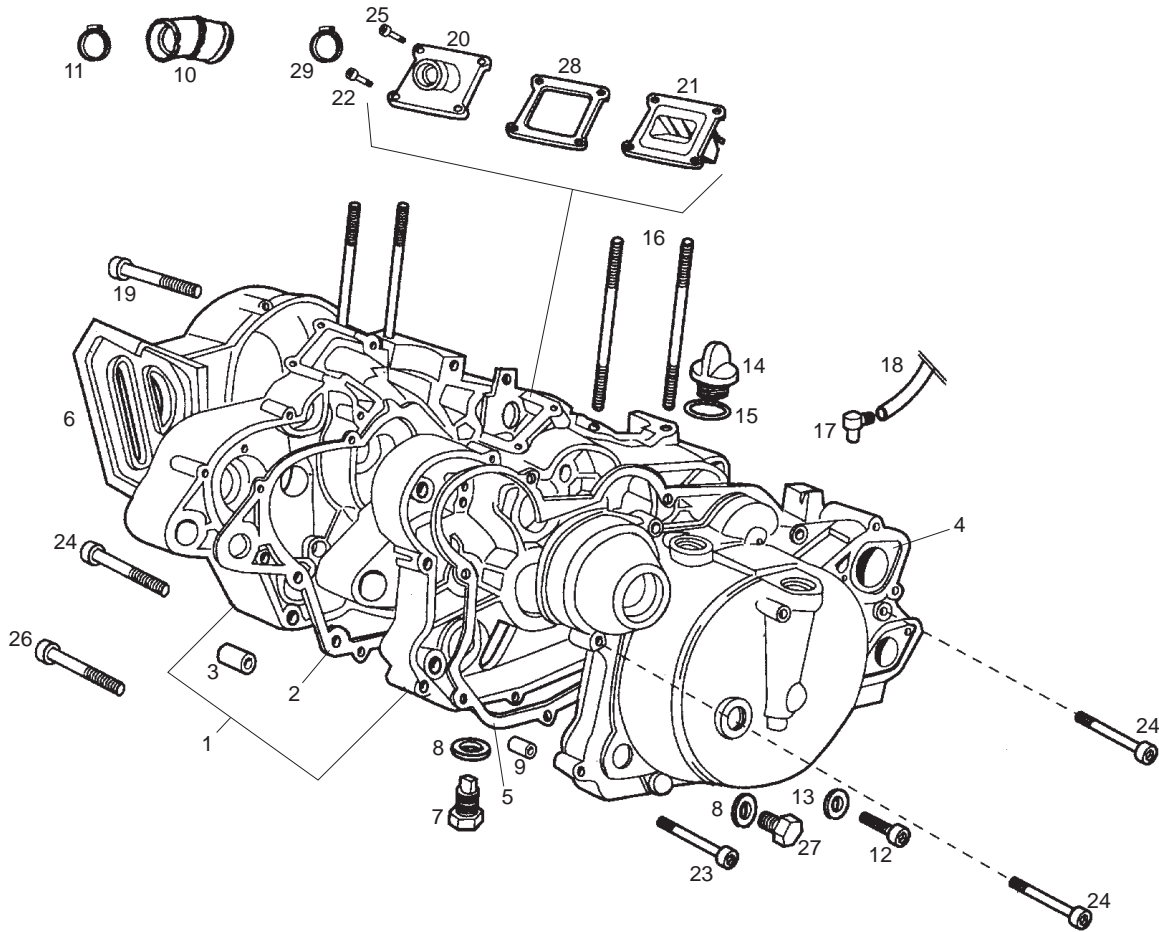

Fig.	Ver.	COD. KOD.	DESCRIPCIÓN DENOMINAZIONE NAME	BEZEICHNUNG DESIGNATION	MOD.	NOTAS NOTES NOTA MITSCHRIFT NOTES
12A		00002061011	TORNILLO C/ALLEN.6M100X10 VITE SCREW	SCHRAUBE VIS	1 2 3 4	
13A		00003102280	ARANDELA NIVEL ACEITE. D6 RONDELLA WASHER	SCHEIBE RONDELLE	1 2 3 4	
14A		00H03000081	TORNILLO LLENADO ACEITE VITE SCREW	SCHRAUBE VIS	1 2 3 4	
15A		00001130370	ANILLO TORICO ANELLO TORICO OL WASHER SEALING	O-RING JOINT	1 2 3 4	
16A		00003130050	ESPARRG. FIJ. CILINDRO. ANTORCHA. BULLONE FISSAGGIO CILINDRO TOR STUD CYLINDER	STEBBOLZEN GOUJON DE FIXE CYLINDRE	1 2 3 4	
17A		00005530600	RACORD SALIDA GASES CART.4-6V. RACCORDI USCITA GAS CARTER . CRANKCASE VENT RACCORD	AUSGANGSSTUTZEN RACCORD DE SORTIE GAZ CARTE	1 2 3 4	
18A		00H03700461	TUBO RESPIRAD. DEPOSITO ACEITE TUBO TUBE	ROHR TUYAU	1 2 3 4	
19A		00G03900821	TORNILLO C/ALLEN.6M100X30 VITE SCREW	SCHRAUBE VIS	1 2 3 4	
20A		00H02507061	BOQUILLA CARBURANTE ATTACCO CARBURATORE INTAKE MANIFOLD,	ANSAUGSTUTZEN ENSEMB. PIPE DIADMISSION	1 2 3 4	
21A		00H02510641	CTO. CAJA LAM. ADM.74/80CC.2598- CASSA LAMINA AMMISSI INLET BOX	MEMBRANE BOITE A CLAPETS	1 2 3 4	
22A		00G03000211	TORNILLO C/ALLEN.6M100X25 VITE SCREW	SCHRAUBE VIS	1 2 3 4	

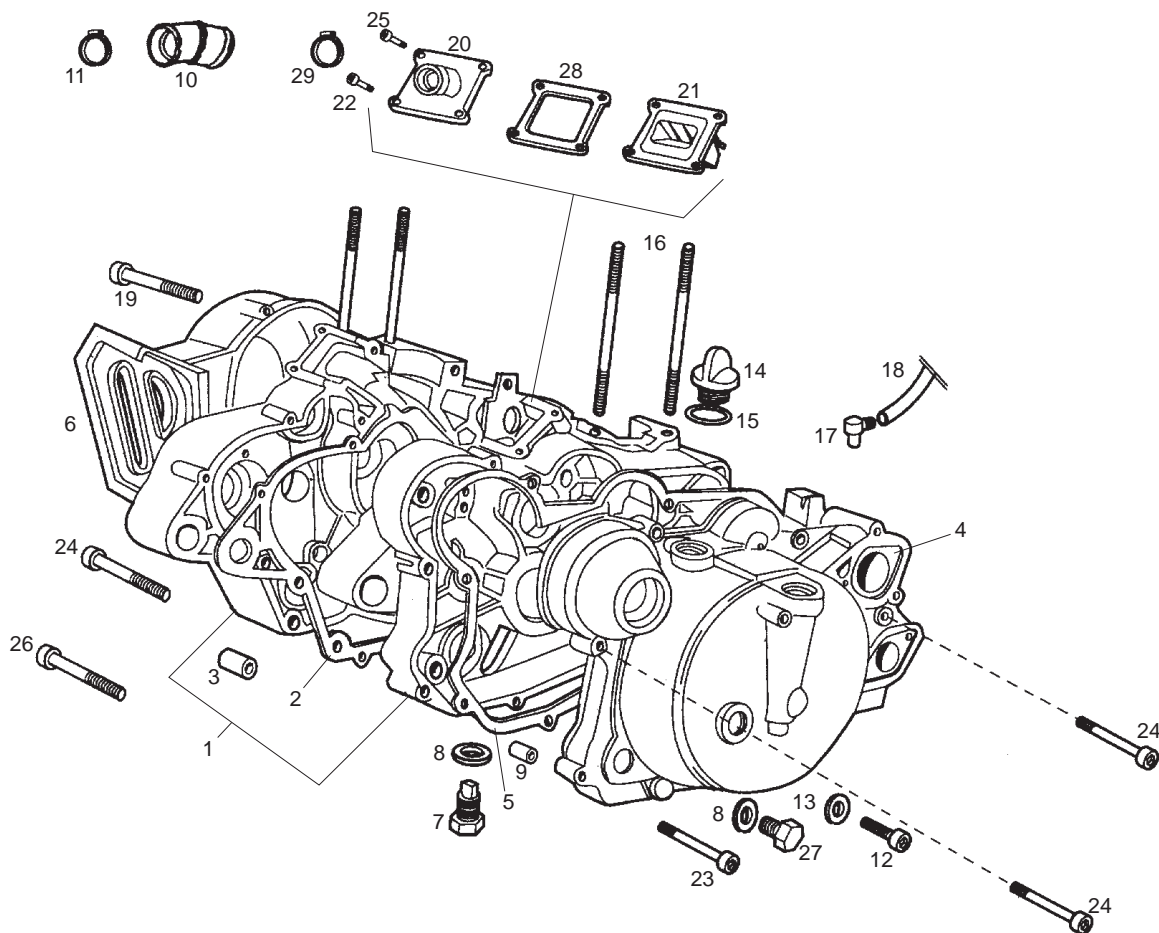

Fig.	Ver.	COD. KOD.	DESCRIPCIÓN DENOMINAZIONE NAME	BEZEICHNUNG DESIGNATION	MOD.	NOTAS NOTES NOTA MITSCHRIFT NOTES
23A		00G03001091	TORNILLO C/ALLEN.6M100X35 VITE SCREW	SCHRAUBE VIS	1 2 3 4	
24A		00G03002091	TORNILLO C/ALLEN.6M100X40 VITE SCREW	SCHRAUBE VIS	1 2 3 4	
25A		828152	TORNILLO VITE SCREW	SCHRAUBE VIS	1 2 3 4	
26A		00H03000091	TORNILLO C/ALLEN.6M100X50 VITE SCREW	SCHRAUBE VIS	1 2 3 4	
27A		00A03000132	TORNILLO VACIADO ACEITE VITE SCREW	SCHRAUBE VIS	1 2 3 4	
28A		00H02500811	JUNTA SOPTE.VALVULA ADMIS.74CC GUARNIZIONE GASKET	DICHTUNG JOINT	1 2 3 4	
29A		00H02500491	BRIDA BRIGLIA BRIDLE	ZÜGEL BRIDE	1 2 3 4	

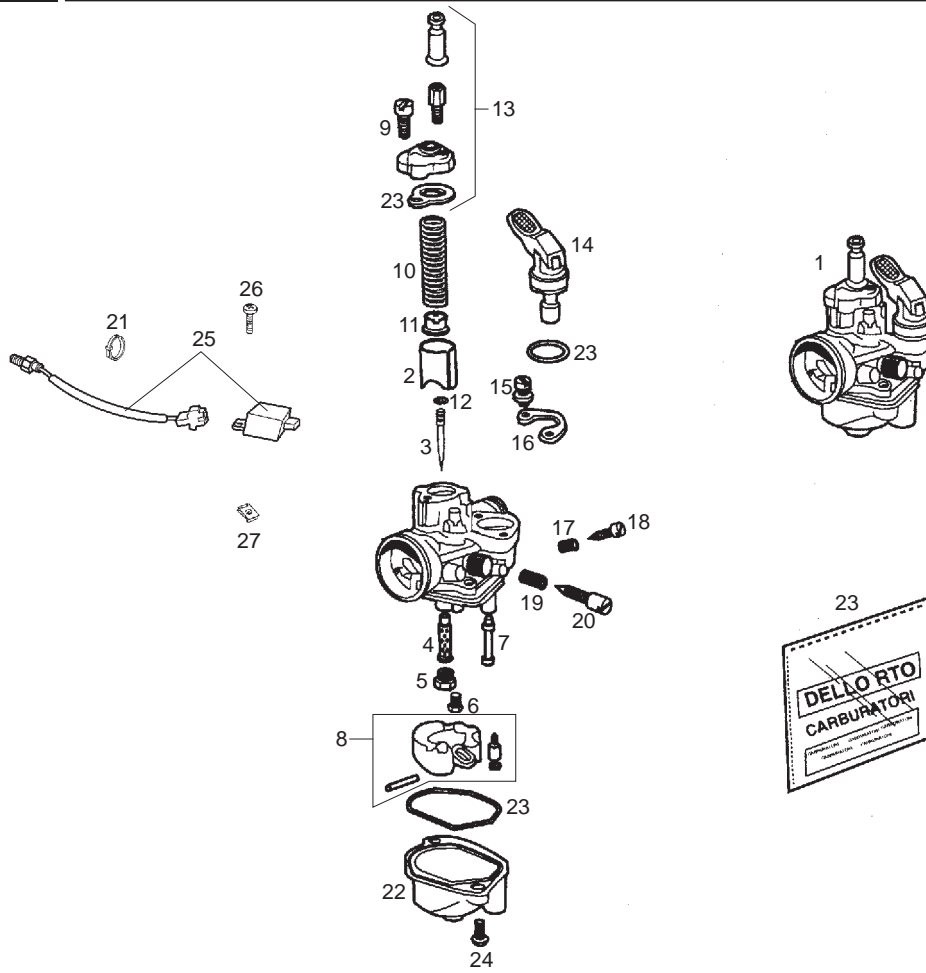

Fig.	Ver.	COD. KOD.	DESCRIPCIÓN DENOMINAZIONE NAME	BEZEICHNUNG DESIGNATION	MOD.	NOTAS NOTES NOTA MITSCHRIFT NOTES
01A		00H03243011	CTO. CARBURADOR CARBURATORE CARBURETOR	VERGASER KOMPL ENSEMBLE CARBURATEUR	1 2 3 4	
02A		00F03201211	R-COMPUERTA GAS R-VALVOLA GAS SLIDE	GASSCHIEBER BOISSEAU	1 2 3 4	
03A		00H03214431	AGUJA PULVERIZADORA R-SPILLO SPRUZZATORE NEEDLE	DUESENNADELUSE AIGUILLE PULVERIZ.	1 2 3 4	
04A		00H03204421	R-PULVERIZADOR POLVERIZZATORE NEEDLE JET	ZERSTAUBERDUSE PULVERISATEUR	1 2 3 4	
05A		00F03200031	R-SURTIDOR MAX. 62 R-GETTO MASSIMO MAIN JET	HAUPT DUSE GICLEUR PRINCIPAL	1 2 3 4	
06A		00H04107181	R-SURTIDOR MIN. 30 R-GETTO MINIMO JET MIN	DUESE MIN. R-GICLEUR MINIMUM.	1 2 3 4	
07A		00H03203481	R-SURTIDOR ENTRADA AIRE R-GETTO INGRESSO IDLE JET	LUFTEINLASS-DUSE R-GICLEUR D'ENTRE D'AIR	1 2 3 4	
08A		00H03202281	R-KIT FLOTADOR R-GALLEGGIANTE FLOAT	SCHWIMMER R-FLOTTEUR	1 2 3 4	
09A		00G03200061	R-TORNILLO FIJ. TAPA CAMARA MEZCLA VITE SCREW	SCHRAUBE VIS	1 2 3 4	
10A		00G03201071	R-MUELLE VALVULA GAS R-MOLLA VALVOLA GAS VAMOS AV THROOTLE VALVE RETURN	FEDER FUR GASVENTIL R-RESSORT VALVE ESS.	1 2 3 4	
11A		00G03200511	R-CASQUILLO AGUJA PULVERIZADORA R-GHIERA SPILLO SPRUZZATORE NEEDLE BUSHING	BUCHSE DUESENNADEL R-DOUILLE AIGUI. PULVERZ.	1 2 3 4	

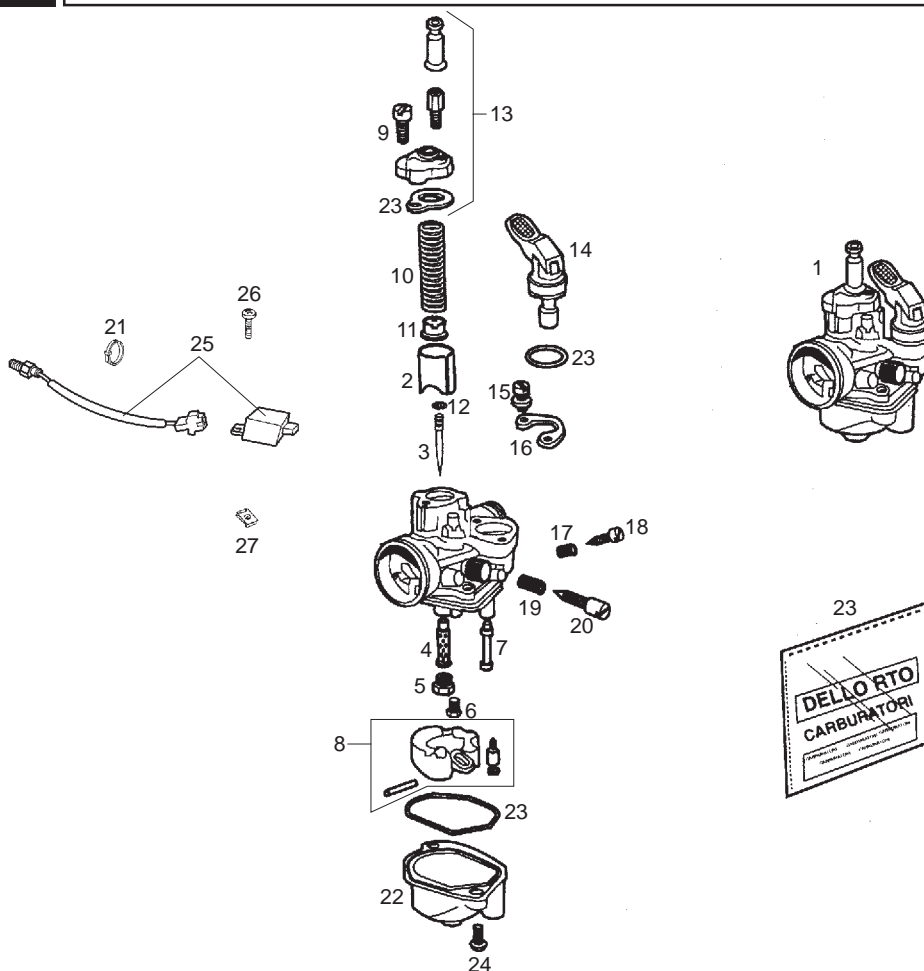

Fig.	Ver.	COD. KOD.	DESCRIPCIÓN DENOMINAZIONE NAME	BEZEICHNUNG DESIGNATION	MOD.	NOTAS NOTES NOTA MITSCHRIFT NOTES
12A		00G03201371	R-PINZA AGUJA PULVERIZADORA R-MORSA SPILLO SPRUZZATORE NEEDLE CIRCLIP	KLAMMER DUESENNADEL R-PINCE AIGUI.PULVERZ.	1 2 3 4	
13A		00H03204231	R-TAPA CAMARA MEZCLA R-COPERCHIO CAMARA MISCELA SE COVER CARBURETOR TOP	MISCHRAUMDECKEL COUVERCLE CARBURATEUR	1 2 3 4	
14A		00H03203711	R-CTO.STARTER R-STARTER CHOCKE LOCK	STARTERVENTIL VANNE DU STARTER MANUEL	1 2 3 4	
15A		00G03200541	R-TORNILLO FIJ.STARTER VITE SCREW	SCHRAUBE VIS	1 2 3 4	
16A		00G03200551	R-PRECINTO FIJACION STARTER SIGILLO SEAL	VERSIEGELUNG ATTACHE	1 2 3 4	
17A		00G03200721	R-MUELLE REGULACION AIRE MIN. MOLLA SPRING	FEDER RESSORT	1 2 3 4	
18A		00G03200731	R-TORNILLO REG.AIRE MIN. VITE SCREW	SCHRAUBE VIS	1 2 3 4	
19A		00G03200101	R-MUELLE REG.VALVULA GAS MOLLA SPRING	FEDER RESSORT	1 2 3 4	
20A		00G04102131	R-TORNILLO REGULACION VALVULA GAS VITE SCREW	SCHRAUBE VIS	1 2 3 4	
21A		00A00900531	BRIDA BRIGLIA BRIDLE	ZÜGEL BRIDE	2 4	
22A		00H03201201	R-VASO GASOLINA R-VASCHETTA BENZZINA FLOAT BOWL SEET	SCHWIMMERKAMMER CUVE INFERIEURE CARBUR.	1 2 3 4	

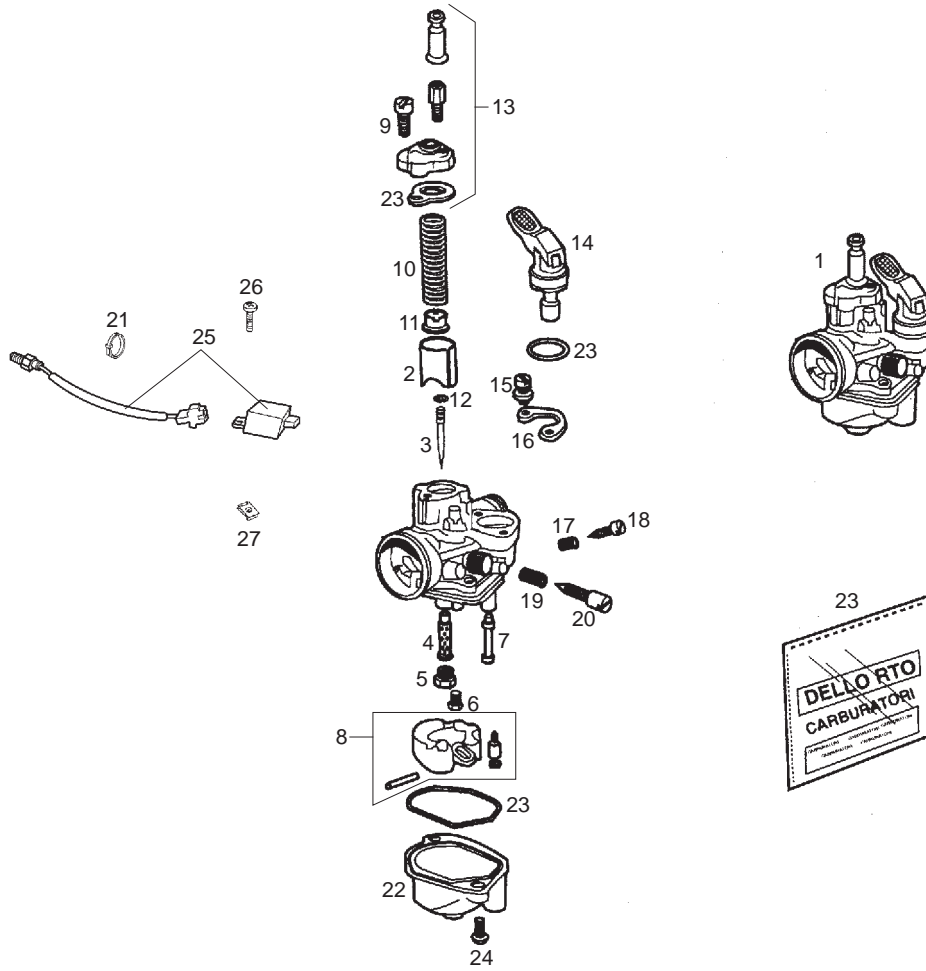

Fig.	Ver.	COD. KOD.	DESCRIPCIÓN DENOMINAZIONE NAME	BEZEICHNUNG DESIGNATION	MOD.	NOTAS NOTES NOTA MITSCHRIFT NOTES
23A		00G04100771	R-CTO.JUNTAS CARBURADOR R-GUARNIZIONE CARBU. CARBURETOR GASKET SET	DICHTUNGSATZ KOMPL. VERGAS R-ENS. JOINTS CARBUR.	1 2 3 4	
24A		00G03201091	R-TORNILLO FIJ.VASO GASOLINA VITE SCREW	SCHRAUBE VIS	1 2 3 4	
25A		00H06001151	CTO KIT CALENTADOR CARBURADOR KIT RISCALDAMENTO KIT CARBURETTOR HEATER	KABELBAUN FUR HEIZUNG VERG KIT QUI CHAUFFE CARBURATEUR	2 4	
26A		00D05900031	TORNILLO 6M100X10 VITE SCREW	SCHRAUBE VIS	2 4	
27A		00D01501371	TUERCA FIJACION D6 DADO NUT	MUTTER ECROU	2 4	



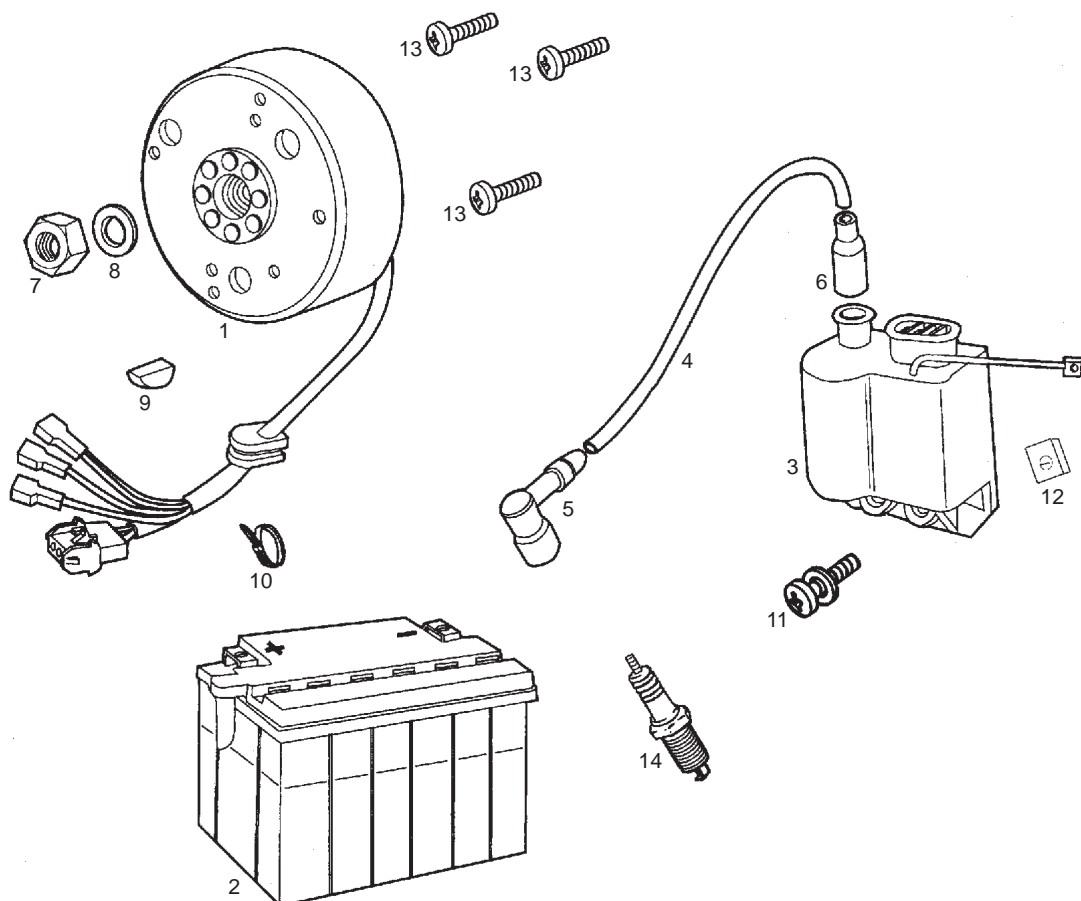

Fig.	Ver.	COD. KOD.	DESCRIPCIÓN DENOMINAZIONE NAME	BEZEICHNUNG DESIGNATION	MOD.	NOTAS NOTES NOTA MITSCHRIFT NOTES
01A		00H03311011	CTO. VOLANTE ELECTRONICO VOLANO ELETTRONICO MAGNETO ASSEMBLY	LICHTMASCHINE KOMPL. VOLANT MAGNETIQUE	1 2 3 4	
02A		00G03301401	BATERIA 12V BATTERIA BATTERY	BATTERIE BATTERIE	1 2 3 4	
03A		00H03330171	CTO. CONVERSOR ELECTR. COVERTITORE ELETTRON COIL, PRIMARY IGNITION	ZUNDSPULE BOBINE AUTE TENSION	1 2 3 4	
04A		00F03310741	CABLE BOBINA. START. A. E. CAVO BOBINA START. A. E. CABLE COIL PRIMARY IGNITION	ZUNDSPULENKABEL CABLE	1 2 3 4	
05A		00G03301271	CTO. PIPA BUJIA (MTA.) PIPETA CANDELA COVER, SPARK PLUG	ZUNDKERZENSTECRER PIPE DE BOUGIE	1 2 3 4	
06A		00F03300731	CAPUCHON CABLE BOBINA SCO-50. CAPPuccio CAVO BOBINA SCO-50. COIL CABLE RUBBER PROTECTOR	KAPPE CAPUCHON	1 2 3 4	
07A		00H03300221	TUERCA FIJ. VOLTE. MAGN. DADO NUT	MUTTER ECROU	1 2 3 4	
08A		00F03300241	ARANDELA FIJ. VOLTE. MAGN. SCO. DCT. RONDELLA WASHER	SCHEIBE RONDELLE	1 2 3 4	
09A		00003133230	CHAVETA VOLTE. MAGN. P. REC. MCH. SPINA VOLANO MAGNETICO . P. REC. KEY, FLYWHEEL	KEIL CLAVETTE VOLANT MAGNETIQUE	1 2 3 4	
10A		00F00900531	BRIDA BRIGLIA BRIDLE	ZÜGEL BRIDE	1 2 3 4	
11A		00G06800021	SCTO. TORNILLO 6M100X20 VITE SCREW	SCHRAUBE VIS	1 2 3 4	

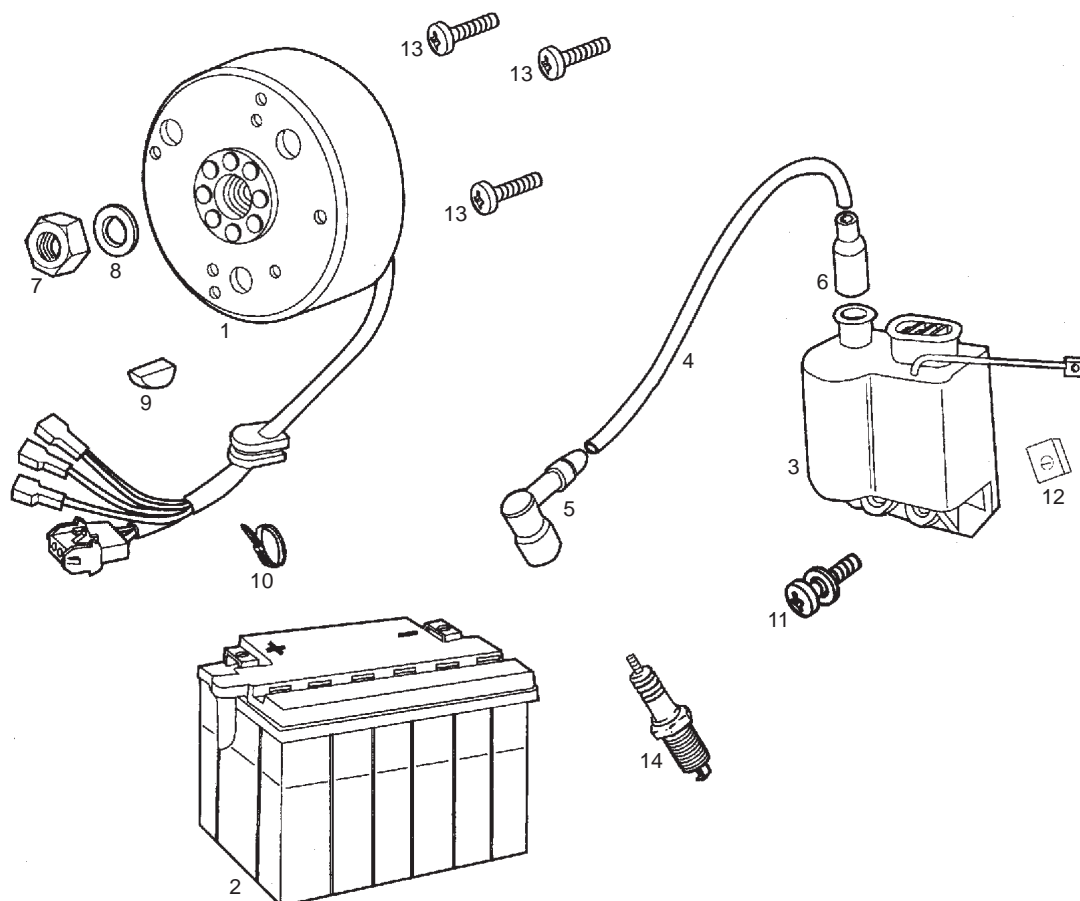

Fig.	Ver.	COD. KOD.	DESCRIPCIÓN DENOMINAZIONE NAME	BEZEICHNUNG DESIGNATION	MOD.	NOTAS NOTES NOTA MITSCHRIFT NOTES
12A		00D01501371	TUERCA FIJ. CUBRECADENA DADO NUT	MUTTER ECROU	1 2 3 4	
13A		00003133260	TORNILLO FIJACION 5M80X10 VITE SCREW	SCHRAUBE VIS	1 2 3 4	
14A		00H03301211	BUJIA CANDELA SPARK PLUG	KERZE BOUGIE	1 2 3 4	

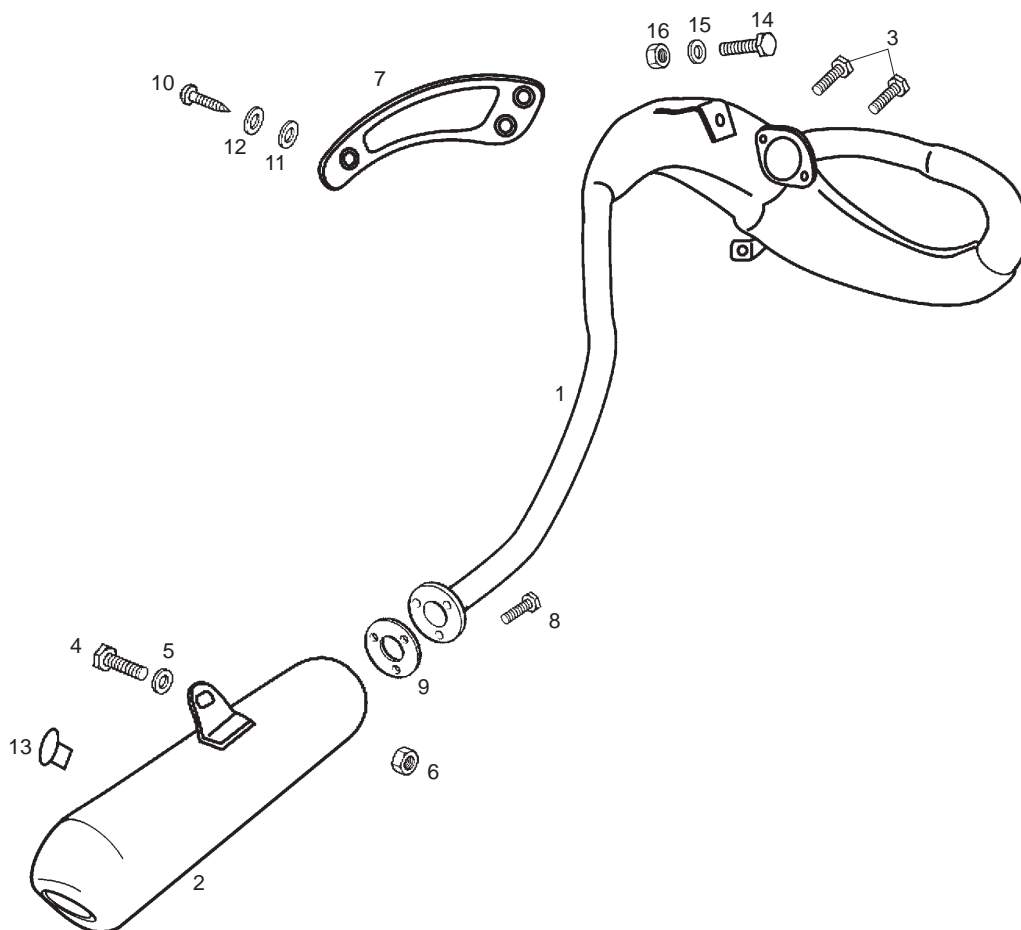

Fig.	Ver.	COD. KOD.	DESCRIPCIÓN DENOMINAZIONE NAME	BEZEICHUNG DESIGNATION	MOD.	NOTAS NOTES NOTA MITSCHRIFT NOTES
01A		00H03450081	SCTO. TUBO ESC-SIL. SUBCOMP. TUBO SCAPP-SIL. EXHAUST PIPE AND MUFFLER	AUSPUFF ENSEMBLE TUBE DIECHAPPEMENT	1 2 3 4	
02A		00H03431411	SCTO. SORDINA SUBCOMP. SORD. EXHAUST TANK	SCHALLDAMPFER SILENCIEUX DIECHAPPEMENT	1 2 3 4	
03A		00002062011	TORNILLO C/ALLEN.6M100X20 VITE SCREW	SCHRAUBE VIS	1 2 3 4	
04A		00012081621	TORNILLO C/EXAG.8M125X16 Zn B VITE SCREW	SCHRAUBE VIS	1 2 3 4	
05A		00402080001	ARANDELA D.8 Zn.B RONDELLA WASHER	SCHEIBE RONDELLE	1 2 3 4	
06A		00023108000	TUERCA AUTOBLOC. 8M125 ZnB DADO NUT	MUTTER ECROU	1 2 3 4	
07A		00H01810391	PROTECTOR SILENCIADOR PROTEZIONE SILENZIATORE SILENCER SHIELD	SCHALLDAEMPERSCHUTZ PROTECT. SIL.	1 2 3 4	
08A		00D05910081	SCTO.TORBILLO 6M100X16 VITE FISSAGGIO SCREW	SCHRAUBE VIS	1 2 3 4	
09A		00H03404321	JUNTA GUARNIZIONE GASKET	DICHTUNG JOINT	1 2 3 4	
10A		00000012415	TORNILLO VITE SCREW	SCHRAUBE VIS	1 2 3 4	
11A		00F04201361	ARANDELA RONDELLA WASHER	SCHEIBE RONDELLE	1 2 3 4	

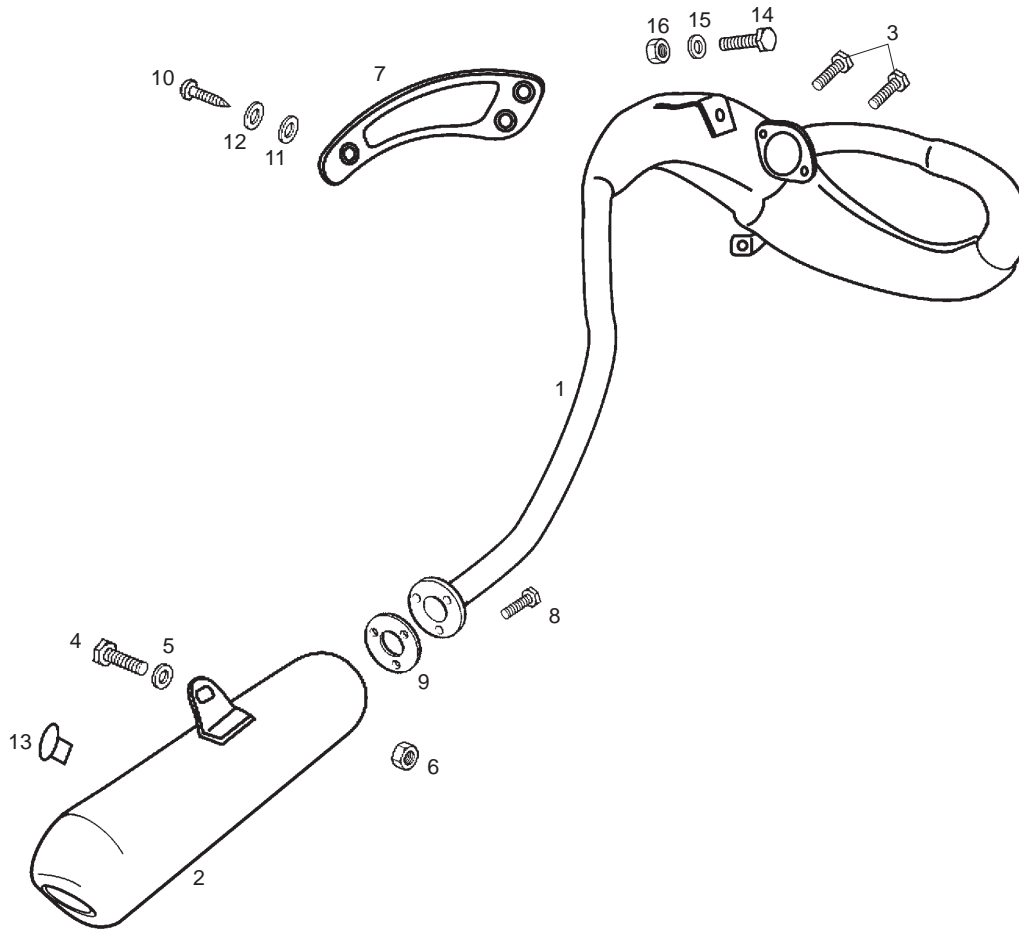

Fig.	Ver.	COD. KOD.	DESCRIPCIÓN DENOMINAZIONE NAME	BEZEICHNUNG DESIGNATION	MOD.	NOTAS NOTES NOTA MITSCHRIFT NOTES
12A		00D02600631	ARANDELA RONDELLA WASHER	SCHEIBE RONDELLE	1 2 3 4	
13A		00G01500951	TOPE GOMA APPOGGIO ZAMPA CAVALLETO SIDE STAND REST	GUMMISTOPPEL APPUI BEQUILLE LATERALE	1 2 3 4	
14A		00012081621	TORNILLO 8M125X16 Zn.B VITE SCREW	SCHRAUBE VIS	1 2 3 4	
15A		00402080001	ARANDELA D8 A Zn.B RONDELLA WASHER	SCHEIBE RONDELLE	1 2 3 4	
16A		00023108000	TUERCA AUTOBLOCANTE 8M125 DADO NUT	MUTTER ECROU	1 2 3 4	

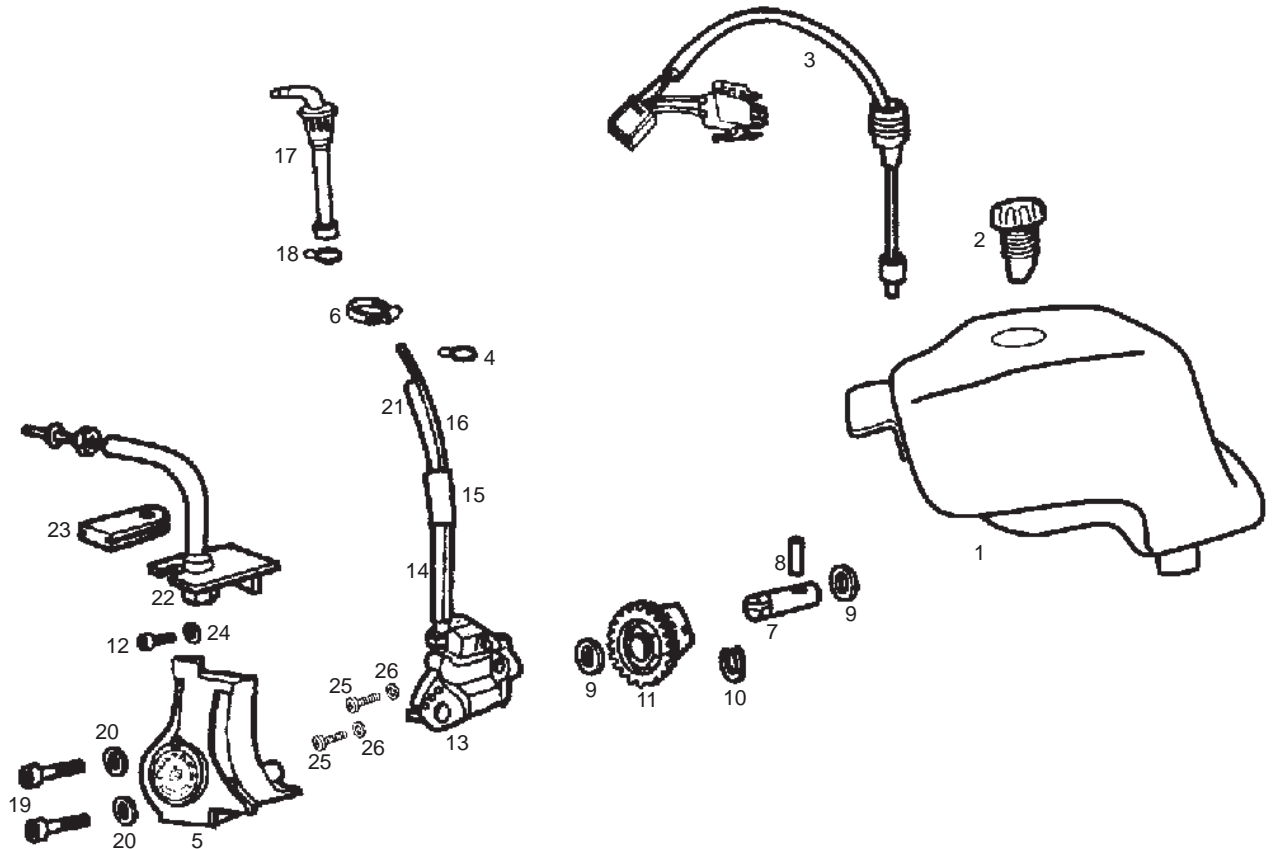

Fig.	Ver.	COD. KOD.	DESCRIPCIÓN DENOMINAZIONE NAME	BEZEICHNUNG DESIGNATION	MOD.	NOTAS NOTES NOTA MITSCHRIFT NOTES
01A		00H03704081	SCTO.DEPOSITO ACEITE. SUBSERBATOIO OLIO SE OIL, TANK	OILTANK RESERVOIR D,HUILLE	1 2 3 4	
02A		00F03710241	CTO.TAPON DEPTO.ACTE.SCO/90. TAPPO SERBATOIO OLIO OIL RESERVOIR FILLER PLUG ASSY	STOPFEN OELTANK ENS. BOUCHON RESERV.HUILLE S	1 2 3 4	
03A		00H03703051	CTO. INDICAD. NIVELACEITE TAPPO SERBATOIO OLIO OIL RESERVOIR FILLER PLUG ASSY	OLSTANDSGEBER NIVEAU D'HUILLE	1 2 3 4	
04A		00H03700211	BRIDA BRIGLIA BRIDLE	ZÜGEL BRIDE	1 2 3 4	
05A		00H03705011	TAPA BOMBA ACEITE COPERCHIO COVER	DECKEL COUVERCLE	1 2 3 4	
06A		00H00400501	ABRAZADERA ELASTICA FASCETTA CLAMP	KLAMMER CRAMPON	1 2 3 4	
07A		00H03700101	EJE BOMBA ACEITE. ASSE POMPA OLIO PUMPOILAXLE	OLPUMPUNACHSE AXE DE POMPE D,HUILLE	1 2 3 4	
08A		00053030000	PASADOR CHIAVISTELLO PIN	STIFT GOUDILLE	1 2 3 4	
09A		00H05000281	ARANDELA TOPE PIÑON INTERMD. RONDELLA WASHER	SCHEIBE RONDELLE	1 2 3 4	
10A		00000047110	ANILLO SEGURIDAD EJES D10 ANELLO SICUREZZA CIRCLIP	SICHERHEITSRING ANNEAU SECURITE	1 2 3 4	
11A		00H03800381	PIÑÓN BOMBAS AGUA/ACEITE 80 C.C. PIGNONE ACQUA/OLIO 80 C.C. PUMP OIL GEAR	ZAHNRAD PIGNON POMPE D,HUILLE	1 2 3 4	

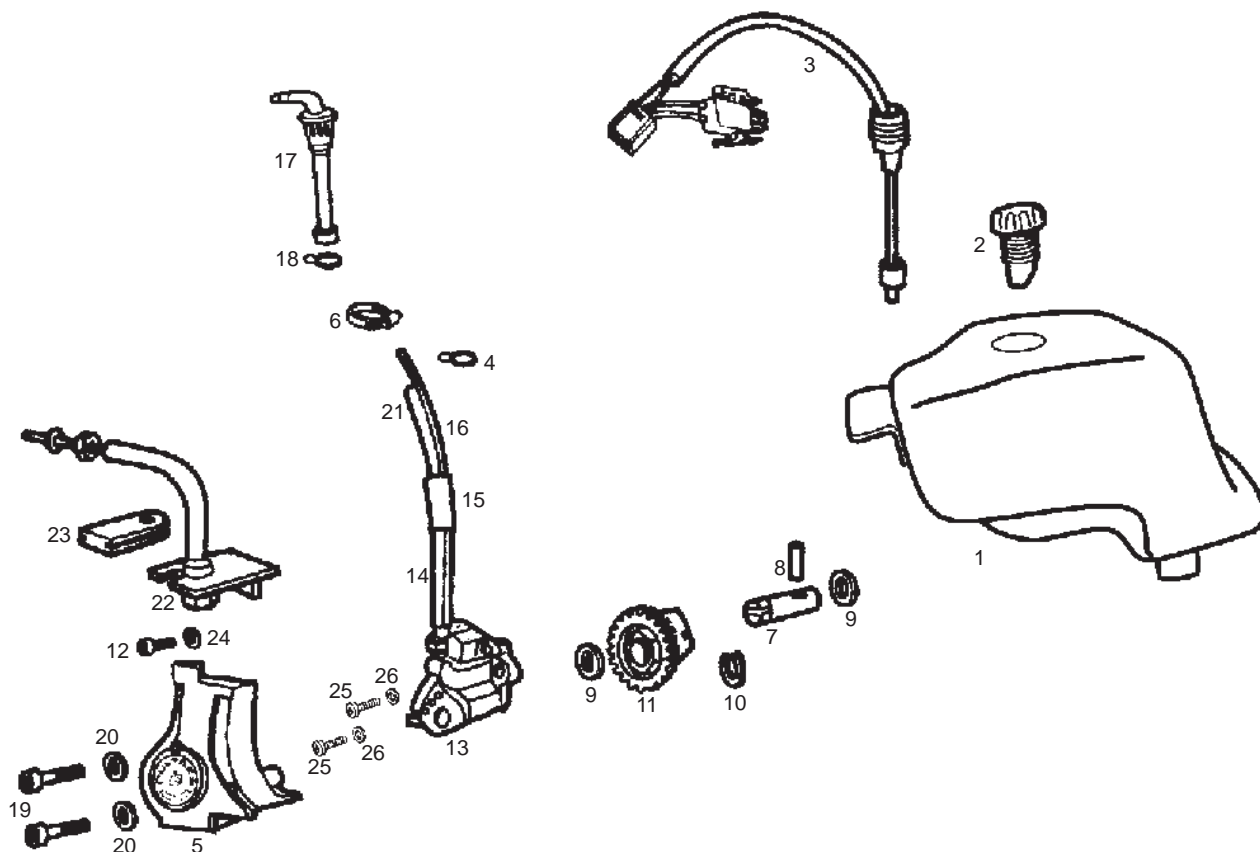

Fig.	Ver.	COD. KOD.	DESCRIPCIÓN DENOMINAZIONE NAME	BEZEICHNUNG DESIGNATION	MOD.	NOTAS NOTES NOTA MITSCHRIFT NOTES
12A		00000004510	TORNILLO C/ALLEN.5M80X10 VITE SCREW	SCHRAUBE VIS	1 2 3 4	
13A		00H03704021	CTO.BOMBA ACEITE. POMPA OLIO OIL PUMP	OLPUMPE POMPE A HUILLE	1 2 3 4	
14A		00F00406321	TUBO TUBO TUBE	ROHR TUYAU	1 2 3 4	
15A		00H03700351	MANGUITO UNION TUB.ACTE. MANICOTTO UNIONE TUBO OLIO OIL PIPE COUPLING CONNECTOR	VERBINDUNG MANCHON RACCORD TUYEAU DIHU	1 2 3 4	
16A		00H03702121	TUBO TUBO TUBE	ROHR TUYAU	1 2 3 4	
17A		00H03701411	CTO.FILTRO ACEITE. FILTRO OLIO BY-PAS OIL FILTER	FILTER FILTRE A HUILLE	1 2 3 4	
18A		00G00400501	ABRAZADERA ELASTICA FASCETTA CLAMP	KLAMMER CRAMPON	1 2 3 4	
19A		00002054551	TORNILLO C/ALLEN 5M80X45 VITE SCREW	SCHRAUBE VIS	1 2 3 4	
20A		00000033050	ARANDELA MUELLE D5 RONDELLA WASHER	SCHEIBE RONDELLE	1 2 3 4	
21A		00F00403321	TUBO SALIDA DPTO. ACEITE TUBO TUBE	ROHR TUYAU	1 2 3 4	
22A		00H03700311	SCTO.SOPTE.GUIA CABLES. SUBSOSTEGNO GUIDA CA OIL CABLE, SUPPORT	HALTER F. KABELFUHRUNG SOUS-ENS SUPPORT CABLE HUIL	1 2 3 4	

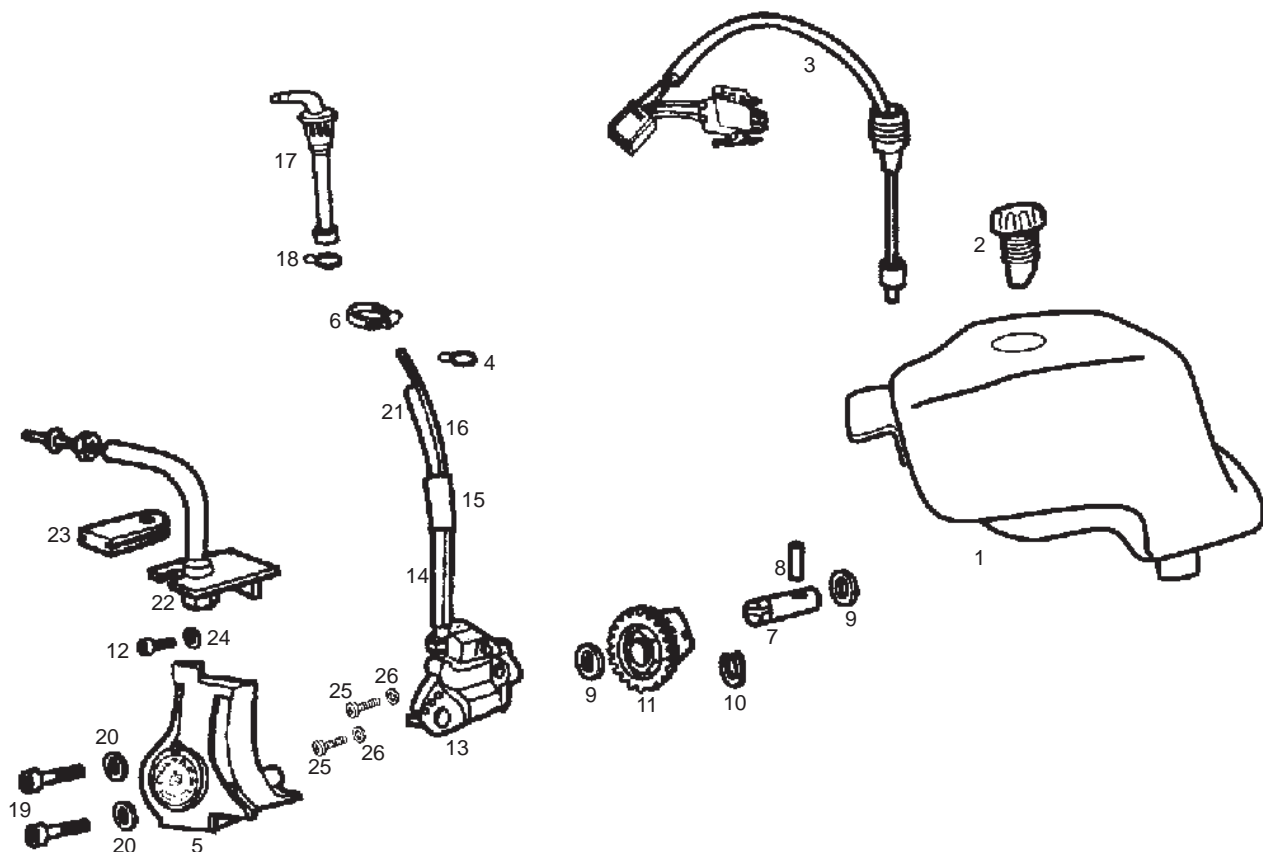

Fig.	Ver.	COD. KOD.	DESCRIPCIÓN DENOMINAZIONE NAME	BEZEICHNUNG DESIGNATION	MOD.	NOTAS NOTES NOTA MITSCHRIFT NOTES
23A		00H03700141	PASACABLE PORTACAVI GROMMET	GUMMI PASSE-CABLE	1 2 3 4	
24A		00000031050	ARANDELA PLANA MEC.D.5 RONDELLA WASHER	SCHEIBE RONDELLE	1 2 3 4	
25A		00002051551	TORNILLO C/ALLEN 5M80X15 VITE SCREW	SCHRAUBE VIS	1 2 3 4	
26A		00000033050	ARANDELA MUELLE. D5 RONDELLA WASHER	SCHEIBE RONDELLE	1 2 3 4	



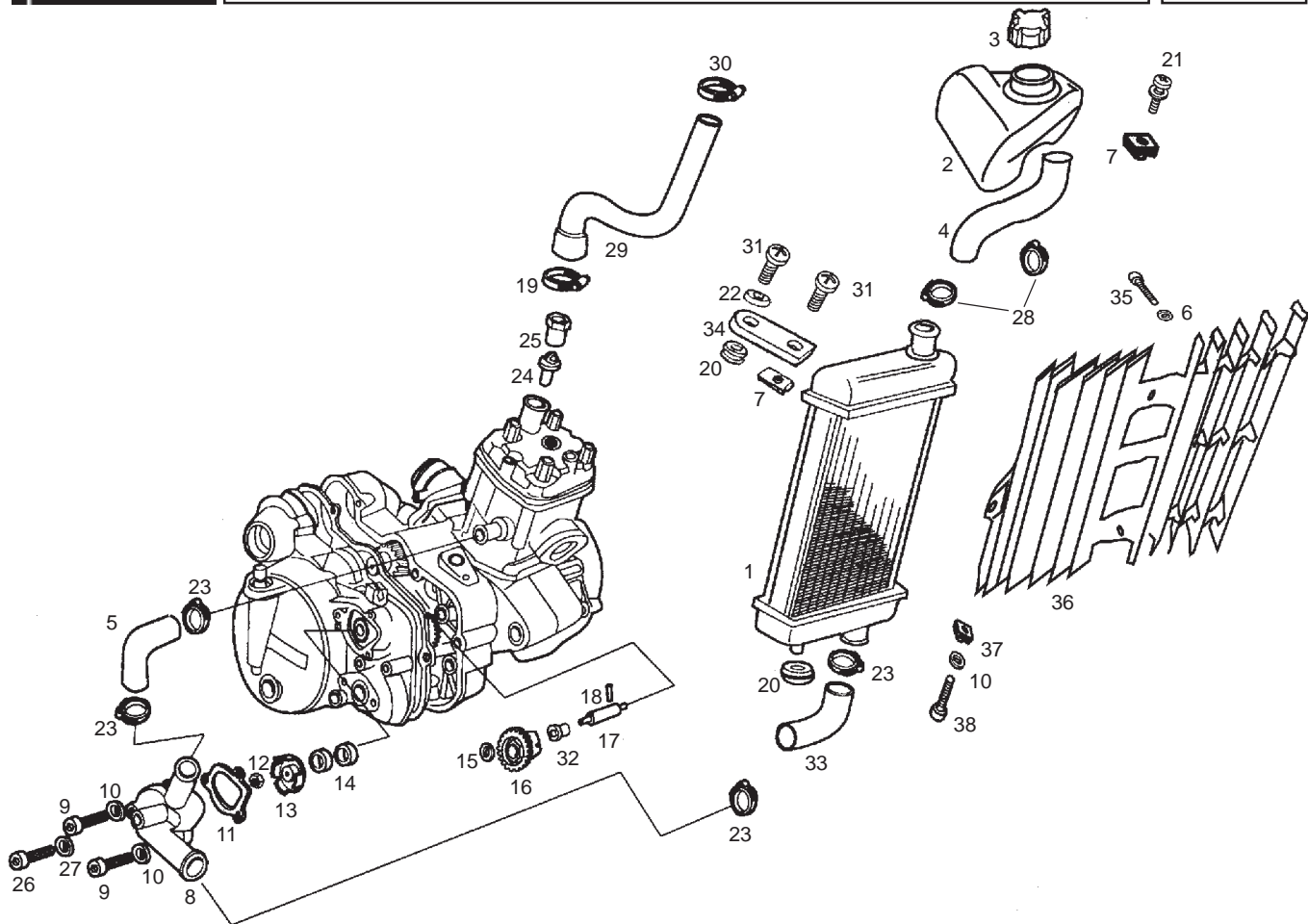

Fig.	Ver.	COD. KOD.	DESCRIPCIÓN DENOMINAZIONE NAME	BEZEICHNUNG DESIGNATION	MOD.	NOTAS NOTES NOTA MITSCHRIFT NOTES
01A		00H03805011	SCTO. RADIADOR SUBRADIATORE RADIATOR ASSY.	RADIATOR ASSY. RADIATEUR	1 2 3 4	
02A		00H03804501	DEPOSITO AGUA RADIADOR SERBATOIO ACQUA RADIATORE WATER TANK	WASSERBEHALTER VASE DI EXPANSION	1 2 3 4	
03A		00H03802472	CTO. TAPON RADIAD/DEP. AG. TAPPO RADIATORE/SERBATOIO WATER RESERVOIR/RAD CAP ASSY	KUEHLERDECKEL BOUCHON DE RESERVOIR D,EAU	1 2 3 4	
04A		00G03800601	TUBO REFRIG. BOMBA-RADIAD. TUBO TUBE	ROHR TUYAU	1 2 3 4	
05A		00H03801041	TUBO REFRIG. BOMBA-CILIND. TUBO TUBE	ROHR TUYAU	1 2 3 4	
06A		00D02600631	ARANDELA TOPE MUELLE EMBRAGUE RONDELLA WASHER	SCHEIBE RONDELLE	1 2 3 4	
07A		00D01501371	TUERCA FIJ. CUBRECADENA DADO NUT	MUTTER ECROU	1 2 3 4	
08A		00H03800134	TAPA BOMBA AGUA GRIS SARGA COPERCHIO COVER	DECKEL COUVERCLE	1 2 3 4	
09A		00002052051	TORNILLO C/ALLEN 5M80X15 VITE SCREW	SCHRAUBE VIS	1 2 3 4	
10A		00000031050	ARANDELA PLANA MEC.D.5 RONDELLA WASHER	SCHEIBE RONDELLE	1 2 3 4	
11A		00H03800141	JUNTA TAPA BOMBA AGUA. GUARNIZIONE GASKET	DICHTUNG JOINT	1 2 3 4	

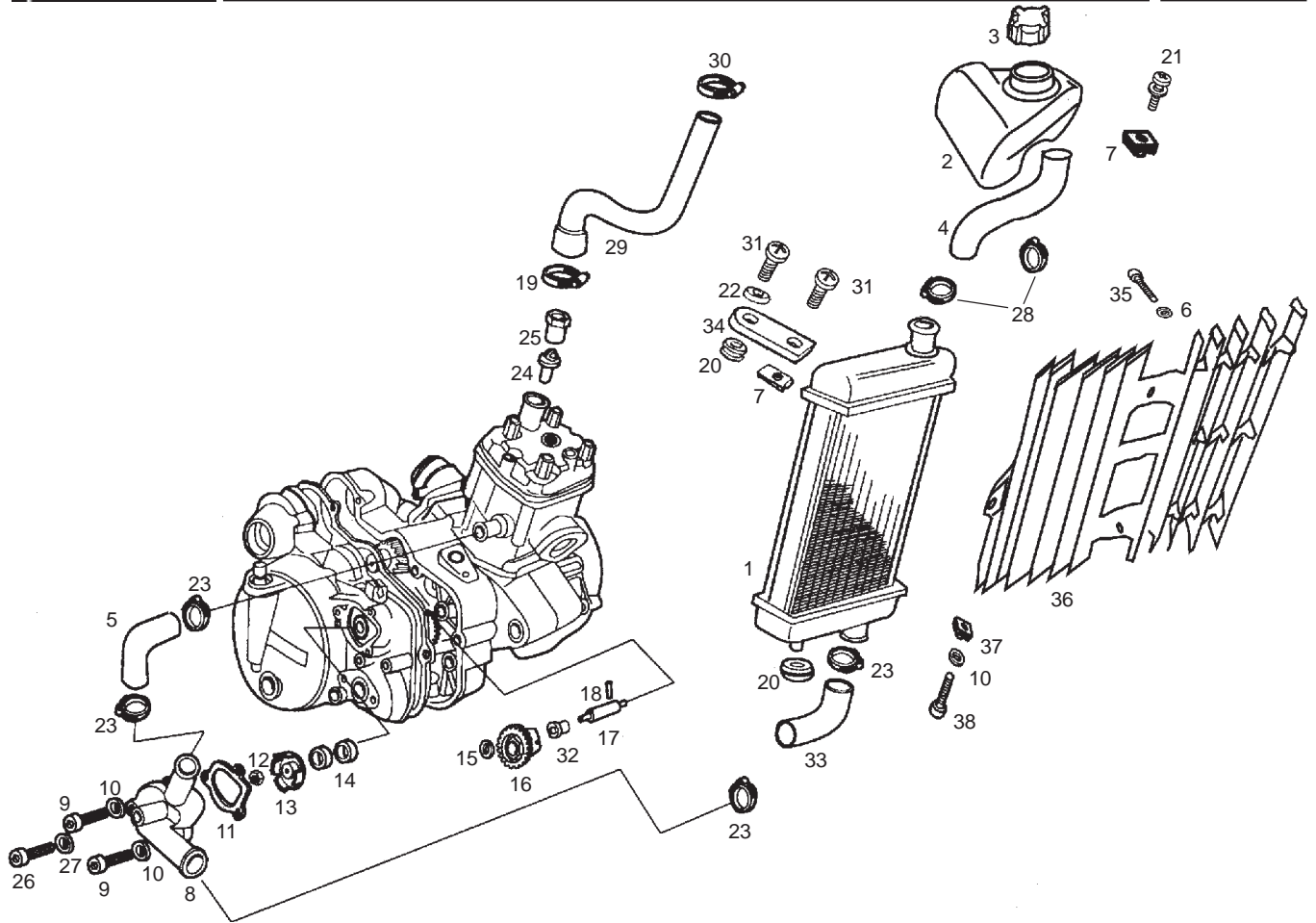

Fig.	Ver.	COD. KOD.	DESCRIPCIÓN DENOMINAZIONE NAME	BEZEICHUNG DESIGNATION	MOD.	NOTAS NOTES NOTA MITSCHRIFT NOTES
12A		00M03800221	TUERCA 5M80 DE LATON DADO NUT	MUTTER ECROU	1 2 3 4	
13A		00H03800151	RODETE BOMBA AGUA.80CC. ROCCHETTO POMPAACQUA 80CC WATER PUMP ROLLER	LAUFER F. WASSERPUMP CHIGNON POMPE D,EAU	1 2 3 4	
14A		00H03810211	RETEN EJE BOMBA AGUA 10X24X6 GIUNTO TENUTA SEAL	DICHTRING JOINT	1 2 3 4	
15A		00H05000281	ARANDELA TOPE PIÑON INTERMD. RONDELLA WASHER	SCHEIBE RONDELLE	1 2 3 4	
16A		00H03800381	PIÑON BOMBAS AGUA/ACEITE.80CC. PIGNONE POMPE ACQUA/OLIO 80CC PUMP OIL GEAR	ZAHNRAD PIGNON POMPE D,HUILLE	1 2 3 4	
17A		00H03800161	EJE BOMBA AGUA. ASSE POMPAACQUA WATER-PUMP SHAFT	WASSERPUMPENACHSE AXE POMPE D,AEU	1 2 3 4	
18A		00053030000	PASADOR CHIAVISTELLO PIN	STIFT GOUDILLE	1 2 3 4	
19A		00H03800451	ABRAZADERA FASCETTA CLAMP	KLAMMER CRAMPON	1 2 3 4	
20A		00008915020	PROTECCION CABLES. PROTEZIONE CAVI RUBBER,CABLE PROTECTOR	GUMMI PASSE-CABLE	1 2 3 4	
21A		00H05900021	SCTO. TORNILLO 6M100X16 VITE SCREW	SCHRAUBE VIS	1 2 3 4	
22A		00D01500552	CAZLTA.FIJ.SILENC. SCADELLINO FISSAGGIO HOUSING EXHAUST PIPE SUPPORT	ABDECKSCHEIBE CUVETTE	1 2 3 4	

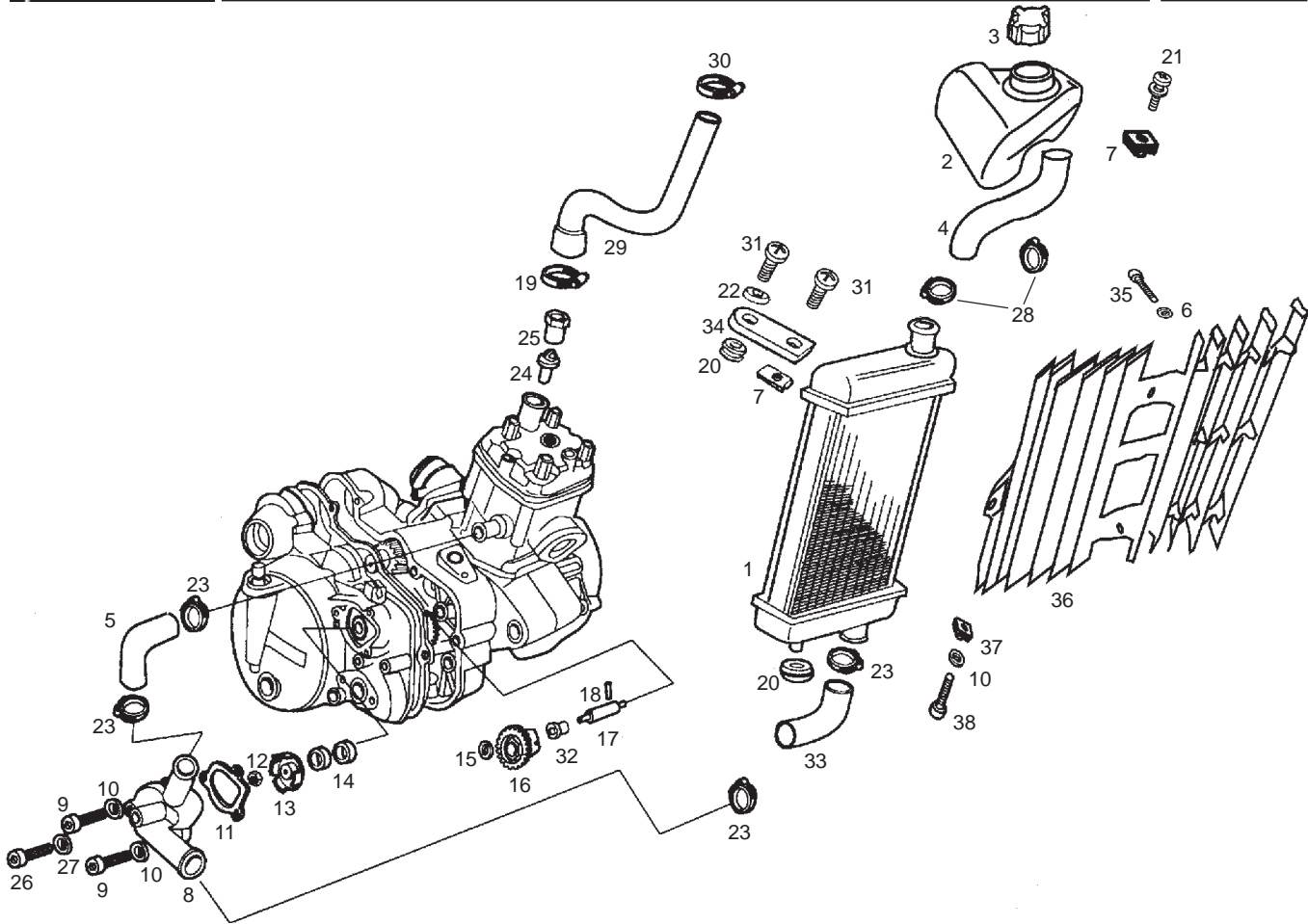

Fig.	Ver.	COD. KOD.	DESCRIPCIÓN DENOMINAZIONE NAME	BEZEICHNUNG DESIGNATION	MOD.	NOTAS NOTES NOTA MITSCHRIFT NOTES
23A		00H03800751	ABRAZADERA FASCETTA CLAMP	KLAMMER CRAMPON	1 2 3 4	
24A		483395	INTERRUPTOR TERMICO TERMOSTATO. THERMOSTATE.	THERMOSTAT THERMOSTAT	1 2 3 4	
25A		00H03810421	TUERCA FIJ. TERMOSTATO DADO NUT	MUTTER ECROU	1 2 3 4	
26A		00002051251	TORNILLO C/ALLEN 5M80X12 VITE SCREW	SCHRAUBE VIS	1 2 3 4	
27A		00H03800441	ARANDELA TOR. VACIADO AGUA RONDELLA WASHER	SCHEIBE RONDELLE	1 2 3 4	
28A		00G03801701	ABRAZADERA FASCETTA CLAMP	KLAMMER CRAMPON	1 2 3 4	
29A		00H03804021	TUBO CULATA-RADIADOR TUBO TUBE	ROHR TUYAU	1 2 3 4	
30A		00008204500	ABRAZADERA FASCETTA CLAMP	KLAMMER CRAMPON	1 2 3 4	
31A		00092061214	TORNILLO C/R.CR.6M100X12.NG VITE SCREW	SCHRAUBE VIS	1 2 3 4	
32A		00H03800231	CASQUILLO BRONZINA BUSHING	BUCHSE ENTRETOISE	1 2 3 4	
33A		00H03802031	TUBO REFRIG. BOMBA-RADIAD. TUBO TUBE	ROHR TUYAU	1 2 3 4	

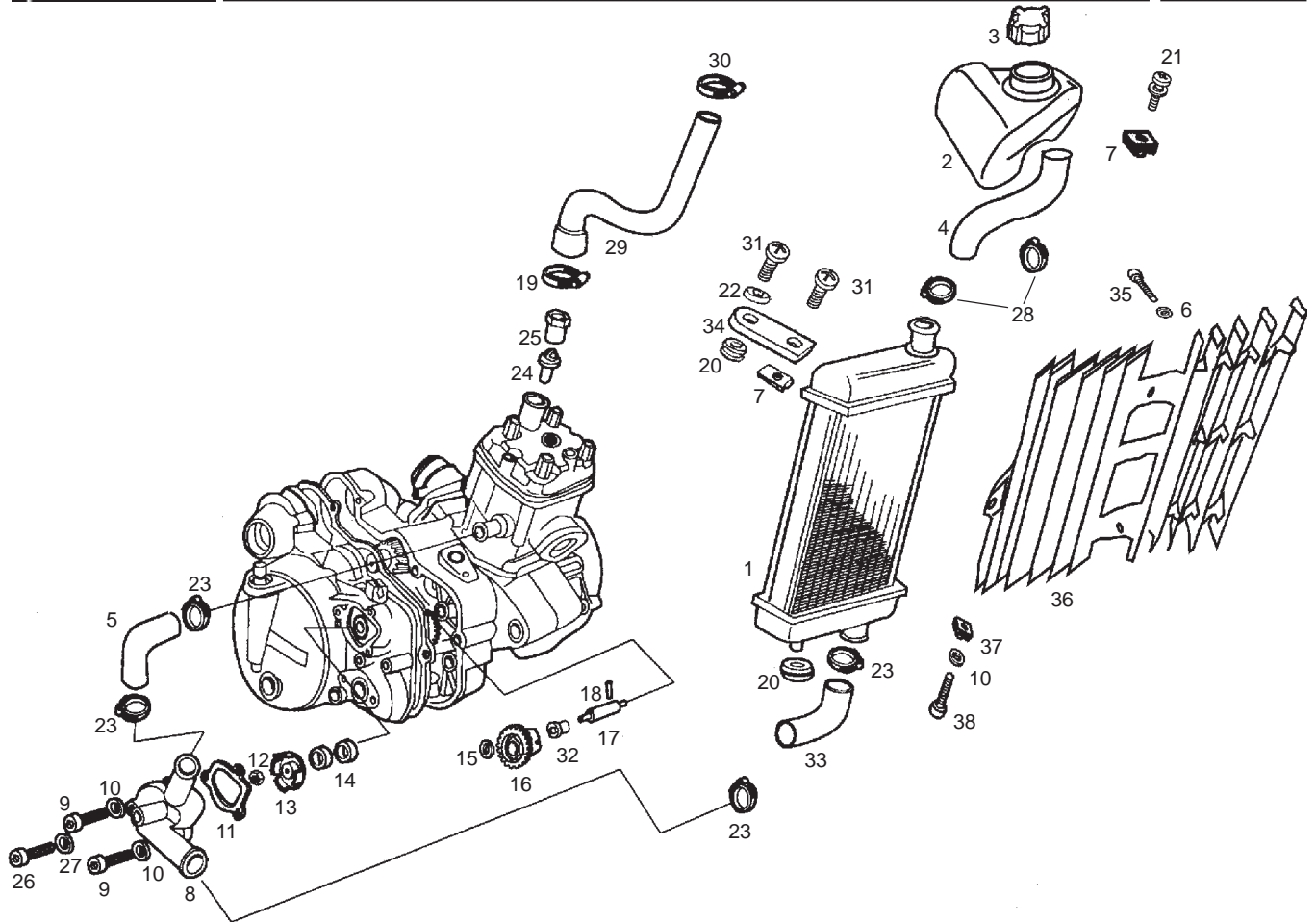

Fig.	Ver.	COD. KOD.	DESCRIPCIÓN DENOMINAZIONE NAME	BEZEICHNUNG DESIGNATION	MOD.	NOTAS NOTES NOTA MITSCHRIFT NOTES
34A		00G02200692	OREJA SUP. SOPT. RADIADOR PIASTRA SUPPORTO SUPERIORE UPPER RADIATOR SUPPORT	OESE KUEHLERBLOCK OREILLE SUPERIEURE SUPPORT RAD	1 2 3 4	
35A		00011141300	TORNILLO AUT.C/CR.NG.4,8X13 VITE SCREW	SCHRAUBE VIS	1 2 3 4	
36A		00H03805301	REJILLA RADIADOR GRIGLIA RADIATORE RADIATOR GRID	RADIATOR RADIATEUR	1 2 3 4	
37A		00G04401462	TUERCA FIJ. CUBRECADENA DADO NUT	MUTTER ECROU	1 2 3 4	
38A		00012151500	TORNILLO C/RED.ALL.5M100X16 VITE SCREW	SCHRAUBE VIS	1 2 3 4	

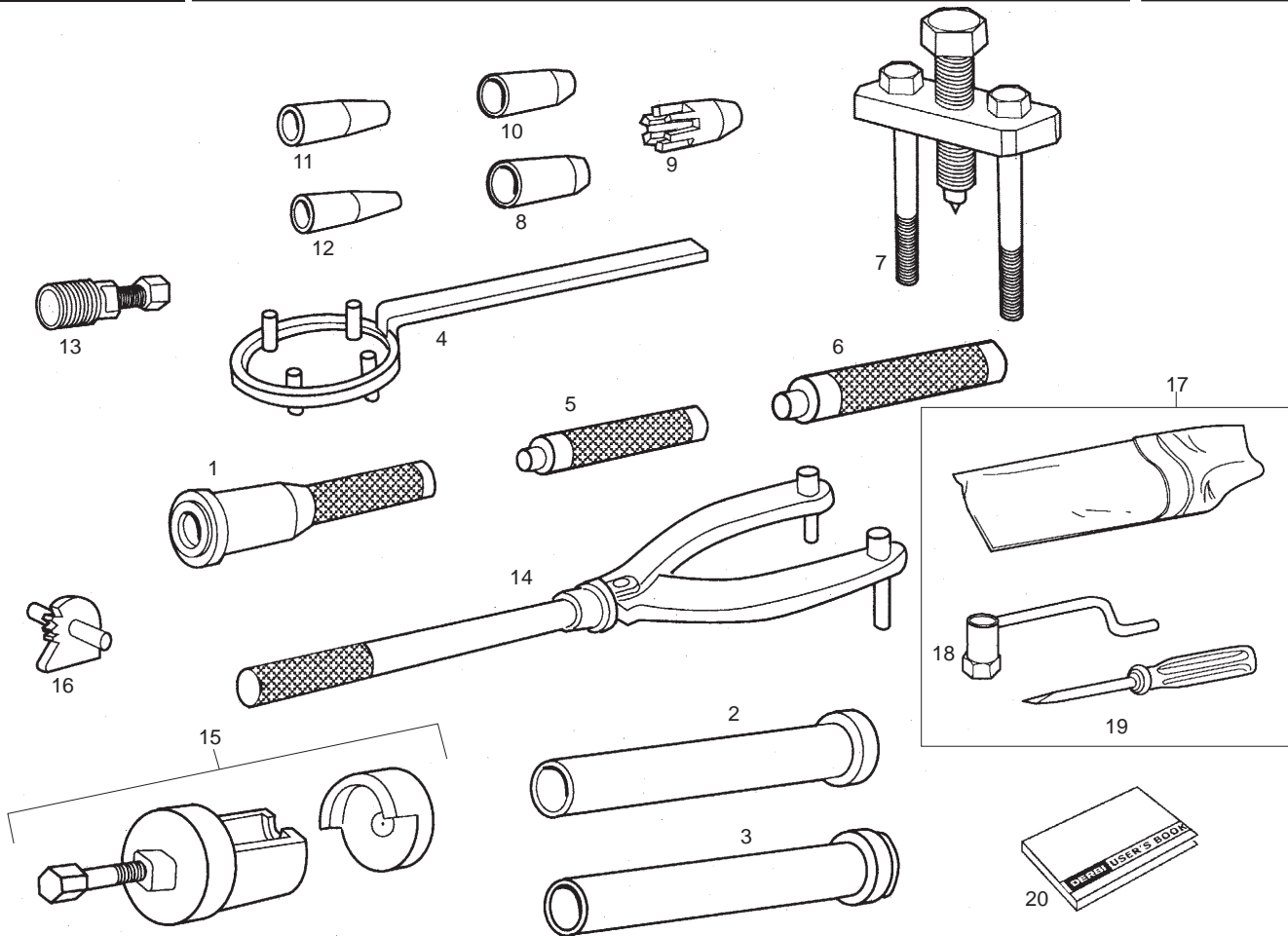

Fig.	Ver.	COD. KOD.	DESCRIPCIÓN DENOMINAZIONE NAME	BEZEICHNUNG DESIGNATION	MOD.	NOTAS NOTES NOTA MITSCHRIFT NOTES
01A		00H05400451	R-PUNZON MONT. RETENES CIGÜEÑAL R-PUNTERUOLO MONTAGGIO GIUNTI PUNCH FIXING CRANKCASE SEAL	DURCHSCHLAG OUTIL MONTAGE ANNEAU AXE VI	1 2 3 4	
02A		00H05400581	R-UTIL MONTAR RETEN EJE ARRQ. UTENSILE MONTAGGIO GIUNTI TENU TOOLS FOR FIXING IN STARTING	MONTAGEHUELSE OUTIL MONTAGE ANNEAU AXE DE	1 2 3 4	
03A		00H05401561	R-UTIL MONT. RETEN EJE SELECT. R-UTILE MONTAGGIO GIUNTO TENUT TOOL FOR FIXING SEAL IN SELEC	MONTAGEHULSE OUTIL MONTAGE ANNEAU AXE SE	1 2 3 4	
04A		00H05300041	R-CTO.UTIL. FIJ. CAMPNA EMBG. R-UTILE FISSAGGIO CA CLUTCH HOUSING HOLDER	BEF.-WKZG. KUPPLUNGSGLOCKE OUTIL FIXATION EMBRAYAGE	1 2 3 4	
05A		00H05600251	R-UTIL MONT. CASQ. AGUJ. PIÑ. INTM R-UTILE MONTAGGIO GHIERA FORO TOOLS FOR FIXING BUSHING NEEDL	MONTAGEHULSE OUTIL MONTAJE	1 2 3 4	
06A		00H05600241	R-UTIL MONT. CASQ. AGUJ. EJE 1P. R-UTILE MONTAGGIO GHIERA FORO TOOLS FOR FIXING BUSHING NEEDL	MONTAGEHULSE OUTILLAGE MONTAGE DOUILLE A	1 2 3 4	
07A		00H05300151	R-CTO.UTILABRIR MOTOR R-UTILE APRIRE MOTOR TOOLS OPEN ENGINE ASSY	WKZG. Z. MOTOR OFFNEN ENSEMBLE OUTILLAGE OUVRIR M	1 2 3 4	
08A		00H05300841	CASQUILLO R-UTILE APRIRE MOTOR TOOLS OPEN ENGINE ASSY	WKZG. Z. MOTOR OFFNEN ENSEMBLE OUTILLAGE OUVRIR M	1 2 3 4	
09A		00H05600351	PIVOTE GUIA RET. EJE SECUND. PERNO GUIDA GIUNTO TENUTAASSE PIVOT GUIDE SECONDARY AXEL,S	FUHRUNGZAPFEN PIVOT GUIDE JOINT AXE SECON	1 2 3 4	
10A		00H05600341	PIVOTE GUIA RET. EJE ARRQ. PERNO GUIDA GIUNTO TENUTAASSE PIVOT GUIDE STARTING AXEL,S SE	FUHRUNGZAPFEN PIVOT GUIDE JOINT AXE DEMAR	1 2 3 4	
11A		00H05600331	PIVOTE GUIA RET. EJE DESEMB. PERNO GUIDA GIUNTO TENUTAASSE PIVOT GUIDE SEAL OF CLUTCH REL	FUHRUNGZAPFEN PIVOT GUIDE JOINT AXE DEBRA	1 2 3 4	

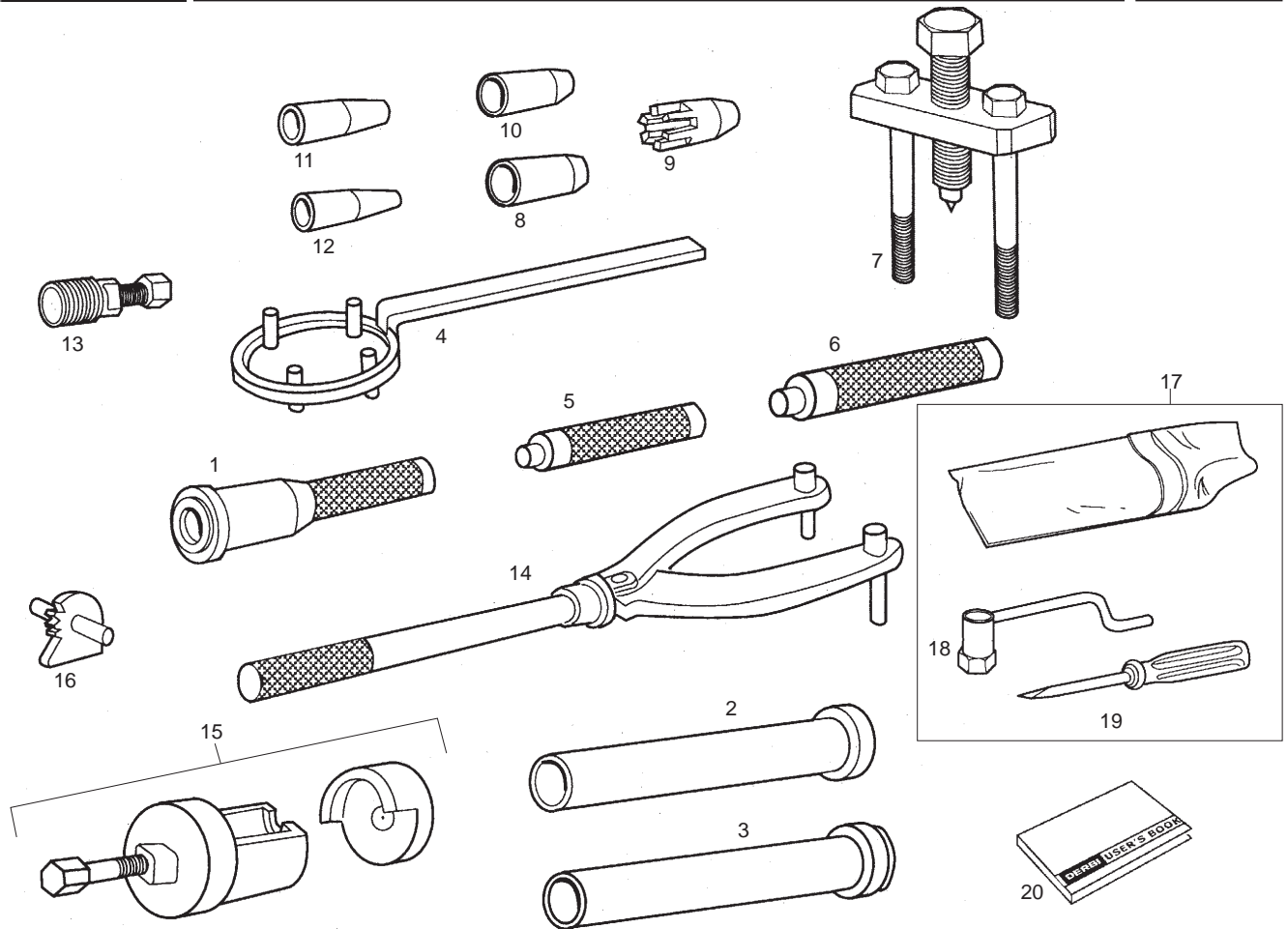

Fig.	Ver.	COD. KOD.	DESCRIPCIÓN DENOMINAZIONE NAME	BEZEICHNUNG DESIGNATION	MOD.	NOTAS NOTES NOTA MITSCHRIFT NOTES
12A		00H05600261	PIVOTE GUIA RET. EJE BOMBA AGUA PERNO GUIDA GIUNTO TENUTAASSE PIVOT GUIDE SEAL WATER PUMP	FUHRUNSZÄPFEN PIVOT GUIDE JOINT POMPE D,E	1 2 3 4	
13A		00F05300021	EXTRAC.VOLTE. ELECTR. DCT. SCO-50 ESTRATTORE VOLANO E FLYWHEEL ELECTR. EXTRACTOR	ABZIEHER EXTRACTEUR DE VOLANT	1 2 3 4	
14A		00G05300011	CTO. UTIL DESMTAR.VOLTE. ELECTR. CHIAVE VOLANO MAG./CAMPANA FR. MAGNETO EXTRACTOR TOOL	WERKZEUG Z. DEMONTAGE ELEKT ENS. OUTIL DEMONTER VOLANT E	1 2 3 4	
15A		00H05600321	CTO. EXTRACTOR ESTRATTORE PIGNONE COUNTERWEIGHT SPROKET PULLER	RITZELHALTER ESSEMBLE EXTRACTEUR PIGNON	1 2 3 4	
16A		00H05600231	R-SCTO. EJE PIÑON CONTRAPESO R-SUBASSE PIGNONE COUNTERWEIGHT SPROKET AXLE	BEF.-ACHSEF. RITZEL ENSEMBLE AXE PIGNON CONTREP	1 2 3 4	
17A		00H05101561	CTO. BOLSA HERRTAS. SACCO FERRI TOOL POUCH	WERKZEUGTASCHE TROUSSE A OUTILS	1 2 3 4	
18A		00H05100011	SCTO. LLAVE BUJIA AGUA SUBCHIAVE CANDELA SE SPARK PLUG	ZUND KERZENSCHLUSSEL CLE A BOUGIE	1 2 3 4	
19A		00005551290	DESTORNILLADOR CACCIAVITE SCREW DRIVER	SCHRAUBENZIEHER TOURNEVIS	1 2 3 4	
20A		00H05155121	MANUAL INSTRU. USUARIO LIBRETTI DI ISTRUZIONI USER'S BOOK	BEDIENUNGSANLEITUNG MANUEL D'INSTRUCTIONS	1 2 3 4	



CODIGO CODE	Lám. Diagnr.	Figr.	Vers.	CODIGO CODE	Lám. Diagnr.	Figr.	Vers.	CODIGO CODE	Lám. Diagnr.	Figr.	Vers.	CODIGO CODE	Lám. Diagnr.	Figr.	Vers.
00A00900531	06	21A		00F03300731	20	06A		00H00300672	08	18A		00H01201331	08	16A	
00A00900531	07	35A		00F03310741	20	04A		00H00300672	09	15A		00H01202271	08	02A	
00A00900531	19	21A		00F03710131	04	16A		00H00300891	03	31A		00H01203031	08	22A	
00A03000121	18	08A		00F03710241	22	02A		00H00301401	03	05A		00H01204714	08	03A	
00A03000132	18	27A		00F04201361	21	11A		00H00301701	03	26A		00H01206061	08	12A	
00A03001422	18	07A		00F04700121	08	20A		00H00301801	03	25A		00H01206101	08	10A	
00D00200761	02	05A		00F05300021	24	13A		00H00301831	03	30A		00H01208191	08	13A	
00D00900531	07	03A		00F05900041	05	10A		00H00301851	03	28A		00H01209083	08	06A	
00D01000701	06	24A		00F05900041	07	26A		00H00301861	03	29A		00H01214021	08	11A	
00D01100201	10	04A		00G00200112	02	06A		00H00301871	03	27A		00H01219111	08	09A	
00D01200171	03	14A		00G00400181	04	11A		00H00302621	03	39A		00H01301491	03	36A	
00D01200171	04	29A		00G00400501	04	10A		00H00303892	03	37A		00H01301721	09	20A	
00D01200171	04	34A		00G00400501	22	18A		00H00310331	03	38A		00H01301831	08	21A	
00D01200171	07	23A		00G01000911	07	02A		00H00325971	03	01A		00H01302052	09	08A	
00D01201091	08	07A		00G01401321	04	03A		00H00400501	22	06A		00H01303091	09	22A	
00D01300192	03	06A		00G01500951	21	13A		00H00404051	04	24A		00H01303201	09	02A	
00D01301401	09	14A		00G01503701	10	06A		00H00410011	04	09A		00H01303521	10	29A	
00D01500021	05	20A		00G02200692	23	34A		00H00415681	04	01A		00H01303731	09	21A	
00D01500021	11	05A		00G03000211	18	22A		00H00502901	05	30A		00H01304202	03	02A	
00D01500471	04	36A		00G03001091	18	23A		00H00527651	05	36A		00H01304811	03	15A	
00D01500471	07	22A		00G03002091	18	24A		00H00529641	05	37A		00H01306181	09	04A	
00D01500552	04	22A		00G03200061	19	09A		00H00554691	05	06A		00H01306824	09	16A	
00D01500552	23	22A		00G03200101	19	19A		00H00554701	05	07A		00H01308361	09	12A	
00D01501371	03	12A		00G03200511	19	11A		00H00604141	04	02A		00H01308531	09	09A	
00D01501371	04	28A		00G03200541	19	15A		00H00606021	04	18A		00H01309321	09	11A	
00D01501371	04	32A		00G03200551	19	16A		00H00611521	05	31A		00H01309352	09	13A	
00D01501371	05	08A		00G03200721	19	17A		00H00620161	05	14A		00H01331031	09	06A	
00D01501371	07	28A		00G03200731	19	18A		00H00625011	04	17A		00H01500421	03	33A	
00D01501371	19	27A		00G03201071	19	10A		00H00625012	04	17B		00H01500691	04	35A	
00D01501371	20	12A		00G03201091	19	24A		00H00705121	05	13A		00H01501212	09	18A	
00D01501371	23	07A		00G03201371	19	12A		00H00718341	05	11A		00H01501701	05	09A	
00D01520096	01	20A		00G03204272	04	13A		00H00721021	05	01A		00H01501811	05	27A	
00D01540456	01	21A		00G03301271	20	05A		00H00721023	05	01B		00H01501811	10	24A	
00D02600552	14	12A		00G03301401	20	02A		00H00800422	01	28A		00H01502201	09	17A	
00D02600631	07	17A		00G03800601	23	04A		00H00803082	01	10A		00H01502871	03	16A	
00D02600631	10	21A		00G03801701	23	28A		00H00805072	01	12A		00H01503741	07	15A	
00D02600631	11	03A		00G03900821	18	19A		00H00819011	01	09A		00H01508181	03	11A	
00D02600631	21	12A		00G04100771	19	23A		00H00900871	06	10A		00H01511191	03	24A	
00D02600631	23	06A		00G04102131	19	20A		00H00903291	06	16A		00H01533321	07	09A	
00D02820101	16	02A		00G04401462	05	24A		00H00906013	06	01A		00H01600911	11	04A	
00D02910131	17	04A		00G04401462	10	23A		00H00906203	06	06A		00H01615051	11	06A	
00D03210491	04	27A		00G04613921	06	28A		00H00907301	06	17A		00H01632521	11	01A	
00D03700131	04	12A		00G04700141	10	26A		00H00916171	06	03A		00H01636521	11	01B	
00D04000291	16	32A		00G05300011	24	14A		00H00919751	06	11A		00H01701011	07	40A	
00D05700141	07	11A		00G06800021	20	11A		00H00930071	06	15A		00H01704311	07	38A	
00D05900031	19	26A		00H00200701	02	18A		00H00930091	06	04A		00H01706021	07	39A	
00D05910081	21	08A		00H00201111	02	13A		00H01000131	07	10A		00H01800541	04	25A	
00E02500231	13	13A		00H00201441	02	20A		00H01001701	10	07A		00H01801771	01	15A	
00F00400131	04	07A		00H00201531	02	12A		00H01001911	07	02B		00H01802081	05	15A	
00F00400771	04	08A		00H00201581	02	21A		00H01005311	07	29A		00H01804331	03	08A	
00F00403321	04	14A		00H00201741	02	01A		00H01007841	07	25A		00H01810391	21	07A	
00F00403321	22	21A		00H00202101	02	26A		00H01009321	07	12A		00H01978601	01	01A	
00F00406321	22	14A		00H00202151	02	09A		00H01013011	07	06A		00H02008031	02	24A	
00F00900531	06	20A		00H00202201	02	16A		00H01038301	07	01A		00H02008041	02	25A	
00F00900531	07	34A		00H00202231	02	17A		00H01047301	07	01B		00H02100191	06	07A	
00F00900531	10	10A		00H00203261	02	15A		00H01100172	10	17A		00H02100861	06	08A	
00F00900531	20	10A		00H00203471	02	19A		00H01101731	10	05A		00H02100901	06	22A	
00F00920551	06	19A		00H00204191	02	14A		00H01102072	10	15A		00H02101011	06	18A	
00F01810411	01	29A		00H00204271	02	08A		00H01103211	10	08A		00H02101621	06	02A	
00F02201591	07	14A		00H00206171	02	10A		00H01103611	10	14A		00H02105082	06	05A	
00F02804371	16	22A		00H00208091	02	03A		00H01106181	10	12A		00H02105612	06	27A	
00F03200031	19	05A		00H00209011	02	07A		00H01110581	10	13A		00H02200591	05	25A	
00F03201211	19	02A		00H00220001	02	04A		00H01111081	10	01A		00H02200681	06	13A	
00F03300241	20	08A						00H01120021	10	16A		00H02201302	01	24A	



CODIGO CODE	Lám. Diagr.	Figr.	Vers.	CODIGO CODE	Lám. Diagr.	Figr.	Vers.	CODIGO CODE	Lám. Diagr.	Figr.	Vers.	CODIGO CODE	Lám. Diagr.	Figr.	Vers.
00H02201312	01	06A		00H02802861	16	31A		00H03800134	23	08A		00H05600341	24	10A	
00H02201521	03	19A		00H02803161	16	35A		00H03800141	23	11A		00H05600351	24	09A	
00H02201591	05	19A		00H02803291	16	01A		00H03800151	23	13A		00H05700101	07	13A	
00H02207671	06	29A		00H02807131	16	06A		00H03800161	23	17A		00H05700481	07	04A	
00H02239371	07	05A		00H02810181	16	18A		00H03800181	14	04A		00H05701061	07	33A	
00H02300961	07	36A		00H02810231	16	09A		00H03800231	23	32A		00H05900021	04	37A	
00H02303441	13	20A		00H02810411	16	21A		00H03800381	22	11A		00H05900021	05	02A	
00H02304381	06	14A		00H02810421	16	23A		00H03800381	23	16A		00H05900021	23	21A	
00H02304501	07	08A		00H02810561	16	16A		00H03800441	14	20A		00H05901781	14	16A	
00H02305381	06	14B		00H02810631	16	29A		00H03800441	23	27A		00H05908251	01	30A	
00H02401282	09	10A		00H02810741	16	30A		00H03800451	23	19A		00H06001151	19	25A	
00H02402282	08	19A		00H02820211	16	07A		00H03800751	23	23A		00H06102251	04	23A	
00H02411331	09	01A		00H02820561	16	17A		00H03801041	23	05A		00H06201061	04	15A	
00H02500041	13	08A		00H02820651	16	26A		00H03802031	23	33A		00H06303401	01	16A	
00H02500272	01	18A		00H02820661	16	37A		00H03802472	23	03A		00H06303752	04	05A	
00H02500301	13	11A		00H02900011	17	12A		00H03804021	23	29A		00H06500451	01	19A	
00H02500491	18	29A		00H02900041	17	10A		00H03804501	23	02A		00H06800471	03	34A	
00H02500811	18	28A		00H02900091	17	06A		00H03805011	23	01A		00H99927E303	12	01A	
00H02501131	13	05A		00H02900271	17	11A		00H03805301	23	36A		00K05110651	05	12A	
00H02501491	18	11A		00H02900281	17	07A		00H03810211	23	14A		00M03800221	23	12A	
00H02502111	13	03A		00H02900761	17	02A		00H03810421	23	25A		00000004510	16	24A	
00H02502121	13	04A		00H02901441	17	08A		00H04107181	19	06A		00000004510	22	12A	
00H02502891	18	10A		00H02901551	17	09A		00H04302181	04	06A		00000004625	02	22A	
00H02505021	13	07A		00H02902252	17	13A		00H04415771	05	04A		00000004835	02	02A	
00H02506141	13	09A		00H03000031	18	02A		00H04415772	05	04B		00000012415	21	10A	
00H02507061	18	20A		00H03000081	18	14A		00H04415781	05	05A		00000013510	16	05A	
00H02510641	18	21A		00H03000091	18	26A		00H04415782	05	05B		00000021040	05	18A	
00H02512013	13	06A		00H03000141	18	05A		00H04603841	07	20A		00000021060	03	21A	
00H02542091	13	02A		00H03000272	01	26A		00H04605841	07	19A		00000023051	05	26A	
00H02552091	13	02B		00H03003634	18	01A		00H04612091	05	34A		00000023060	05	29A	
00H02562091	13	02C		00H03005241	18	06A		00H04612101	05	35A		00000023060	07	24A	
00H02572091	13	02D		00H03007882	18	04A		00H04701171	10	25A		00000031040	05	17A	
00H02600111	14	03A		00H03010361	18	03A		00H04702121	10	02A		00000031050	03	10A	
00H02600151	14	07A		00H03201201	19	22A		00H04703141	08	14A		00000031050	05	21A	
00H02600181	14	13A		00H03201251	04	26A		00H04722082	08	01A		00000031050	22	24A	
00H02600211	14	14A		00H03202281	19	08A		00H04903292	01	22A		00000031050	23	10A	
00H02600271	14	09A		00H03203481	19	07A		00H04926561	05	32A		00000031060	02	23A	
00H02600322	14	22A		00H03203711	19	14A		00H04926562	05	32B		00000031070	03	22A	
00H02600342	14	19A		00H03204231	19	13A		00H04926571	05	33A		00000033050	22	20A	
00H02600401	14	26A		00H03204421	19	04A		00H04926572	05	33B		00000033050	22	26A	
00H02600551	14	10A		00H03207261	04	33A		00H05000281	14	15A		00000034050	16	25A	
00H02600651	14	25A		00H03214431	19	03A		00H05000281	22	09A		00000036100	17	17A	
00H02601011	14	11A		00H03243011	19	01A		00H05000281	23	15A		00000047110	14	17A	
00H02601161	14	08A		00H03300221	20	07A		00H05001011	13	16A		00000047110	22	10A	
00H02601381	14	02A		00H03301211	20	14A		00H05001551	13	18A		00000047111	17	03A	
00H02610311	14	18A		00H03311011	20	01A		00H05007123	13	01A		00000047122	17	14A	
00H02700151	15	01A		00H03330171	20	03A		00H05100011	24	18A		00000056202	08	05A	
00H02700231	15	03A		00H03404321	21	09A		00H05101561	24	17A		00000056202	09	05A	
00H02700251	15	09A		00H03431411	21	02A		00H05155121	24	20A		00000056205	01	14A	
00H02700441	15	04A		00H03450081	21	01A		00H05160651	05	39A		00000061040	17	18A	
00H02700451	15	05A		00H03603521	14	01A		00H05160652	05	39B		00000066060	16	33A	
00H02700491	15	06A		00H03700101	22	07A		00H05205481	12	02A		00000326260	14	06A	
00H02703421	15	10A		00H03700131	10	09A		00H05300041	24	04A		00001130370	18	15A	
00H02800181	16	11A		00H03700141	22	23A		00H05300151	24	07A		00001213190	03	18A	
00H02800241	16	34A		00H03700211	22	04A		00H05300841	24	08A		00002025190	13	10A	
00H02800251	16	13A		00H03700311	22	22A		00H05400451	24	01A		00002026020	14	24A	
00H02800401	16	19A		00H03700351	22	15A		00H05400581	24	02A		00002027280	14	21A	
00H02800561	16	15A		00H03700461	18	18A		00H05401561	24	03A		00002027280	15	07A	
00H02800801	16	28A		00H03701411	22	17A		00H05600231	24	16A		00002028450	16	12A	
00H02800881	16	27A		00H03702121	22	16A		00H05600241	24	06A		00002028550	16	14A	
00H02800891	16	36A		00H03703051	22	03A		00H05600251	24	05A		00002028770	15	08A	
00H02800901	16	04A		00H03704021	22	13A		00H05600261	24	12A		00002028770	17	01A	
00H02801221	16	08A		00H03704081	22	01A		00H05600321	24	15A		00002029050	17	15A	
00H02801481	16	10A		00H03705011	22	05A		00H05600331	24	11A		00002030020	18	09A	

CODIGO CODE	Lám. Diagr.	Figr.	Vers.	CODIGO CODE	Lám. Diagr.	Figr.	Vers.	CODIGO CODE	Lám. Diagr.	Figr.	Vers.	CODIGO CODE	Lám. Diagr.	Figr.	Vers.
00002051251	06	23A		00012151500	10	22A									
00002051251	23	26A		00012151500	23	38A									
00002051551	22	25A		00012152000	05	23A									
00002052051	23	09A		00012152000	11	02A									
00002054551	22	19A		00012161600	04	30A									
00002061011	18	12A		00014041200	06	09A									
00002062011	21	03A		00022084021	01	04A									
00002062511	05	28A		00022084521	01	07A									
00002062511	15	11A		00023108000	01	05A									
00002082021	02	11A		00023108000	01	13A									
00002083001	08	15A		00023108000	10	20A									
00002083001	10	28A		00023108000	21	16A									
00002125170	13	17A		00023108000	21	06A									
00002182000	09	07A		00023112000	03	32A									
00002212070	08	08A		00026005000	07	18A									
00002212070	09	19A		00031105000	05	38A									
00002215152	01	25A		00031106000	07	42A									
00002225220	13	14A		00031120123	03	35A									
00002503230	03	04A		00032015000	08	04A									
00002518790	01	17A		00032015000	09	03A									
00003102280	18	13A		00034000802	08	17A									
00003112322	03	03A		00034000802	10	27A									
00003115422	03	23A		00036008000	01	02A									
00003125280	13	19A		00037000600	17	21A									
00003127200	17	19A		00047030400	04	04A									
00003130050	18	16A		00047030900	17	16A									
00003133230	20	09A		00047031100	15	02A									
00003133260	20	13A		00052062011	14	23A									
00003710110	07	31A		00053030000	22	08A									
00003710120	07	32A		00053030000	23	18A									
00004162500	17	20A		00057120300	16	03A									
00005010760	06	25A		00058020301	16	20A									
00005527540	10	19A		00059220400	13	12A									
00005529290	17	05A		00073481964	04	31A									
00005530600	18	17A		00092061214	23	31A									
00005551290	24	19A		00262080022	01	08A									
00006309260	06	26A		00262100032	01	27A									
00006321040	06	12A		00262120032	03	07A									
00006321040	10	03A		00402060001	05	16A									
00006826230	14	05A		00402080001	01	03A									
00008061500	07	27A		00402080001	10	18A									
00008063000	07	41A		00402080001	21	15A									
00008202730	13	15A		00402080001	21	05A									
00008204500	23	30A		00402100001	01	23A									
00008902630	01	11A		00442060002	15	12A									
00008915020	04	21A		483395	23	24A									
00008915020	07	21A		828152	18	25A									
00008915020	23	20A													
00011041300	10	11A													
00011051401	04	19A													
00011051401	05	22A													
00011061300	07	37A													
00011141300	03	09A													
00011141300	23	35A													
00012045000	07	07A													
00012051200	07	16A													
00012061000	03	17A													
00012061200	03	13A													
00012061200	04	20A													
00012061200	05	03A													
00012061200	07	30A													
00012063000	03	20A													
00012081621	21	04A													
00012081621	21	14A													